

NOTE: 50% TIGHTEN BEFORE FIXING ALL BOLTS

A

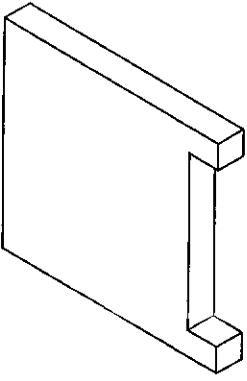

X3

B

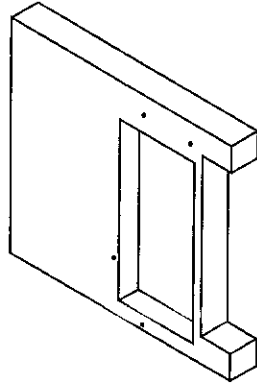

X3

C

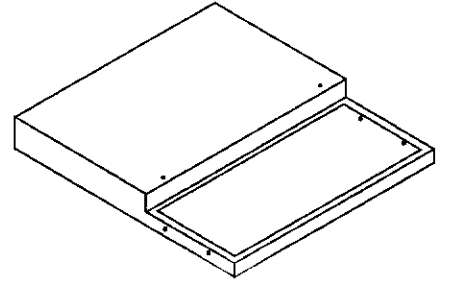

X2

D

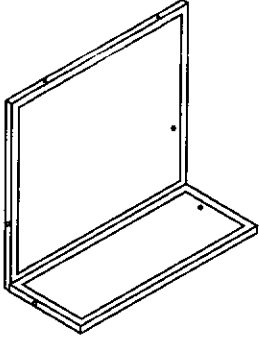

X2

E

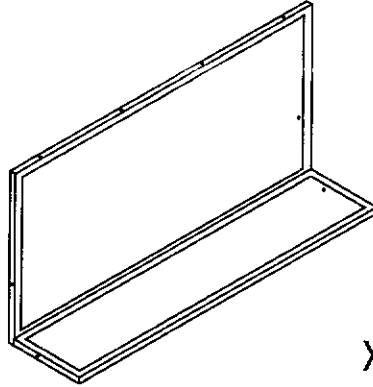

X1

F

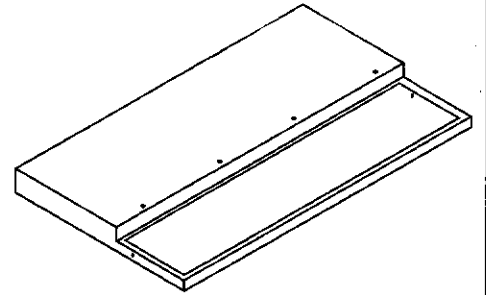

X1

G

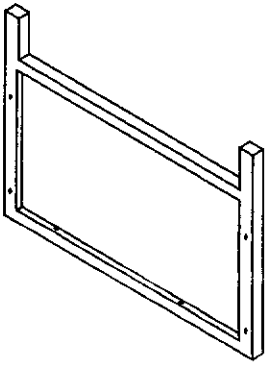

X2

H

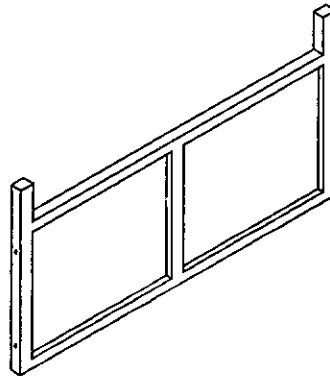

X2

I

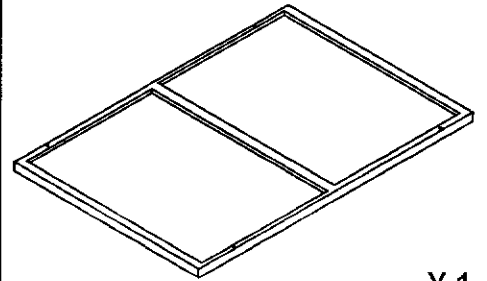

X1

J

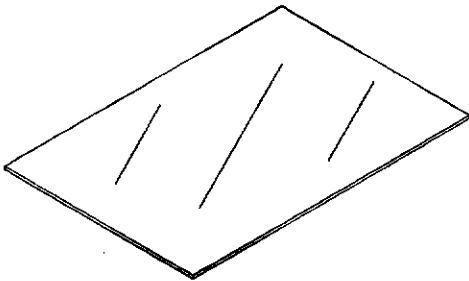

X1

K



M 6X35

X44

L

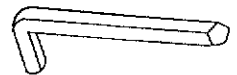

X1

1

NOTE: 50% TIGHTEN BEFORE FIXING ALL BOLTS

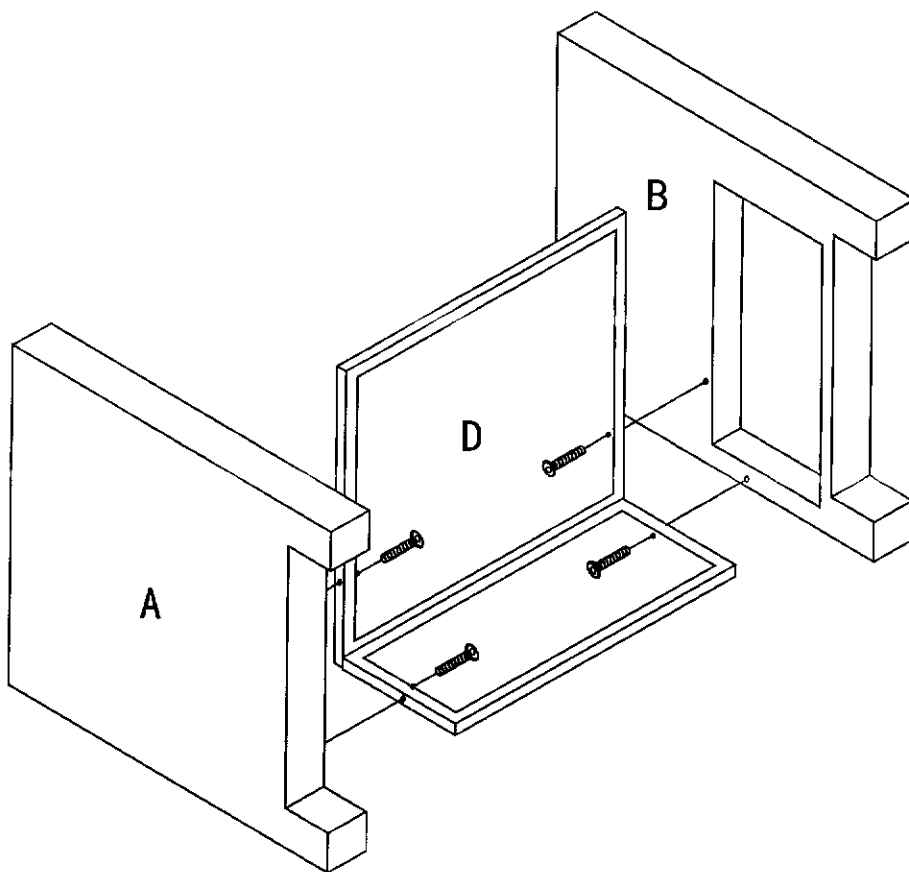

2

NOTE: 50% TIGHTEN BEFORE FIXING ALL BOLTS

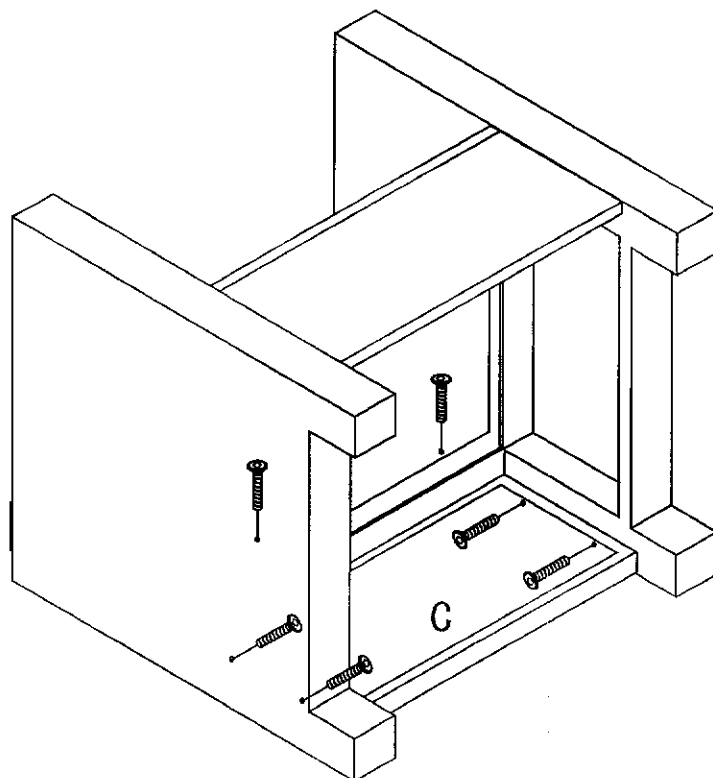

3

NOTE: 50% TIGHTEN BEFORE FIXING ALL BOLTS

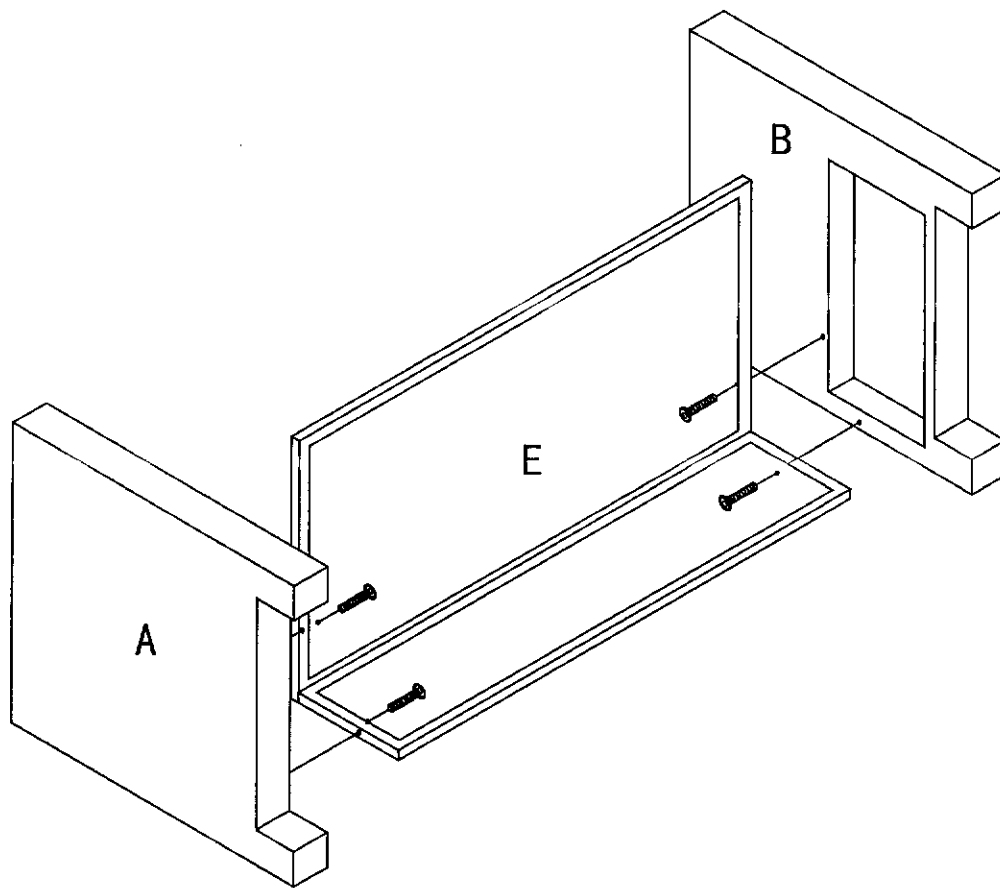

4

NOTE: 50% TIGHTEN BEFORE FIXING ALL BOLTS

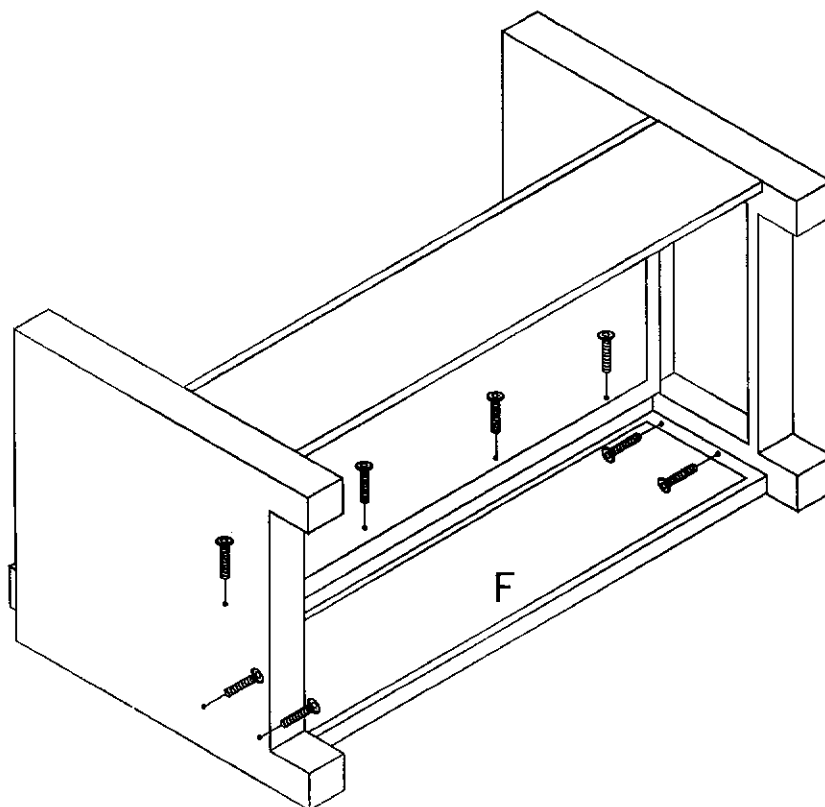

5

NOTE: 50% TIGHTEN BEFORE FIXING ALL BOLTS

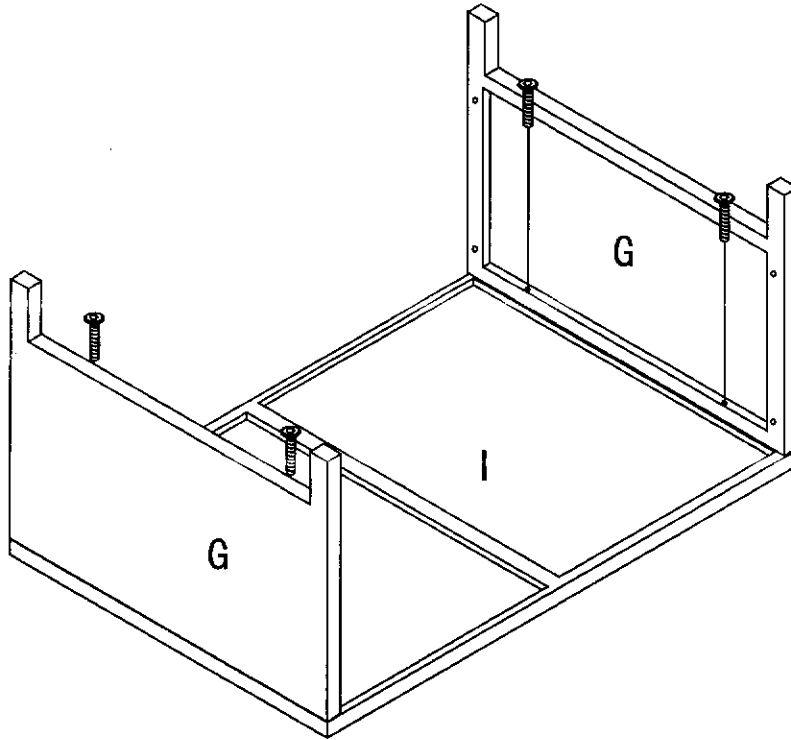

6

NOTE: 50% TIGHTEN BEFORE FIXING ALL BOLTS

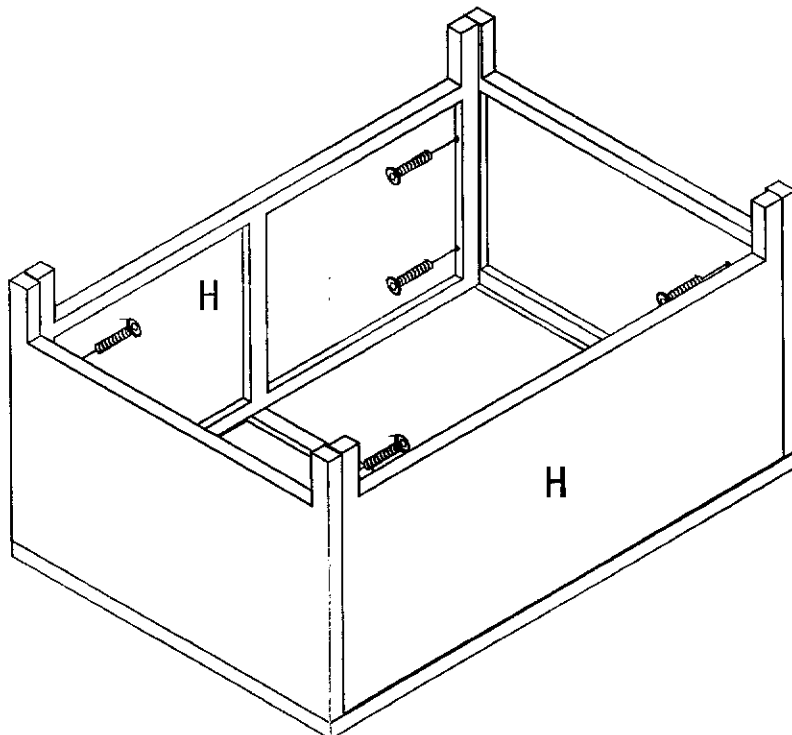

7

NOTE:50% TIGHTEN BEFORE FIXING ALL BOLTS

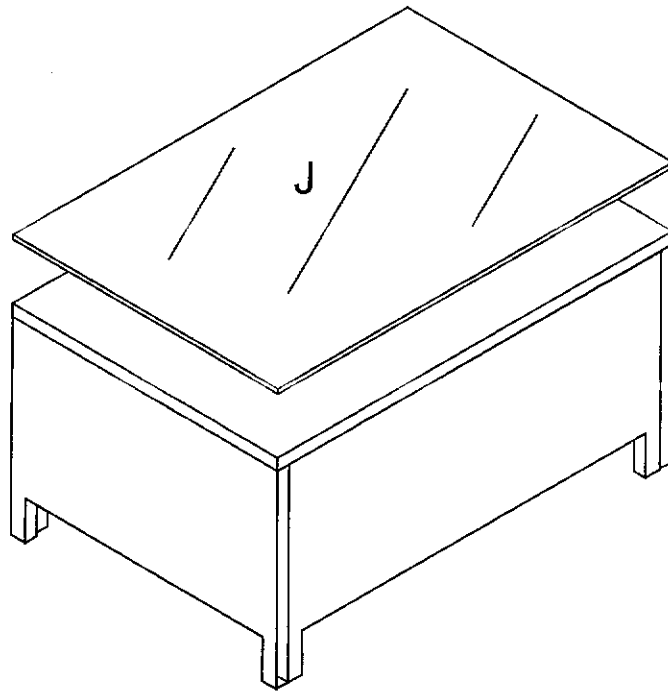

8

NOTE:50% TIGHTEN BEFORE FIXING ALL BOLTS

