

8

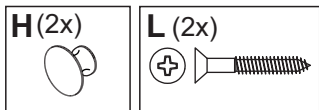

PESO MÁXIMO SUPORTADO
MAXIMUM WEIGHT SUPPORTED
PESO MAXIMO SOPORTADO

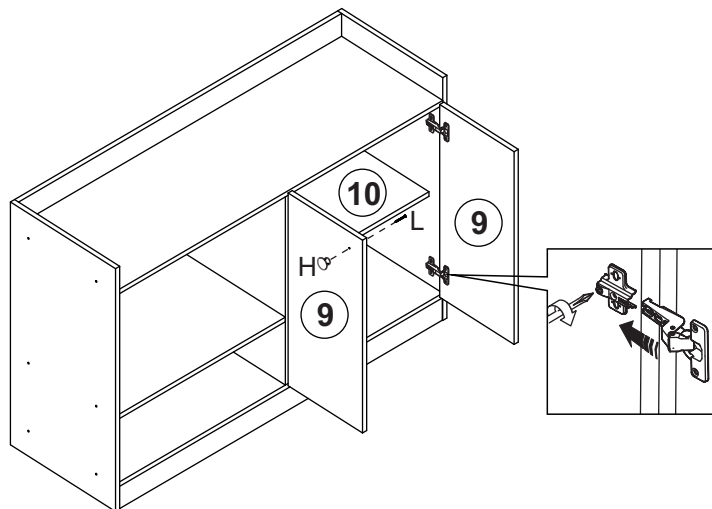
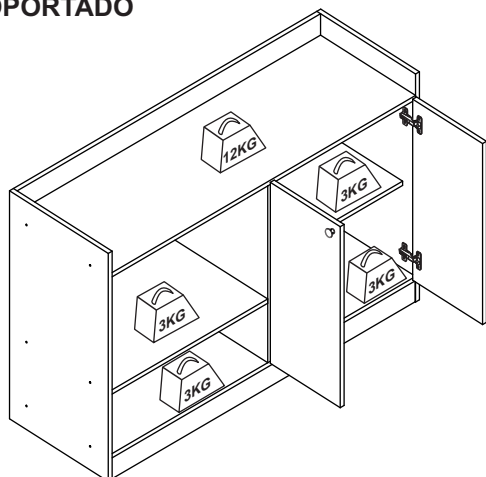

Manutenção e Limpeza:

Use pano levemente umedecido com água, seguido de pano seco. Nunca utilize produtos químicos ou abrasivos.

Maintenance and Cleaning:

Use a cloth slightly dampened with water, followed by a dry cloth. Never use chemicals or abrasives.

Mantenimiento y limpieza:

Use un paño ligeramente humedecido con agua, seguido de un paño seco. Nunca use productos químicos o abrasivos.

emovell

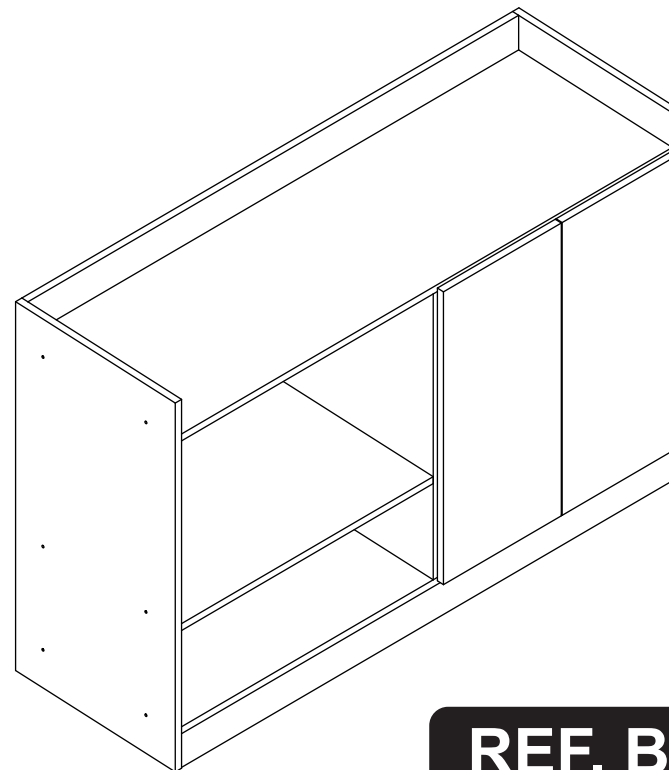

REF. B06



60 min.



Nova Móbile Ind. e Comércio Ltda.

Rua José Benediti, nº 1620 - Fone: +55 (054) 2105-8400 - +55 (054) 99614-6360
 CEP: 95706-500 - Bento Gonçalves - RS - Site: www.emovell.com.br - E-mail: comercial@emovell.com.br

Rev. 00 - 17/08/2022

FERRAGENS / HARDWARE LIST / LISTA DE HERRAJES



ATENÇÃO!!!









Em caso de uso de parafusadeira comece com um torque bem leve e vá aumentando até achar o ideal. Aperte somente até travar. Torque excessivo pode espanar o parafuso e danificar a peça comprometendo sua correta fixação.

ATTENTION!!!

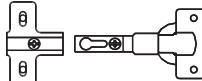
If using a screwdriver, start with a very light torque and increase until you find the ideal. Press only until it locks. Excessive torque can strip the bolt and damage the part, compromising its correct fixation.

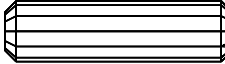
ATENCIÓN!!!

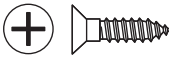
En caso de utilizar un destornillador, comience con un torque muy ligero y vaya aumentando hasta encontrar el ideal. Presione solo hasta que se detener. Torsión excesivo puede desempolvar el tornillo y dañar la pieza, comprometiendo su correcta fijación.

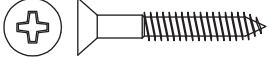
LOC.	IMAGEM / IMAGE / IMAGEN	QUANTIDADE # OF PIECES CANTIDAD
A	 3,5 x 35mm	02
B	 Suporte prateleira/Shelf support/ Soporte repisa	04
C	 8 x 8	20
D	 Dobradiça com calço Hinge with shim Bisagra con base	04
E	 Cantoneira/Mettalic angle/Pieza L	02
F	 Sapata/Shoe/Zapata	04
G	 8x30mm	28
H	 Puxador/Handle/Tirador	02
I	 4,0 x 40mm	14
J	 3,5 x 14mm	24
K	 Tapa furo/Cover hole/Tapa agujero	14
L	 4,0 x 25mm	02

6

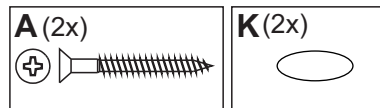
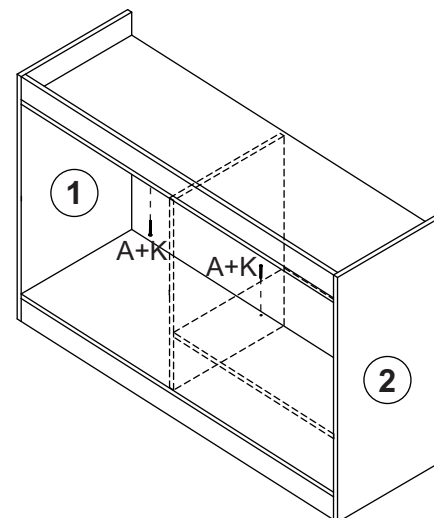

7

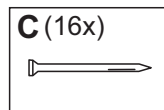
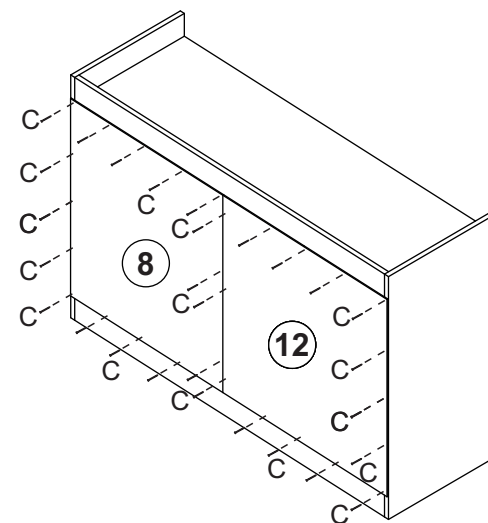

4

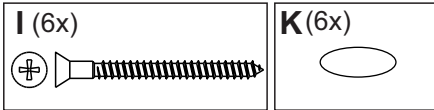
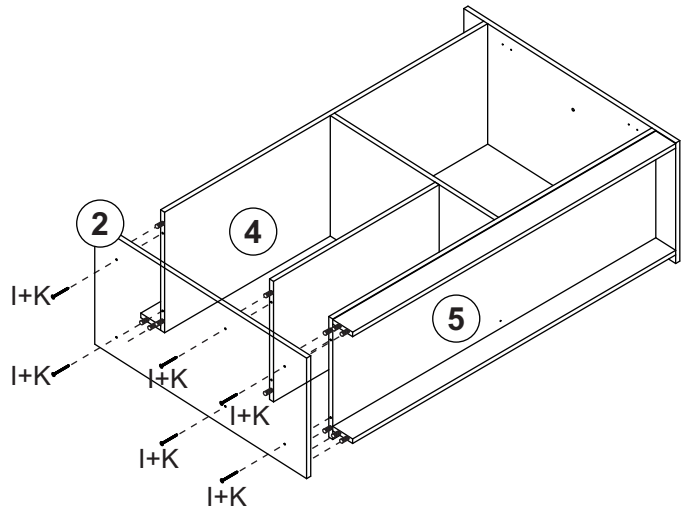

5

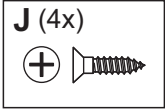
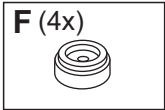
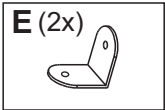
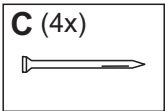
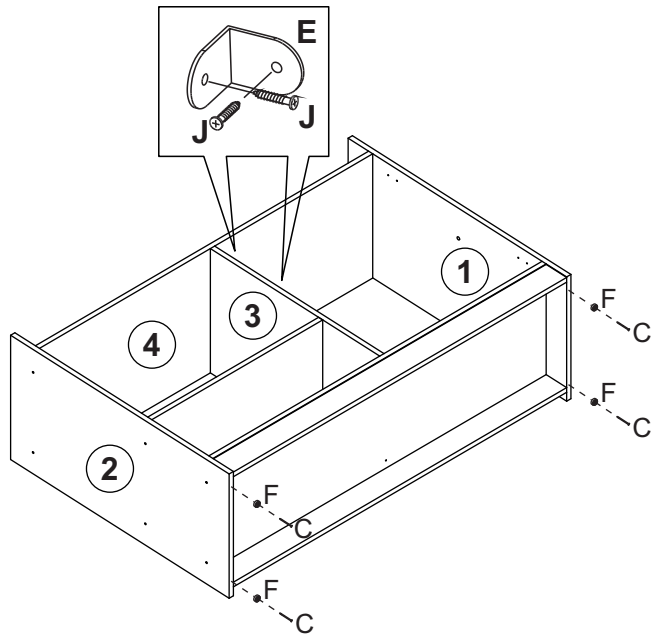

PARTES DO PRODUTO / PRODUCT PARTS / PARTES DEL PRODUCTO

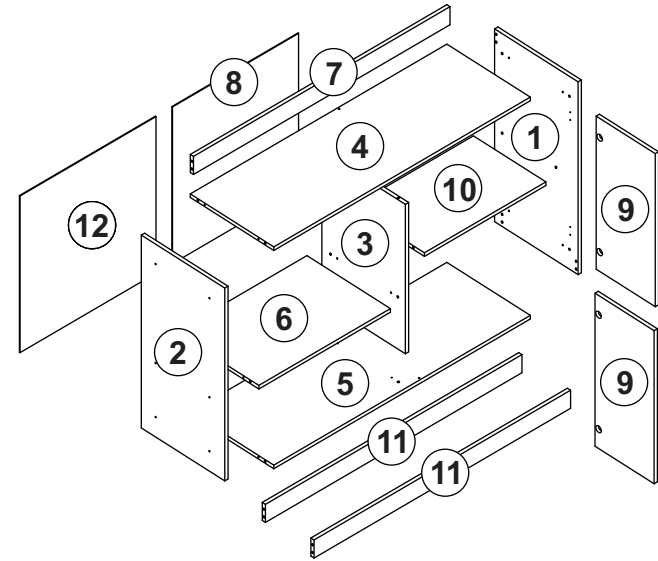

Loc.	Descrição / Description / Denominación	mm	Quantidade # Of Pieces Cantidad
1	Lateral direita/Right side/Lateral derecha	800x397x15	01
2	Lateral esquerda/Left side/Lateral izquierda	800x397x15	01
3	Divisão/Division/Divisória	620x397x15	01
4	Tampo/Top/Tapa	1170x397x15	01
5	Base inferior/Lower base/Base inferior	1170x397x15	01
6	Base intermediária/Intermediary base/Base del medio	600x397x15	01
7	Rodatampo/Top detail/Detalle tapa	1170x75x15	01
8	Costa menor/Small back/Revés menor	650x575x03	01
9	Porta/Door/Puerta	635x281x15	02
10	Prateleira/Shelf/Repisa	554x345x15	01
11	Rodapé/Baseboard/Zócalo	1170x75x15	02
12	Costa maior/Large back/Revés mayor	650x620x03	01

1

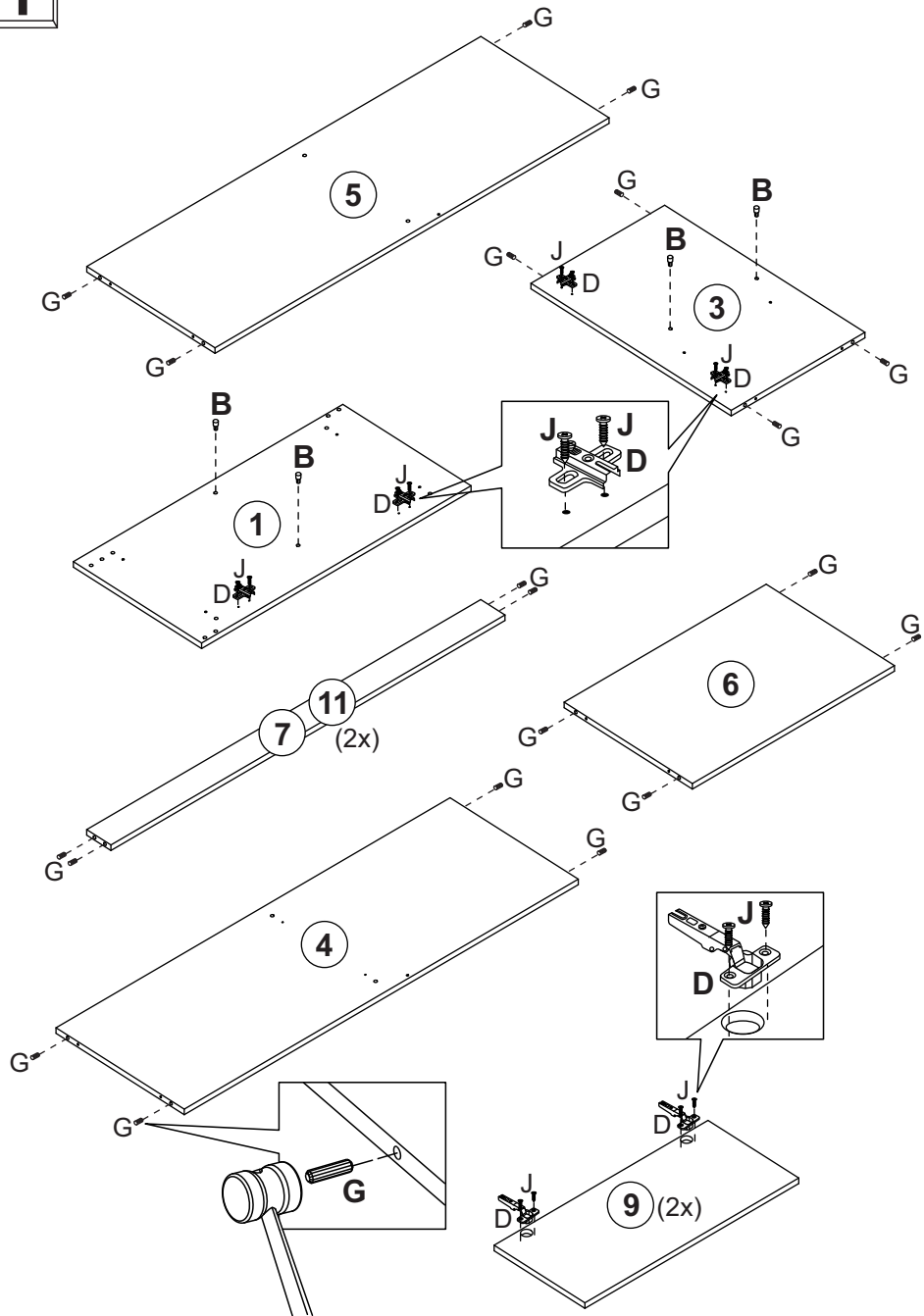

- B (4x)**
- D (2x)**
- G (28x)**
- J (16x)**

2

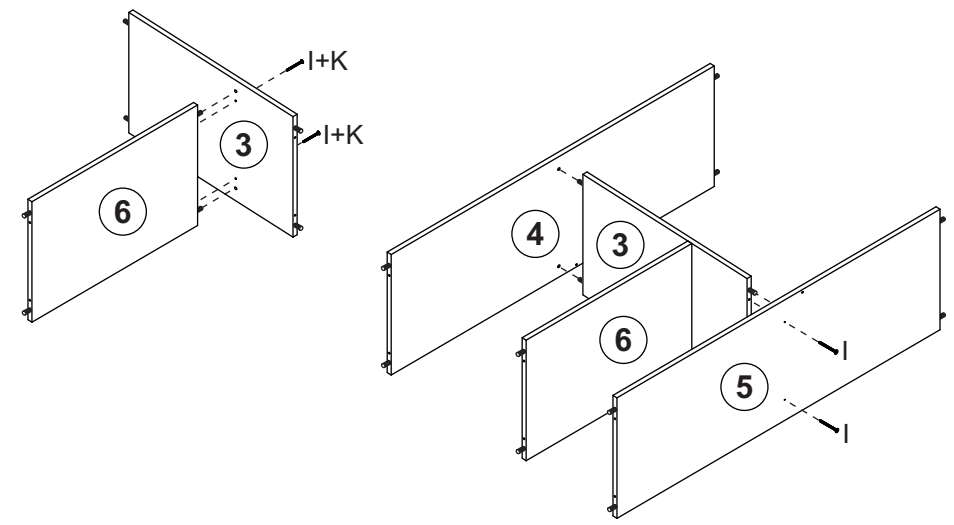

- I (4x)**
- K (2x)**

3

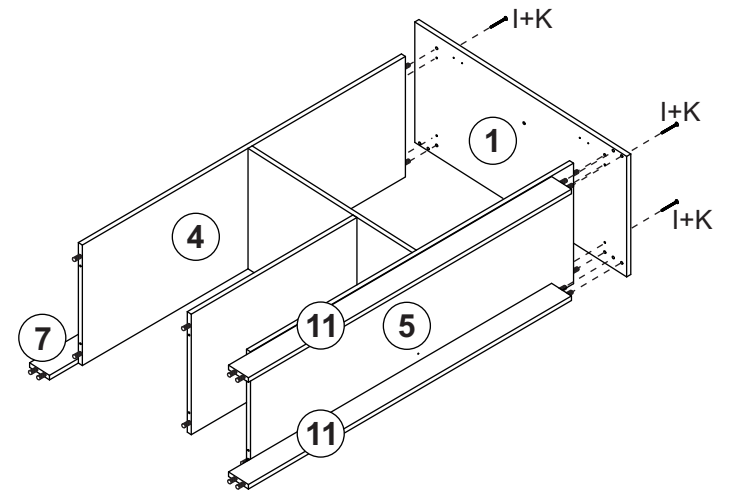

- I (4x)**
- K (4x)**