



JCM
m o v e l a r i a

Camarm Encanto Encanto Dressing Table Tocador Encanto



Cupom: JCM30



Indicamos que a montagem dos produtos seja realizada com parafusadeira eléctrica e por um montador profissional.
We recommend that a professional furniture assembler assemble the product by using a cordless screwdriver.
Se recomienda que un montador de muebles profesional realice el montaje del producto con un destornillador eléctrico.

AVISO: Não nos comprometemos pelo mal-uso, montagem e fixação do produto à parede. Portanto, não somos responsáveis por danos e quedas do produto, eletrônicos e pertences neles contidos. É importante o uso de brocas e ferramentas compatíveis na montagem.
NOTICE: The company is not responsible for the misuse, assembly, and wall fixation, as well as the damages and falls that the products, electronics, and belongings therein might suffer. It is important to use suitable drills and tools to assemble the product.
ATENCIÓN: La empresa no se responsabiliza del mal uso, montaje y fijación del producto a la pared, así como de daños y caídas del producto, electrónicos u objetos. Es importante el uso de taladros y herramientas compatibles con el montaje.

Dica: para evitar possíveis avarias, use a embalagem do produto como apoio durante a montagem.
Tip: to avoid damages, use the product packaging as a base during the assembly.
Pista: para evitar daños, use el envase del producto como apoyo durante el montaje.

RELAÇÃO DE FERRAGENS | HARDWARE LIST | LISTADO DE HERRAJES

CONEXÃO ANGULAR	(A)	CORNER JOINT	(A)	CONEXIÓN ANGULAR	(A)		02
CAVILHA 6x30	(B)	6x30 DOWEL	(B)	CLAVIJA 6x30	(B)		06
CAVILHA 8x30	(C)	8x30 DOWEL	(C)	CLAVIJA 8x30	(C)		01
CHAPA UNIÃO	(D)	4-HOLE CONNECTION PLATE	(D)	PLACA DE UNIÓN 4 AGUJEROS	(D)		04
PARAFUSO 3,5x14	(E)	3.5x14 SCREW	(E)	TORNILLO 3,5x14	(E)		20
PARAFUSO 3,5x12	(F)	3.5x12 SCREW	(F)	TORNILLO 3,5x12	(F)		16
PARAFUSO FLANGEADO 3,5x35	(G)	3.5x35 FLANGE SCREW	(G)	TORNILLO TIPO FLANGE 3,5x35	(G)		07
PARAFUSO 5x40	(H)	5x40 SCREW	(H)	TORNILLO 5x40	(H)		22
PARAFUSO 5x50	(I)	5x50 SCREW	(I)	TORNILLO 5x50	(I)		04
PARAFUSO MINIFIX	(J)	MINIFIX BOLT	(J)	PERNO MINIFIX	(J)		04
PREGO 8x8 C/C	(K)	8x8 NAIL	(K)	CLAVO 8x8	(K)		06
PUXADOR	(L)	HANDLE	(L)	TIRADOR	(L)		01
SACHE DE COLA 10grs	(M)	GLUE SACHET	(M)	BOLSITA DE PEGAMENTO	(M)		01
SAPATA DESLIZANTE	(N)	GLIDE	(N)	PATÍN	(N)		06
TAMBOR MINIFIX	(O)	MINIFIX CAM	(O)	CAJA DEL MINIFIX	(O)		04
PARAFUSO FLANG. 3,5x14	(P)	3.5x14 FLANGE SCREW	(P)	TORNILLO TIPO FLANGE 3,5x14	(P)		04
PARAFUSO CHP CHA BC 3,5x16	(Q)	3.5x16 SCREW	(Q)	TORNILLO 3.5x16	(Q)		02
SUPORTE DE VIDRO PINO 7,5x3,5	(R)	7.5x3.5 GLASS SUPPORT	(R)	SOPORTE CRISTAL 7.5x3.5	(R)		02

RELAÇÃO DE PEÇAS | PARTS LIST | LISTADO DE PARTES



01 Tampo
Top
Tapa 1Pc



02 Lateral Esquerda
Left Side
Lateral Izquierdo 1Pc



03 Lateral Direito
Right Side
Lateral Derecho 1Pc



04 Painel inferior
Stretch
Travesaño 1Pc



05 Frente Gaveta
Drawer Front
Frente Cajón 1Pc



06 Lateral Gaveta
Drawer Side
Laterale Cajón 2Pcs



07 Traseiro Gaveta
Drawer Back
Trasera Cajón 1Pc



08 Prateleira Superior
Top Shelf
Estante Superior 1Pc

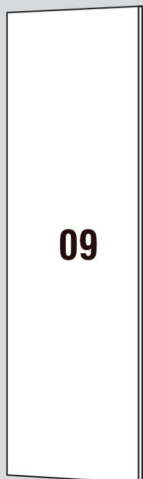

09 Painel Esquerdo
Left Panel
Panel Izquierdo 1Pc



10 Painel Central
Middle Panel
Panel Central 1Pc



11 Painel Direito
Right Panel
Panel Derecho 1Pc



12 Prateleira Inferior Esquerda
Left Bottom Shelf
Estante Inferior Izquierda 1Pc



13 Prateleira Central Esquerda
Left Middle Shelf
Estante Central Izquierda 1Pc



14 Fundo Gaveta
Drawer Bottom
Fondo Cajón 2Pcs



15 Prateleira Superior Esquerda
Left Top Shelf
Estante Superior Izquierda 1Pc

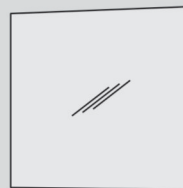

16 Espelho
Mirror
Espejo 1Pc



17 Moldura Menor
Smaller Frame
Moldura Pequena 1Pc



18 Moldura Maior
Bigger Frame
Moldura Grande 1Pc

PASSO 01 ATENÇÃO: ANTES DE EFETUAR A MONTAGEM DO PRODUTO, FAÇA O ENCAIXE DO ACESSÓRIO EM DESTAQUE (MOLDURAS) COM CAVILHA 8x30 (C) E COLA (D), E DEIXE SECAR.

STEP 01 NOTICE: BEFORE ASSEMBLING THE PRODUCT, ATTACH BOTH SMALLER AND BIGGER FRAMES WITH 8x30 DOWELS (C) AND GLUE (D), AND LET THEM DRY.

PASO 01 ATENCIÓN: ANTES DE MONTAR EL PRODUCTO, FIJE LAS MOLDURAS PEQUEÑAS Y GRANDES CON CLAVIJA 8x30 (C) Y PEGAMENTO (D), Y ESPERE A QUE SEQUEN.

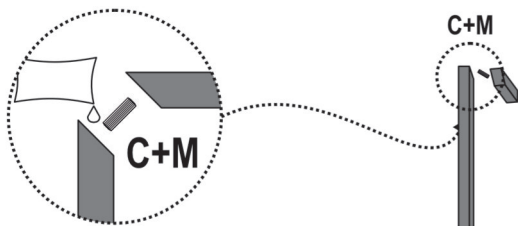

C = 1

M = 1

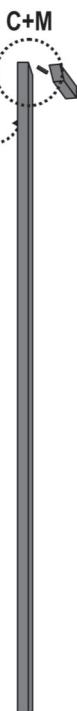

PASSO 03 PARAFUSE AS PEÇAS 10 E 11 NAS PEÇAS 1 E 4 COM PARAFUSO 5x40 (H). PARAFUSE A PEÇA 9 NAS PEÇAS 2 E 12 COM PARAFUSOS 5x40 (H) E PARAFUSO 3,5x35 (G). EFETUE A UNIÃO DOS PAINÉIS COM CHAPA UNIÃO 4 FUROS (D+E).

Step 03 FASTEN PARTS 10 AND 11 TO PARTS 1 AND 4 WITH 5x40 SCREW (H). FASTEN PART 9 TO PARTS 2 AND 12 WITH 5x40 SCREWS (H) AND 3.5x35 SCREWS (G). JOIN THE PANELS WITH 4-HOLE CONNECTION PLATES (D+E).

Paso 03 FIJE LAS PARTES 10 Y 11 A LAS PARTES 1 Y 4 CON TORNILLOS 5x40 (H). FIJE LA PARTE 9 A LAS PARTES 2 Y 12 CON TORNILLOS 5x40 (H) Y TORNILLOS 3,5x35 (G). UNA LOS PANELES CON PLACAS DE UNIÓN 4 AGUJEROS (D+E).

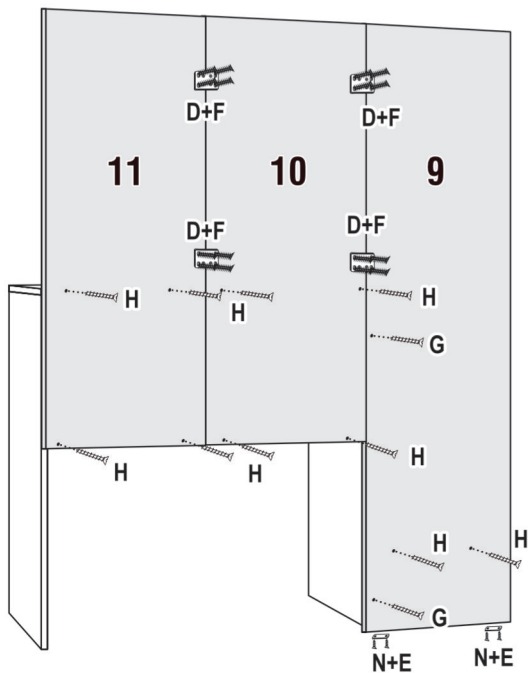

D = 4 F = 16 E = 4 N = 2

G = 2 H = 10

VISTA TRASEIRA
BACK VIEW
VISTA TRASERA

PASSO 02 COMECE A MONTAGEM PELA PEÇA 1. PARAFUSE AS SAPATAS (N+E) NAS PEÇAS 2 E 3, E FIXE-AS NA PEÇA 1 COM MINIFIX (J+O). PARAFUSE A PEÇA 4 NAS PEÇAS 2 E 3 COM PARAFUSO 5x40 (H), E PARAFUSE A PEÇA 12 NA PEÇA 2 COM PARAFUSO 5x40 (H).

Step 02 START THE ASSEMBLY FROM PART 1. FASTEN THE GLIDES (N+E) TO PARTS 2 AND 3, AND FASTEN THEM TO PART 1 WITH MINIFIX (J+O). FASTEN PART 4 TO PARTS 2 AND 3 WITH 5x40 SCREW (H). FASTEN PART 12 TO PART 2 WITH 5x40 SCREW (H).

Paso 02 EMPIECE EL MONTAJE POR LA PARTE 1. FIJE LOS PATINES (N+E) A LAS PARTES 2 Y 3, Y FIJELAS A LA PARTE 1 CON MINIFIX (J+O). FIJE LA PARTE 4 A LAS PARTES 2 Y 3 CON TORNILLO 5x40 (H). FIJE LA PARTE 12 A LA PARTE 2 CON TORNILLO 5x40 (H).

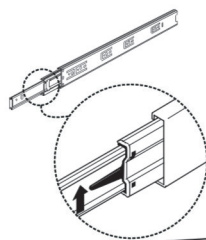

PARA DESTRAVAR A CORREDIÇA LEVANTE A TRAVA E DESENCAIXE AS PARTES, PARAFUSAR UMA PEÇA NA GAVETA E A OUTRA NO HOME CONFORME DESENHOS.

TO LOOSE THE SLIDE, LIFT THE LOCK AND DETACH THE PARTS. SCREW THE PART INTO THE DRAWER, AND THE OTHER INTO THE PRODUCT ACCORDING TO THE PICTURES.

PARA DESTRABAR LA CORREDERA, LEVANTE LA TRABA Y DESENCAJAR LAS PARTES. ATORNILLE LA PARTE AL CAJÓN Y LA OTRA AL PRODUCTO. SEGUN DISEÑOS.

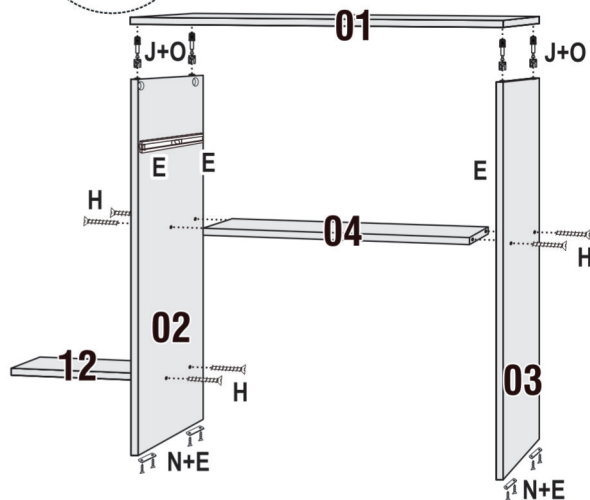

E = 12 H = 6
J = 4 O = 4 N = 4

PASSO 04 PARAFUSE AS PEÇAS 13 E 15 NA PEÇA 9 COM PARAFUSO 5x40 (H).

Step 04 FASTEN PARTS 13 AND 15 TO PART 9 WITH 5x40 SCREW (H).

Paso 04 FIJE LAS PARTES 13 Y 15 A LA PARTE 9 CON TORNILLO 5x40 (H).

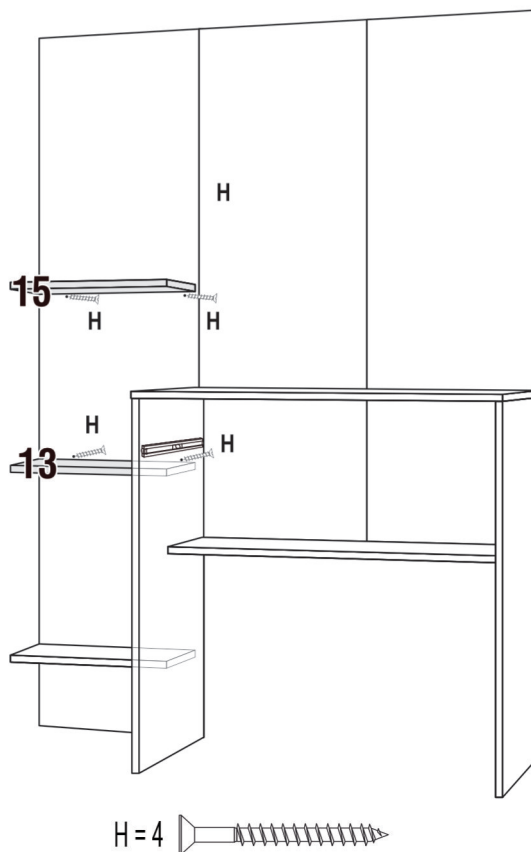

H = 4

Passo 05 PARAFUSE A PEÇA 8 NAS PEÇAS 10, 11 E 9 COM PARAFUSOS 3,5x35 (G) E 5x50 (I), CONFORME O DESENHO.

Step 05 FASTEN PART 8 TO PARTS 10, 11, AND 9 WITH 3.5x35 (G) AND 5x50 (I), ACCORDING TO THE PICTURE.

Paso 05 FIJE LA PARTE 8 A LAS PARTES 10, 11 Y 9 CON TORNILLOS 3,5x35 (G) Y 5x50 (I), SEGÚN EL DISEÑO.

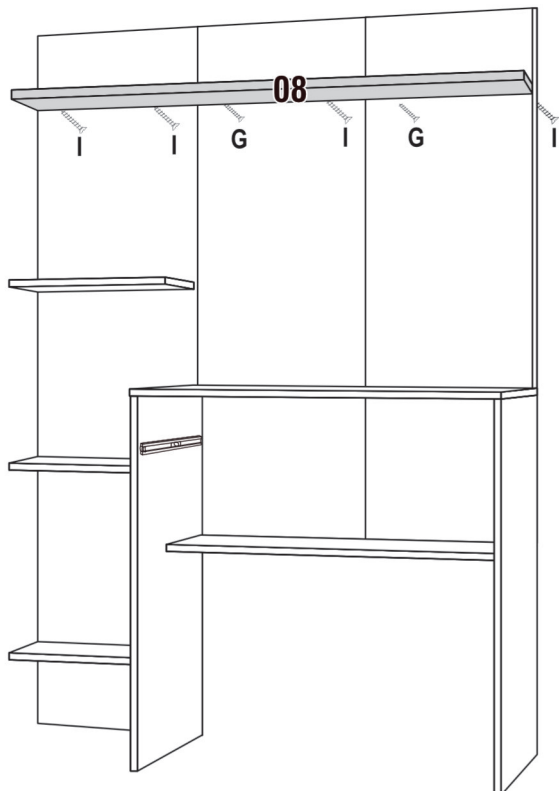

Passo 06 PARAFUSE AS MOLDURAS NAS PEÇAS 9 E 12 COM PARAFUSO 3,5x35.

Step 06 FASTEN THE FRAMES TO PARTS 9 AND 12 WITH 3.5x35 SCREWS.

Paso 06 FIJE LAS MOLDURAS A LAS PARTES 9 Y 12 CON TORNILLOS 3,5x35.

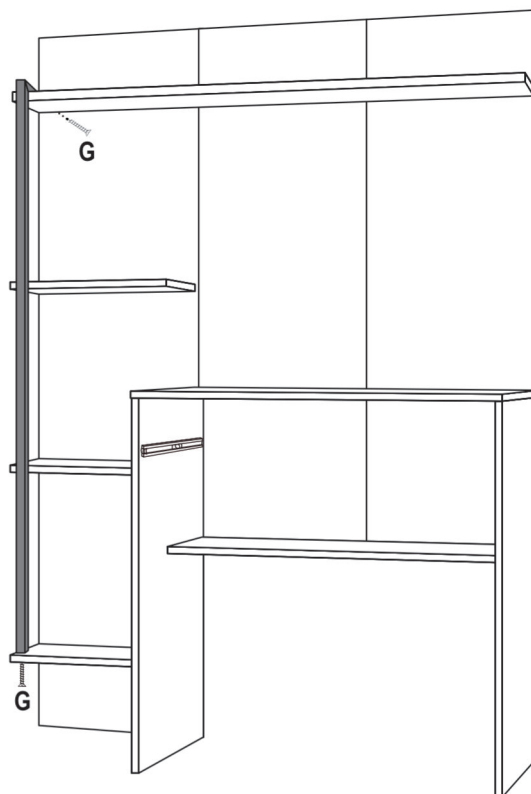

Passo 07 FAÇA A MONTAGEM DAS GAVETAS CONFORME DESENHO E SUAS RESPECTIVAS FERRAGENS.

Step 07 USE THE HARDWARE TO ASSEMBLE THE DRAWERS, ACCORDING TO THE PICTURE.

Paso 07 UTILICE LOS HERRAJES PARA ARMAR LOS CAJONES, SEGÚN EL DISEÑO.

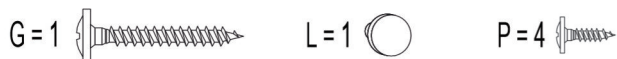
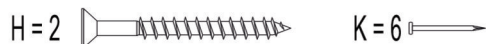
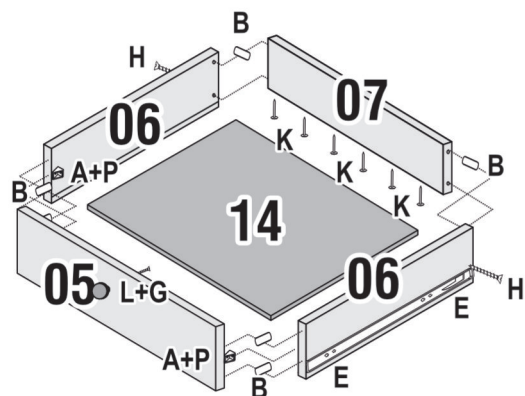

Passo 08 ENCAIXE A GAVETA E PARAFUSE O ESPELHO USANDO O SUPORTE DE VIDRO(R) E PARAFUSO 3,5x16(Q).

Step 08 FIT THE DRAWER AND SCREW THE MIRROR USING THE GLASS SUPPORT(R) AND 3.5x16 SCREW(Q).

Paso 08 AJUSTE EL CAJÓN Y ATORNILLE EL ESPEJO USANDO EL SOPORTE DE VIDRO(R) Y TORNILLO DE 3,5x16(Q).

