

Pesos máximos recomendados com carga distribuída
 Peso máximo recomendado con la carga distribuida
 Recommended maximum weight with distributed load.

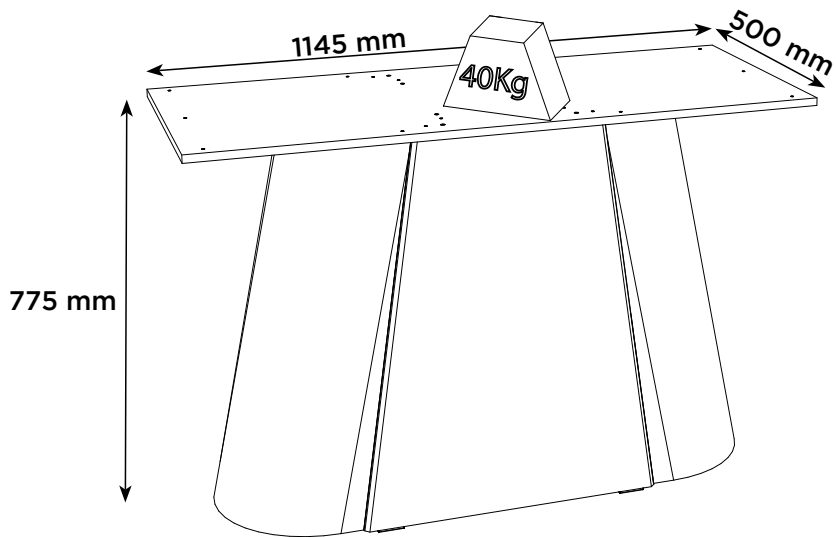

PERFECT CORRECTION
 CORRECCIÓN PERFECTA

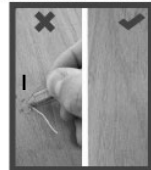

PRODUTO CONCLUÍDO
 PRODUCTO TERMINADO
 FINISHED PRODUCT

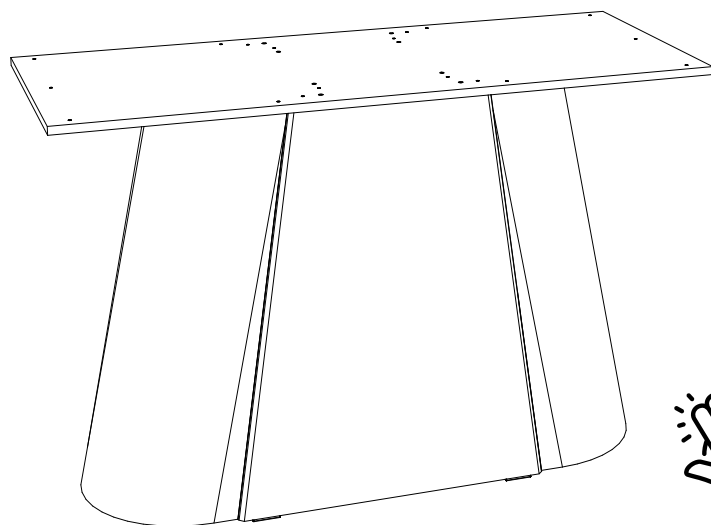

INSTRUÇÕES DE MONTAGEM

INSTRUCCIONES DE MONTAJE
 ASSEMBLY INSTRUCTIONS

BASE MESA OLIVIA | BASE MESA OLIVIA | OLIVIA TABLE BASE

S437-128 Nature

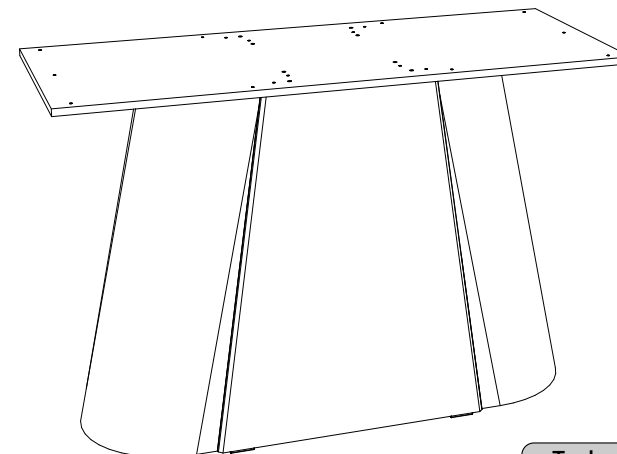

Todas medidas em mm.

Todas las medidas en mm.

All measurements in mm.

AVISO

Para limpeza de seu móvel, use uma flanela seca ou umedecida, e não utilize produtos químicos que possam danificar seu produto.

SISTEMA DE MONTAGEM

O sistema de montagem dos produtos, funciona de acordo com a ordem crescente dos números indicados no desenho. Ex: 01, 02, 03, 04... até a conclusão da montagem.

ASSISTÊNCIA TÉCNICA

Para solicitação de Assistência Técnica você consumidor deverá entrar em contato com o Lojista o qual você realizou a compra deste produto e solicitar a assistência técnica das peças avariadas. A garantia abrange todas as peças, partes e componentes que eventualmente venham apresentar defeito de fabricação no prazo de 03 (três) meses, contando a partir da entrega do produto ao consumidor, mediante nota fiscal de compra. Se houver qualquer alteração na estrutura do produto ou ocorrer defeito por negligência do montador/consumidor em relação a instrução de montagem e manuseio, não será fornecido assistência técnica gratuita.

ADVERTENCIA

Para limpieza de su móvil, use una franela seca o húmeda, y no utilice productos químicos que puedan dañar su producto.

SISTEMA DE MONTAJE

El sistema de montaje de los productos funciona de acuerdo con el orden creciente de los números indicados en el dibujo. Ej.: 01, 02, 03, 04... hasta la conclusión del montaje.

ASISTENCIA TÉCNICA

Para solicitar Asistencia Técnica, el consumidor debe comunicarse con el Comercio que usted realizó la compra de este producto y solicita asistencia técnica para las partes dañadas. La garantía cubre todas las partes, piezas y componentes que eventualmente puedan presentar defecto de fabricación en el plazo de 03 (tres) meses, contados a partir de la entrega del producto al consumidor, mediante factura de compra. Si se produce algún cambio en la estructura del producto o se produce un defecto por negligencia del montador/consumidor en relación con las instrucciones de montaje y manipulación, no se prestará asistencia técnica gratuita.

NOTICE

To clean your furniture, use a dry or wet cloth, and do not use chemicals that may damage your product.







ASSEMBLY SYSTEM

The products' assembly system works according to the increasing order of the indicated numbers. For example: 01, 02, 03, 04 ... to the end of the assembly.

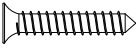
TECHNICAL ASSISTANCE

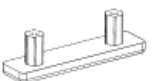
To request Technical Assistance, the consumer must contact the retailer from whom you purchased this product and request technical assistance for the damaged parts. The warranty covers all parts, parts and components that may eventually present a manufacturing defect within a period of 03 (three) months, counting from the delivery of the product to the consumer, by means of a purchase invoice. If there is any change in the structure of the product or defect occurs due to negligence of the assembler/consumer in relation to the assembly and handling instruction, free technical assistance will not be provided.

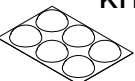
ACESSÓRIOS | ACCESORIOS | ACCESSORIES

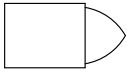
A x8  Parafuso 3,5x40mm CHT.	B x50  Parafuso 4,0x25mm CHT.	C x48  Parafuso 3,5x12mm CHT.	D x20  Cavilha 5x25mm.
E x4  Sapata 4x50x12mm.	F x12  Cantoneira 17,5 x 17,5 x 44mm.	G KIT x2  Kit Batente de Silicone (6 Und).	H x1  Sachê de Cola.
I x2  Giz de Correção.			

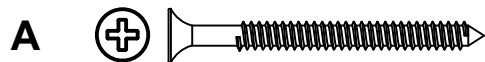

PARAFUSOS EM ESCALA 1:1 | TORNILLOS A ESCALA 1:1 | 1:1 SCALE SCREWS

Opção de Montagem com o Tampo 2000x1000
canto moeda com Vidro Incolor (S927-128)

Opción de montaje con parte superior 2000x1000
Esquina de monedas con vidrio Incoloro (S927-128)

Mounting Option with Top 2000x1000
Coin corner with Glass Colorless (S927-128)

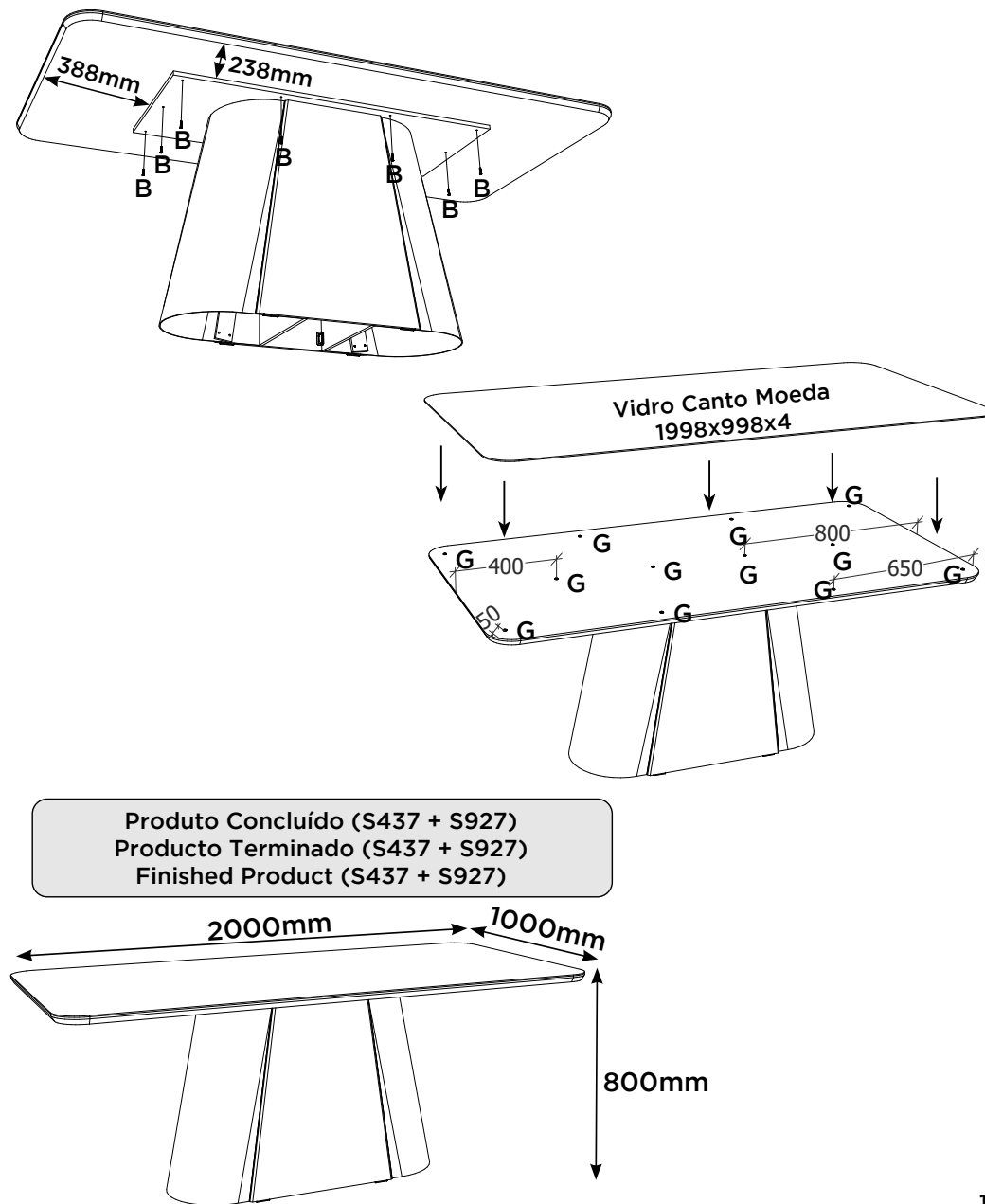

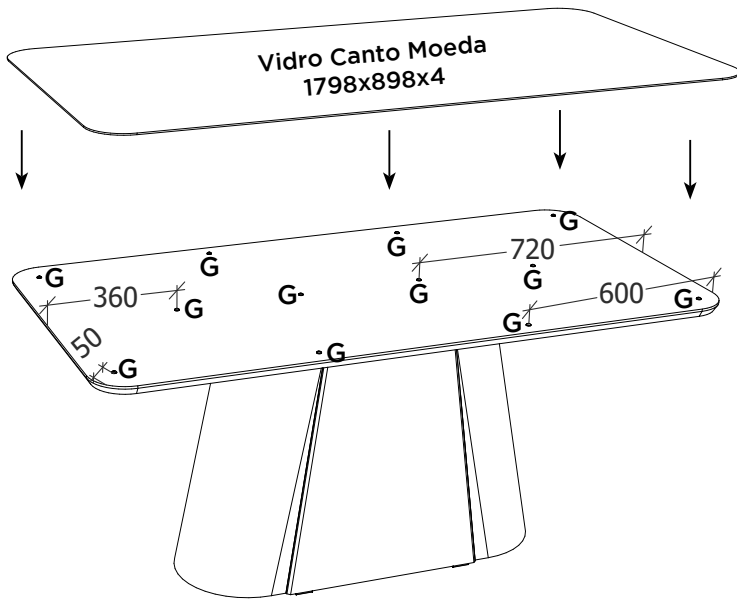

A pintura do Vidro deve ficar virada para baixo, depois ajustá-lo sobre os batentes de silicone (G)

La pintura de vidrio debe mirar hacia abajo, luego ajustarla sobre los topes de silicona (G)

The glass paint should be facing downwards, then adjust it over the silicone stops (G)

Produto Concluído (S437 + S922)
Producto Terminado (S437 + S922)
Finished Product (S437 + S922)

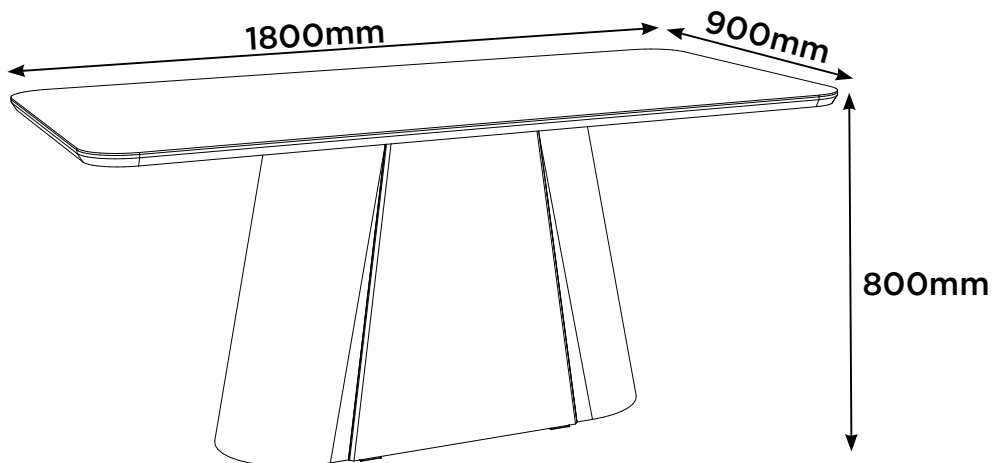

LISTA DE PEÇAS | LISTA DE PIEZAS | LIST OF PIECES

Item	Caixa Caja Box	Qtd Ctd Qty	Descrição Descripción Description	Dimensões (mm) Dimensiones (mm) Dimensions (mm)		
				Comprimento Largo Length	Largura Ancho Width	Espessura Grosor Thickness
1	1/1	02	LATERAL LADO SIDE	751	580	12
2	1/1	02	LATERAL CRU LADO CRUDO RAW SIDE	751	396	12
3	1/1	02	FUNDO FONDO BOTTOM	1015	816	3
4	1/1	04	TRAVESSA TRAVESAÑO CROSSBOARD	745	60	12
5	1/1	01	TAMPO ESTRUTURAL TAPA ESTRUCTURAL STRUCTURAL TOP	1200	500	15

VISTA EXPLODIDA DAS PEÇAS | VISTA DESPIECE DE LAS PIEZAS | EXPLODED VIEW OF THE PARTS

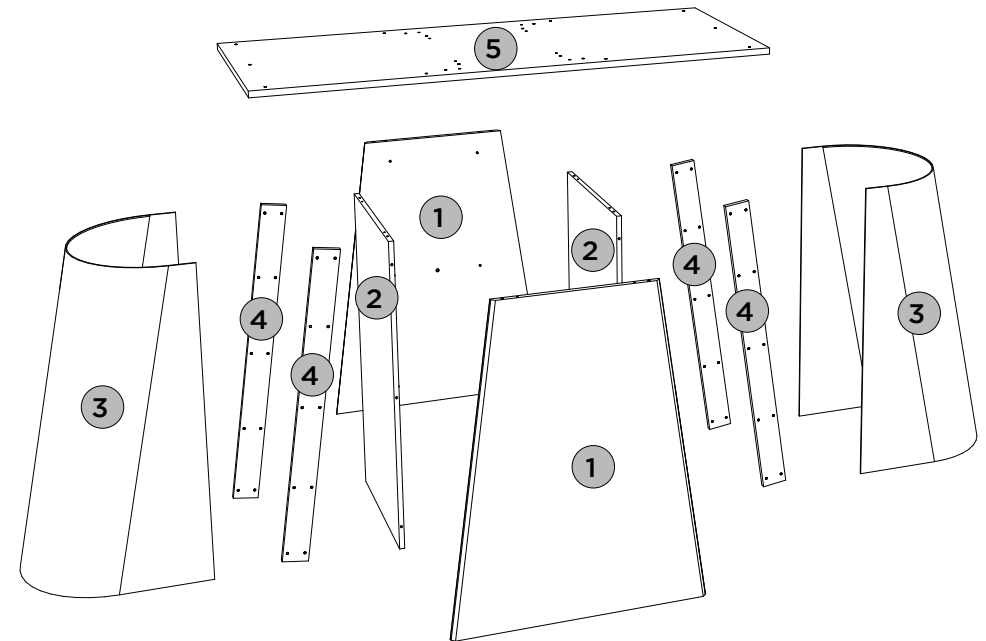

REQUISITOS PARA MONTAGEM REQUISITOS PARA LA MONTAJE | ASSEMBLY REQUIREMENTS.

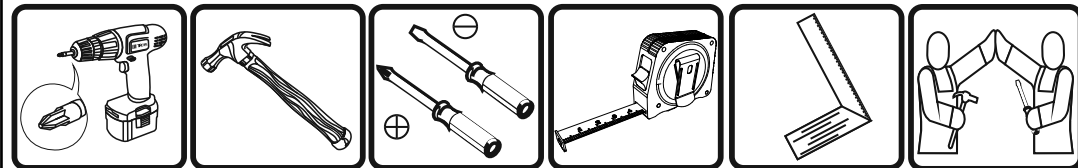

Imagens meramente ilustrativas, não acompanha o produto.
Imágenes ilustrativas, no incluidas con el producto.
Illustrative images, not included with the product.

PEÇAS REQUERIDAS

1	LATERAL	x2
2	LATERAL CRU	x2

ACESSÓRIOS REQUERIDOS

C		24
D		20
E		04
F		12
H		

FERRAMENTAS NECESSÁRIAS

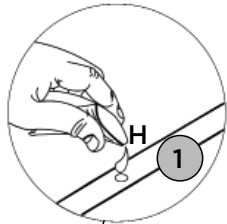
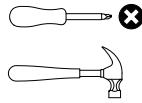

Colocar cola na fixação da sapata.

Ponga pegamento en la fijación del zapato.

Put glue on the shoe fixing.

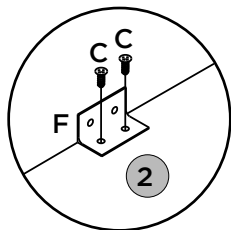
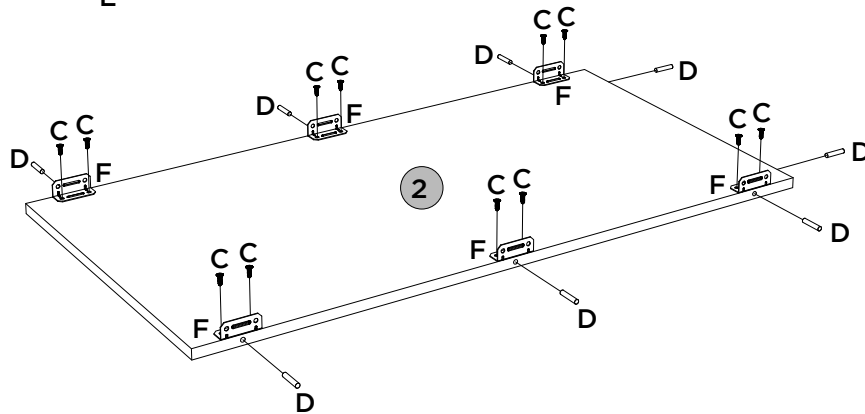
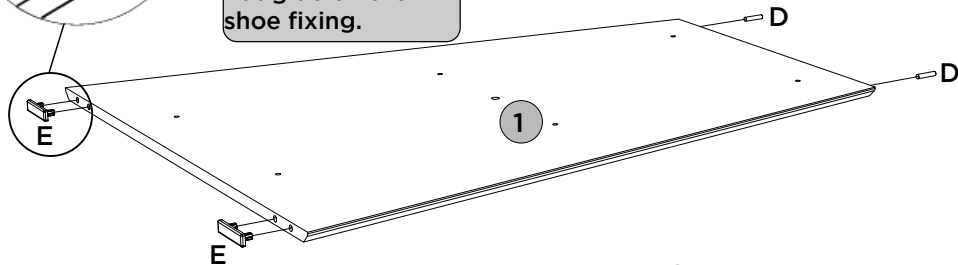

Utilizar o sachê de cola (H) em todas as cavilhas (D) do produto.

Con el pegamento sobre (H) en todos los pernos (D) producto.

Use the glue sachet (H) on all the pegs (D) of the product.



Produto Concluído (S437 + S910)
Producto Terminado (S437 + S910)
Finished Product (S437 + S910)

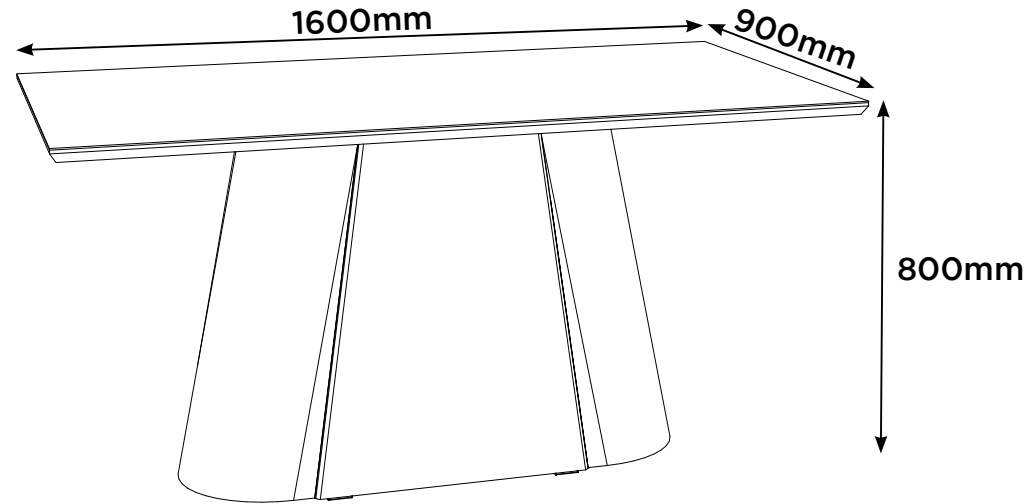

Opção de Montagem com o Tampo 1800x900 canto moeda com Vidro (S922-139)

Opción de montaje con parte superior 1800x900 Esquina de monedas con vidrio (S922-139)

Mounting Option with Top 1800x900 Coin corner with Glass (S922-139)

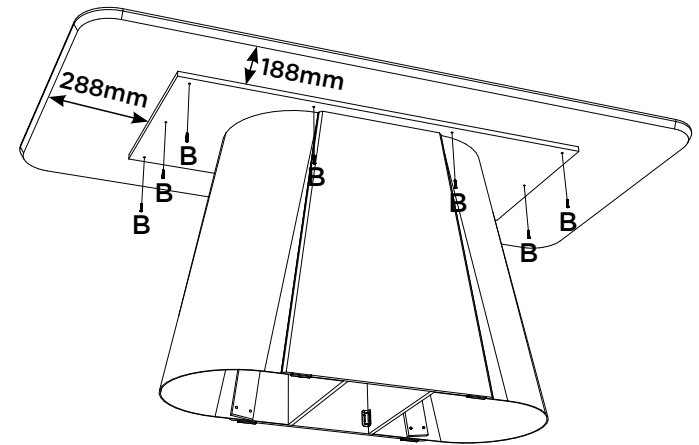

Produto Concluído (S437 + S909)
 Producto Terminado (S437 + S909)
 Finished Product (S437 + S909)

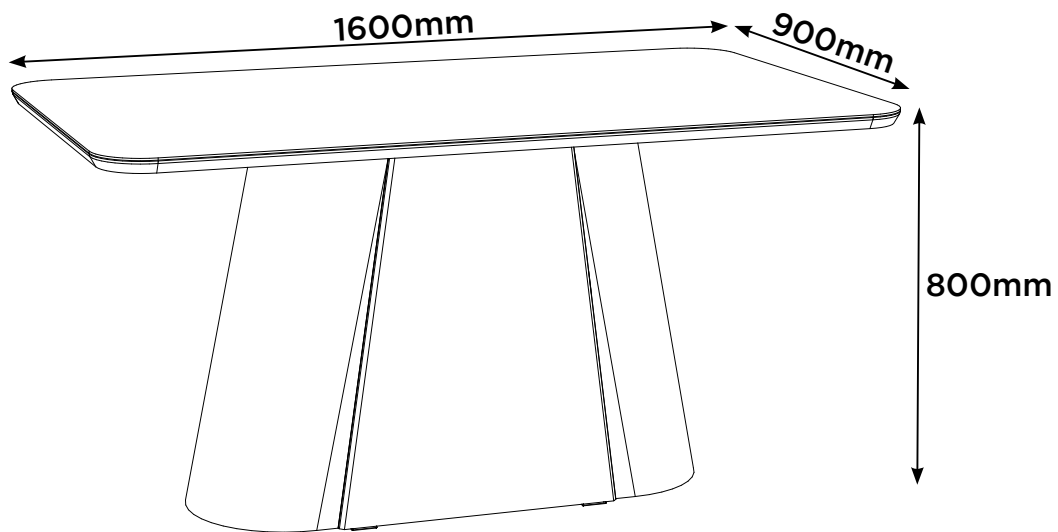

Opção de Montagem com o Tampo 1600x900
 canto reto sem Vidro (S910-139)

Opción de montaje con parte superior 1600x900
 esquina recta sin vidrio (S910-139)

Mounting Option with Top 1600x900
 straight corner without Glass (S910-139)

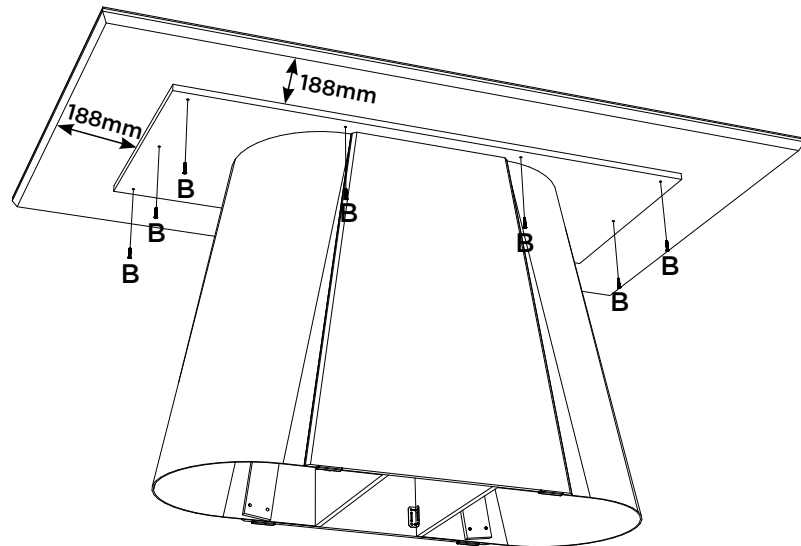

MONTAGEM 1 | MONTAJE 1 | ASSEMBLY 1

PEÇAS REQUERIDAS

1	LATERAL	x2
2	LATERAL CRU	x2

ACESSÓRIOS REQUERIDOS

C		24
H		

FERRAMENTAS NECESSÁRIAS

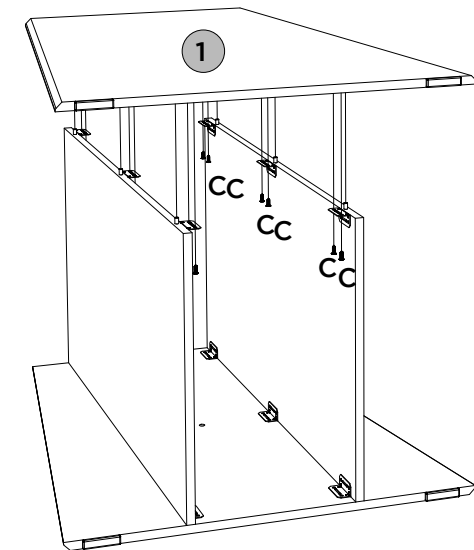
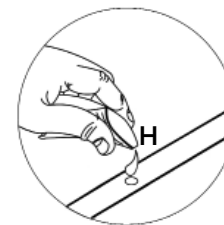
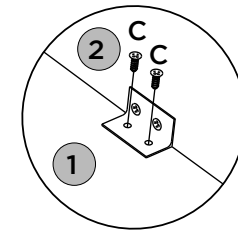
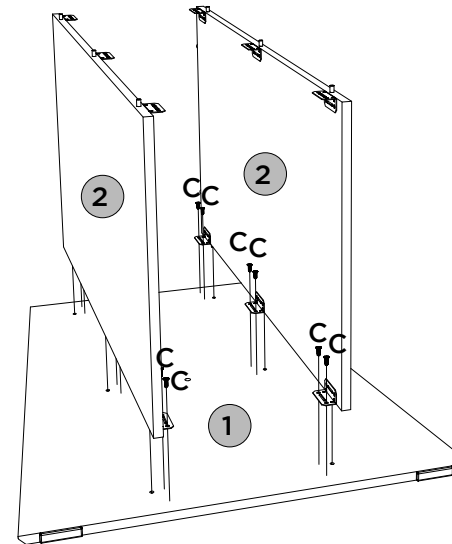

PEÇAS REQUERIDAS

ACESSÓRIOS REQUERIDOS

FERRAMENTAS NECESSÁRIAS

3	FUNDO	x2
4	TRAVESSA	x4

B		40
---	--	----

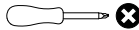

Alinhar a Traveça (4) com a Lateral (1)

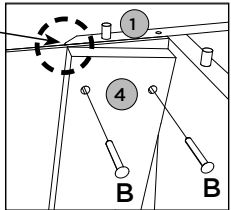

Alinee la Travesaño (4) con el Lateral (1)

Align the Traverse (4) with the Side (1)

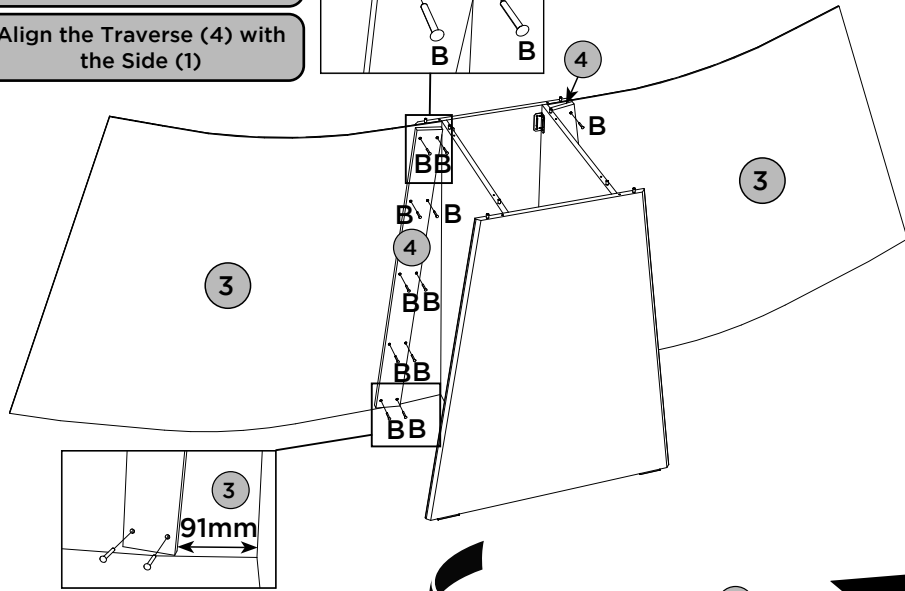

Alinhar o Fundo (3) com a Lateral Cru (2)

Alinee la parte inferior (3) con el lado sin rematar (2)

Align the Bottom (3) with the Raw Side (2)

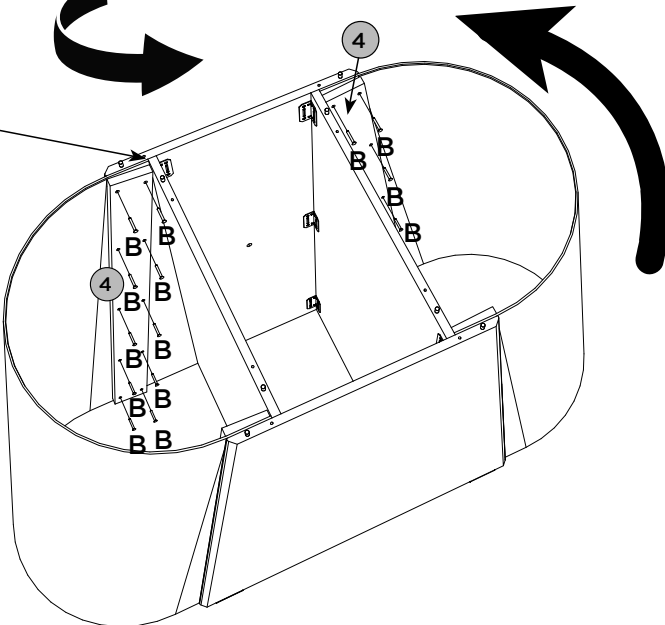

Opção de Montagem com o Tampo 1600x900 canto moeda com Vidro (S909-128/139)

Opción de montaje con parte superior 1600x900 Esquina de monedas con vidrio (S909-128/139)

Mounting Option with Top 1600x900 Coin corner with Glass (S909-128/139)

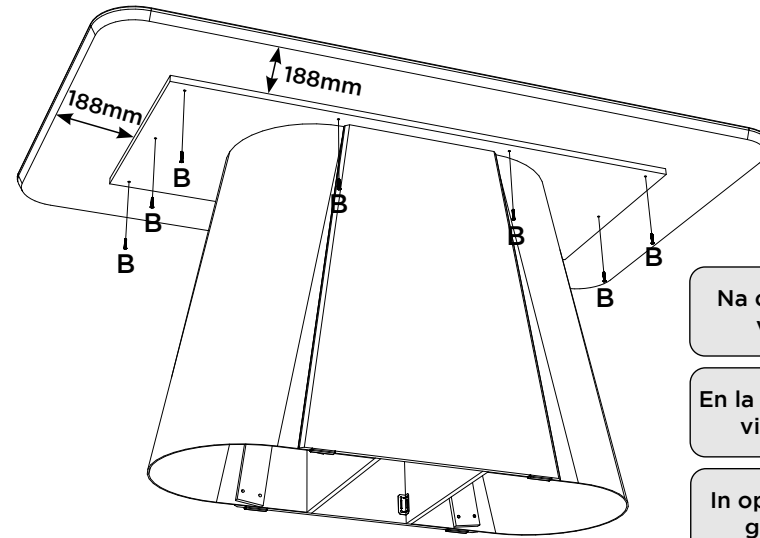

Na opção S909-128 o vidro é incolor

En la opción S909-128 el vidrio es incoloro

In option S909-128 the glass is colorless

S909-139
A pintura do Vidro deve ficar virada para baixo, depois ajustá-lo sobre os batentes de silicone (G)

S909-139
La pintura de vidrio debe mirar hacia abajo, luego ajustarla sobre los topes de silicona (G)

S909-139
The glass paint should be facing downwards, then adjust it over the silicone stops (G)

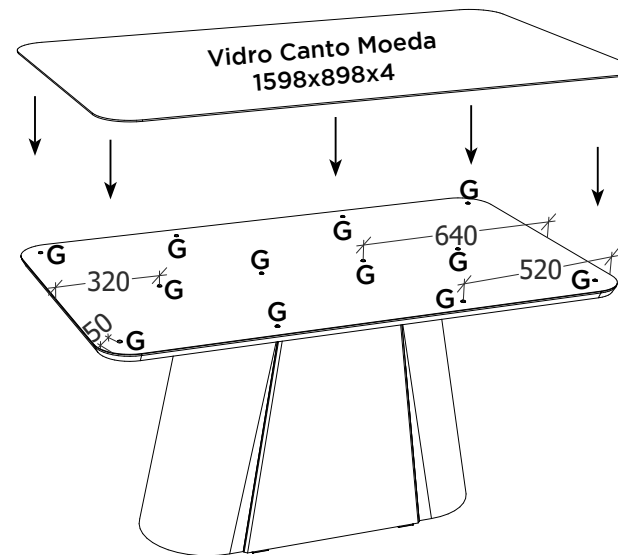

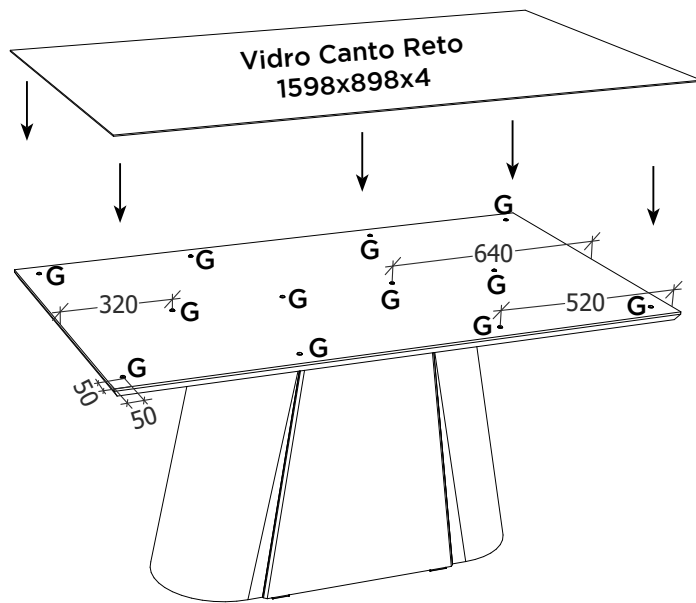

A pintura do Vidro deve ficar virada para baixo, depois ajustá-lo sobre os batentes de silicone (G)

La pintura de vidrio debe mirar hacia abajo, luego ajustarla sobre los topos de silicona (G)

The glass paint should be facing downwards, then adjust it over the silicone stops (G)

Produto Concluído (S437 + S908)
Producto Terminado (S437 + S908)
Finished Product (S437 + S908)

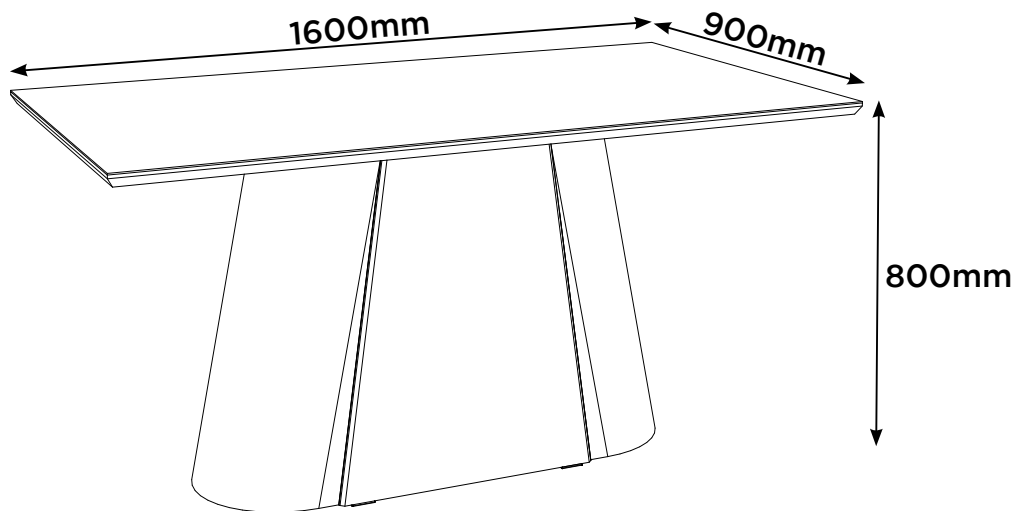

MONTAGEM 3 | MONTAJE 3 | ASSEMBLY 3

PEÇAS REQUERIDAS

5	TAMPO ESTRUTURAL	x1
---	------------------	----

ACESSÓRIOS REQUERIDOS

A		08
H		

FERRAMENTAS NECESSÁRIAS

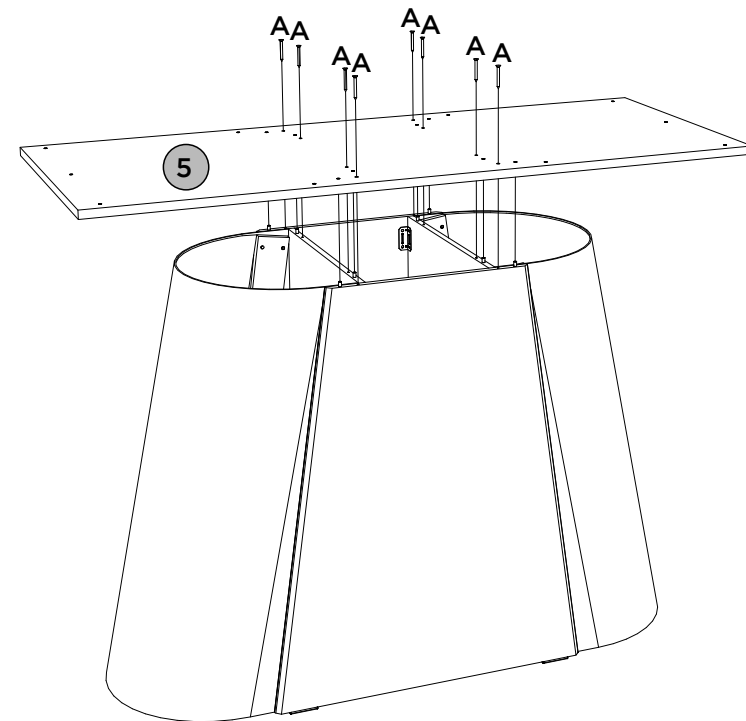
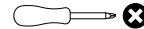

Opção de Montagem com o Tampo 2000x900
canto moeda com Vidro (S907-139)

Opción de montaje con parte superior 2000x900
Esquina de monedas con vidrio (S907-139)

Mounting Option with Top 2000x900
Coin corner with Glass (S907-139)

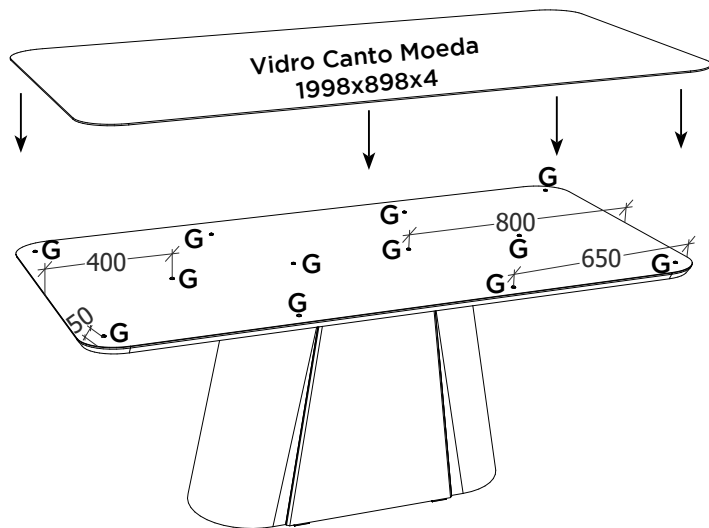
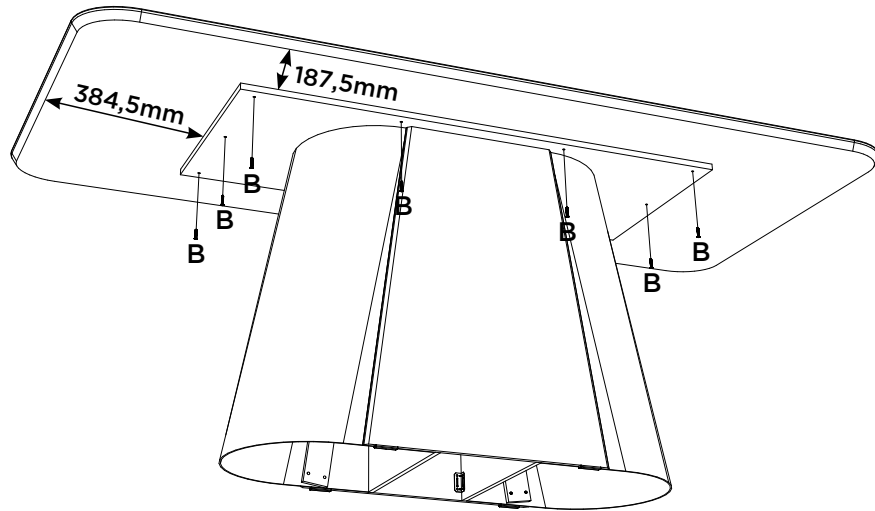

A pintura do Vidro
deve ficar virada
para baixo, depois
ajustá-lo sobre os
batentes de silicone
(G)

La pintura de
vidrio debe mirar
hacia abajo, luego
ajustarla sobre los
topes de silicona
(G)

The glass paint
should be facing
downwards, then
adjust it over the
silicone stops (G)

Produto Concluído (S437 + S907)
Producto Terminado (S437 + S907)
Finished Product (S437 + S907)

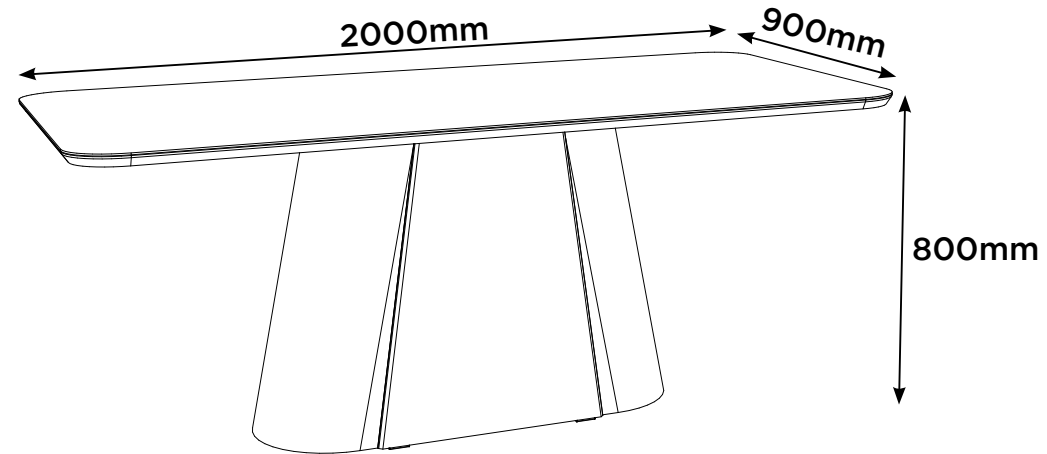

Opção de Montagem com o Tampo 1600x900
canto reto com Vidro (S908-139)

Opción de montaje con parte superior 1600x900
esquina recta con vidrio (S908-139)

Mounting Option with Top 1600x900
straight corner with Glass (S908-139)

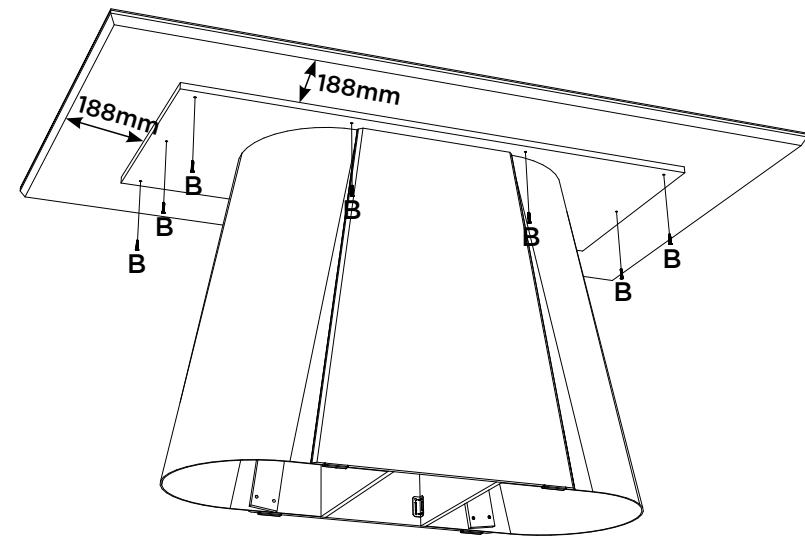

Item	Caixa Caja Box	Qtd Ctd Qty	Descrição Descripción Description	Medidas (mm) Dimensions (mm) Size (measurements) (mm)
01	1/1	02	Encosto Estofado Respaldo tapizado Upholstered backrest	655x425x90
02	1/1	02	Assento Estofado Asiento tapizado Upholstered seat	460x425x145
03	1/1	04	Pé Frontal Pie delantero Front foot	425x40x25
04	1/1	04	Pé Traseiro Pie trasero Back foot	425x130x25
05	1/1	04	Travessa Lateral Plato lateral Side Platter	336x80x15
06	1/1	04	Travessa Plato Platter	336x80x15
07	1/1	02	Moldura Superior Marco superior Top Frame	420x25x25

O volume contém peças para montagem de 2 Cadeiras.
El volumen contiene piezas para montar 2 sillas.
The volume contains parts for mounting 2 Chairs.

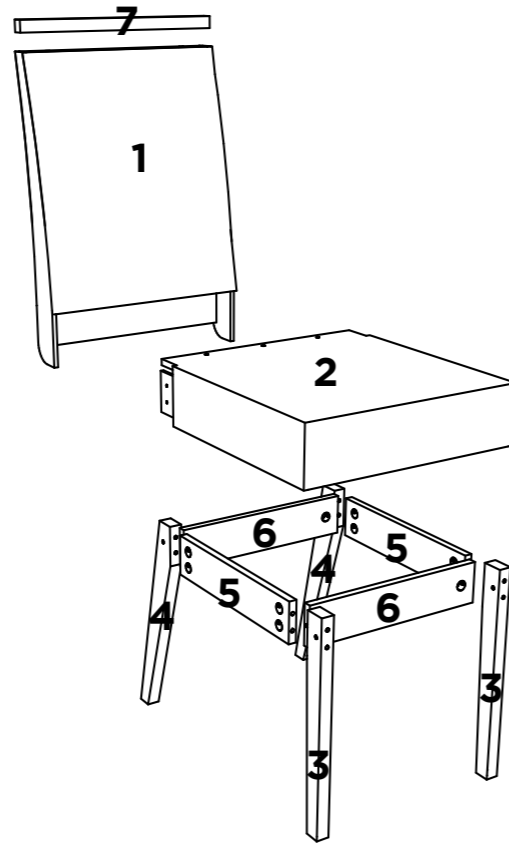

Ferragens | Herrajes | Hardware

A 16x Parafuso Cab PL 17 Allen 4.14x3,12 (80mm) Tornillo PL 17 Allen 4.14x3.12 (80mm) Screw PL 17 Allen 4.14x3.12 (80mm)	B 08x Parafuso Cab PL 17 Allen 4.14x3,12 (60mm) Tornillo PL 17 Allen 4.14x3.12 (60mm) Screw PL 17 Allen 4.14x3.12 (60mm)	C 06x Parafuso 7,0x40mm CHT Allen Tornillo Allen CHT de 7,0x40 mm Screw 7.0x40mm CHT Allen	D 64x Parafuso 4,0x14mm CHT Tornillo 4,0x14mm CHT Screw 4,0x14mm CHT
E 24x Porca meia lua plástica rosca 1/4 1/4 tuerca de media luna de plástico 1/4 plastic half moon nut	F 08x Sapata Deslizante 15x26x8mm Zapato deslizante 15x26x8mm Sliding Shoe 15x26x8mm	G 12x Cantoneira 17,5x17,5x44 Cantonera 17,5x17,5x44 Angle 17,5x17,5x44	H 16x Parafuso 3,0x16mm CHT Tornillo 3,0x16mm CHT Screw 3,0x16mm CHT
I 01x Chave Allen llave Allen Allen key	J 08x Cantoneira metal 18x18 Cantonera metálica 18x18 18x18 metal angle bracket	K 01x Sachê de cola Bolsa de pegamento Glue bag	L 01x Giz de correção Tiza de corrección Chalk of correction
M 04x Cavilha Madeira 10x35mm Taco de madera de 10x35 mm 10x35mm wooden dowel			

CADEIRA NINA

S32-502 Nature/Linho
S32-510 Nature/Marrom Amêndoa
S32-511 Nature/Marrom Espresso
S32-538 Nature/Creme

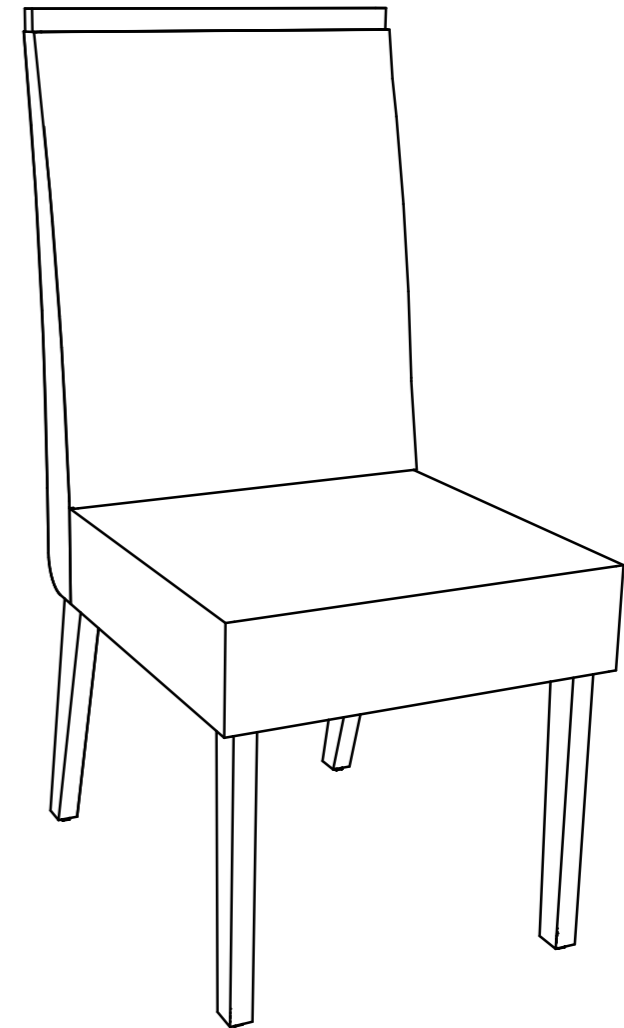

Requisitos para montagem
Requisitor para la montaje
Assembly Requirements

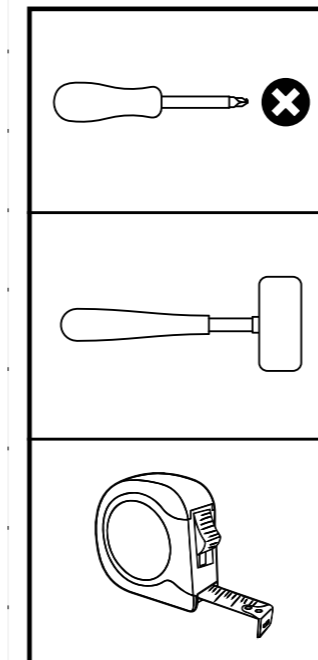

Imagens meramente ilustrativas,
não acompanha o produto.
Imágenes ilustrativas, no incluidas
con el producto.
Illustrative images, not included
with the product.

AVISO

Para limpeza de seu móvel, use uma flanela seca ou umedecida, e não utilize produtos químicos que possam danificar seu produto.

SISTEMA DE MONTAGEM

O sistema de montagem dos produtos, funciona de acordo com a ordem crescente dos números indicados no desenho. Ex: 01, 02, 03, 04... até a conclusão da montagem.

ASSISTÊNCIA TÉCNICA

Para solicitação de Assistência Técnica você consumidor deverá entrar em contato com o Lojista o qual você realizou a compra deste produto e solicitar a assistência técnica das peças avariadas. A garantia abrange todas as peças, partes e componentes que eventualmente venham apresentar defeito de fabricação no prazo de 03 (três) meses, contando a partir da entrega do produto ao consumidor, mediante nota fiscal de compra. Se houver qualquer alteração na estrutura do produto ou ocorrer defeito por negligência do montador/consumidor em relação a instrução de montagem e manuseio, não será fornecido assistência técnica gratuita.

ADVERTENCIA

Para limpieza de su móvil, use una flanela seca o húmeda, y no utilice productos químicos que puedan dañar su producto.

SISTEMA DE MONTAJE

El sistema de montaje de los productos funciona de acuerdo con el orden creciente de los números indicados en el dibujo. Ej.: 01, 02, 03, 04... hasta la conclusión del montaje.

ASISTENCIA TÉCNICA

Para solicitar Asistencia Técnica, el consumidor debe comunicarse con el Comercio que usted realizó la compra de este producto y solicita asistencia técnica para las partes dañadas. La garantía cubre todas las partes, piezas y componentes que eventualmente puedan presentar defecto de fabricación en el plazo de 03 (tres) meses, contados a partir de la entrega del producto al consumidor, mediante factura de compra. Si se produce algún cambio en la estructura del producto o se produce un defecto por negligencia del montador/consumidor en relación con las instrucciones de montaje y manipulación, no se prestará asistencia técnica gratuita.

NOTICE

To clean your furniture, use a dry or wet cloth, and do not use chemicals that may damage your product.

ASSEMBLY SYSTEM

The products' assembly system works according to the increasing order of the indicated numbers. For example: 01, 02, 03, 04 ... to the end of the assembly.

TECHNICAL ASSISTANCE





To request Technical Assistance, the consumer must contact the retailer from whom you purchased this product and request technical assistance for the damaged parts. The warranty covers all parts, parts and components that may eventually present a manufacturing defect within a period of 03 (three) months, counting from the delivery of the product to the consumer, by means of a purchase invoice. If there is any change in the structure of the product or defect occurs due to negligence of the assembler/consumer in relation to the assembly and handling instruction, free technical assistance will not be provided.

1 Pré Montagem Preasamblea | Pre-assembly

Peças Necessárias | Partes requeridas | Required Parts:

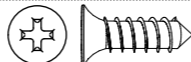
3	Pé Frontal Pie delantero Front foot	04
4	Pé Traseiro Pie trasero Back foot	04
5	Travessa Lateral Plato lateral Side Platter	04
6	Travessa Plato Platter	04

Ferragens | Herrajes | Hardware:

D		x24
F		x08
G		x16
I		
K		

Ferramentas | Instrumentos | Tools:

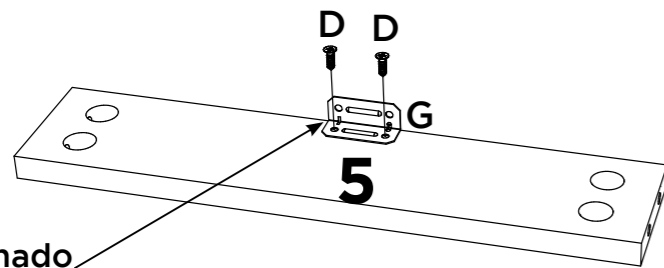
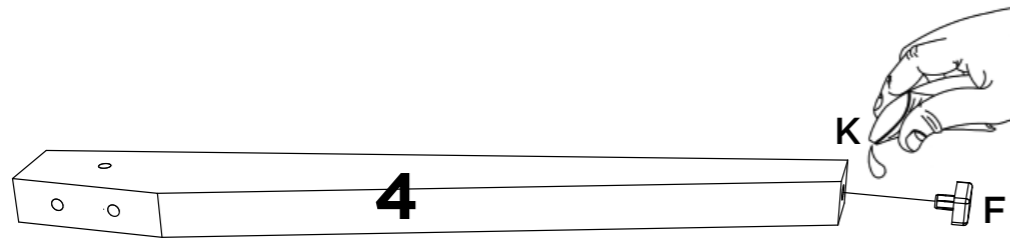
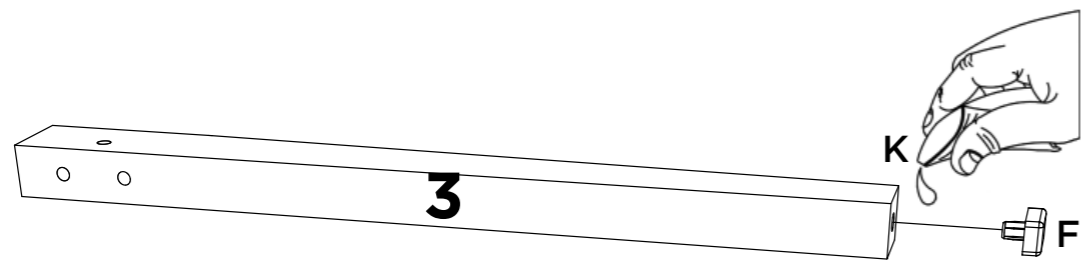
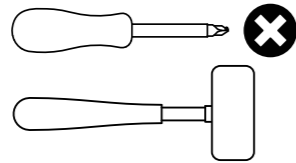

*Alinhado
*Alineado
*Aligned

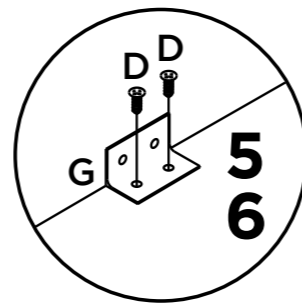
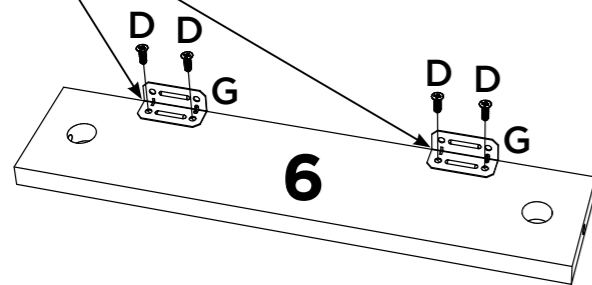

6

Ferragens | Herrajes | Hardware:

L		x01
---	-------------------------------------------------------------------------------------	-----

Pesos máximos recomendados com carga distribuída
Peso máximo recomendado con la carga distribuida
Recommended maximum weights with evenly distributed.

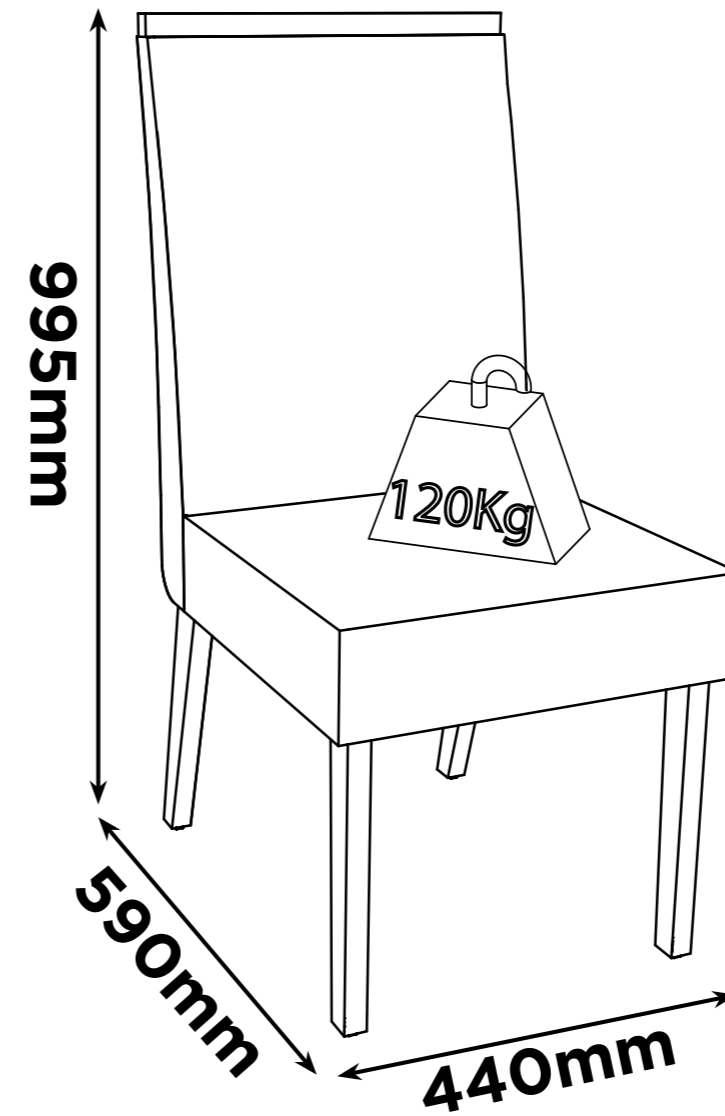



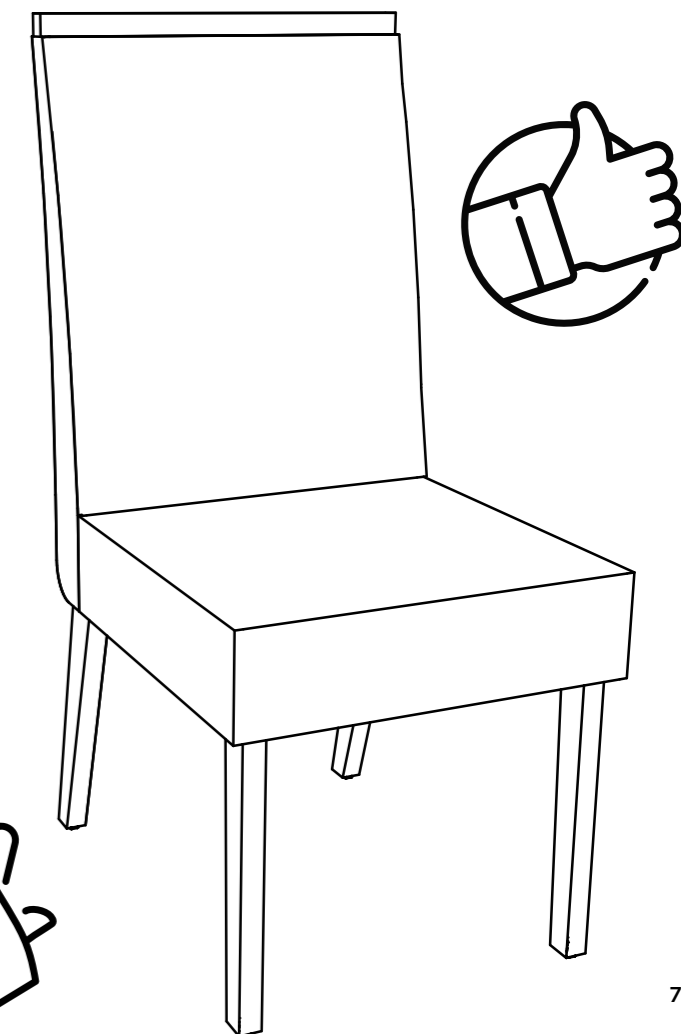
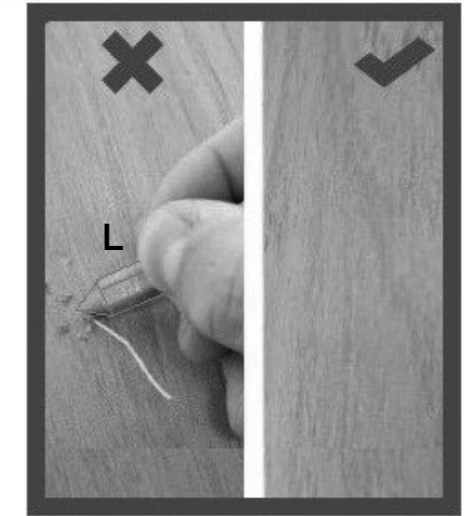

PERFECT CORRECTION
CORRECCIÓN PERFECTA



Peças Necessárias | Partes requeridas | Required Parts:

7	Moldura Superior Marco superior Top Frame	02
---	-----------------------------------------------	----

Ferragens | Herrajes | Hardware:

D		x40
J		x08
K		
M		04

Ferramentas | Instrumentos | Tools:

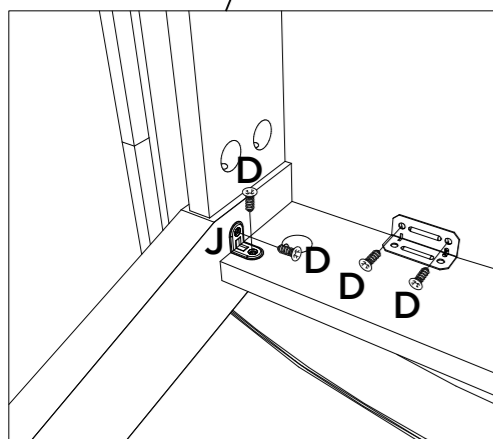
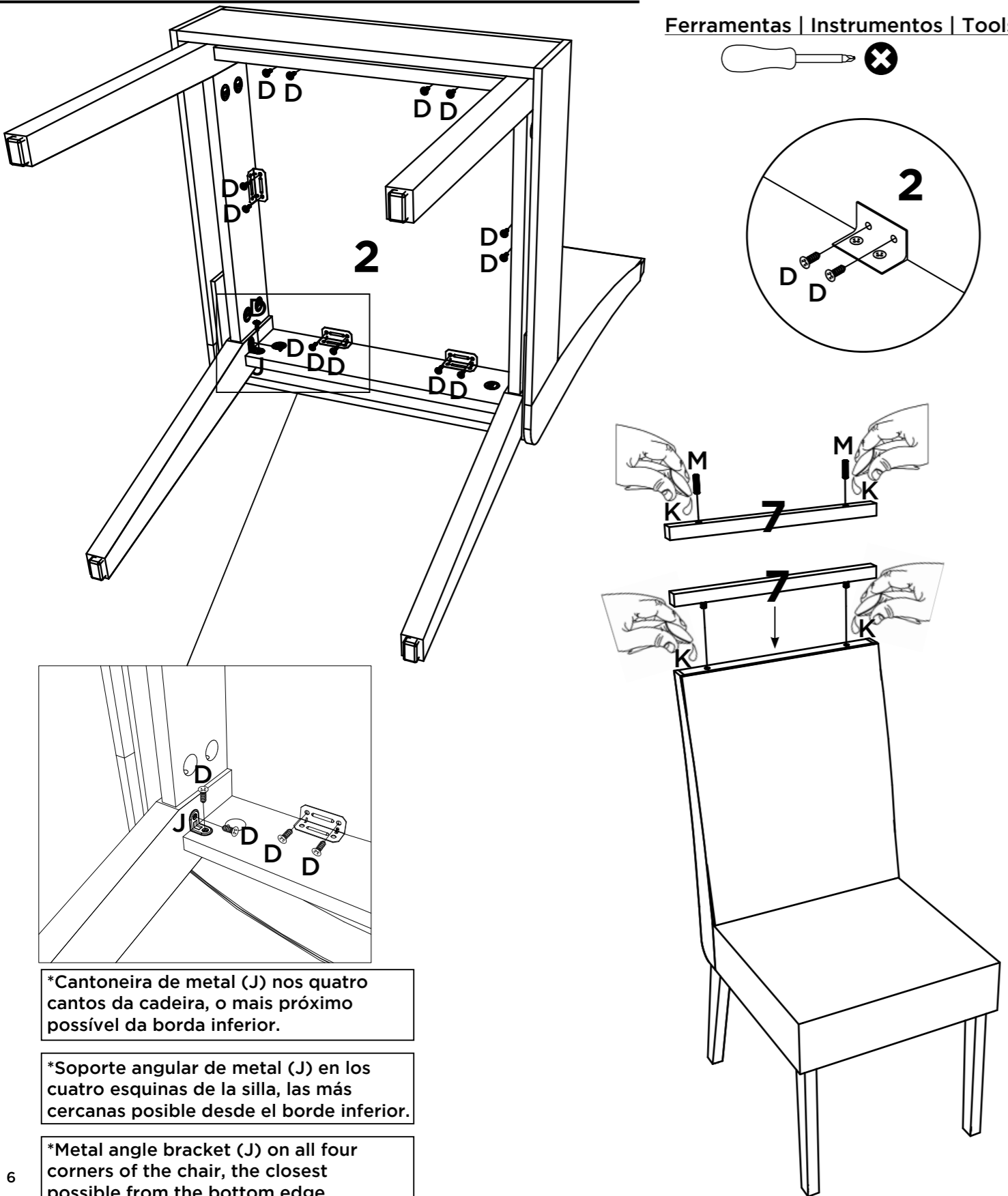

*Cantoneira de metal (J) nos quatro cantos da cadeira, o mais próximo possível da borda inferior.



*Soporte angular de metal (J) en los cuatro esquinas de la silla, las más cercanas posible desde el borde inferior.

*Metal angle bracket (J) on all four corners of the chair, the closest possible from the bottom edge.

Peças Necessárias | Partes requeridas | Required Parts:

1	Encosto Estofado Respaldo tapizado Upholstered backrest	02
2	Assento Estofado Asiento tapizado Upholstered seat	02

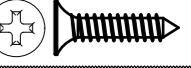
Ferragens | Herrajes | Hardware:

C		x06
H		x16
I		
K		

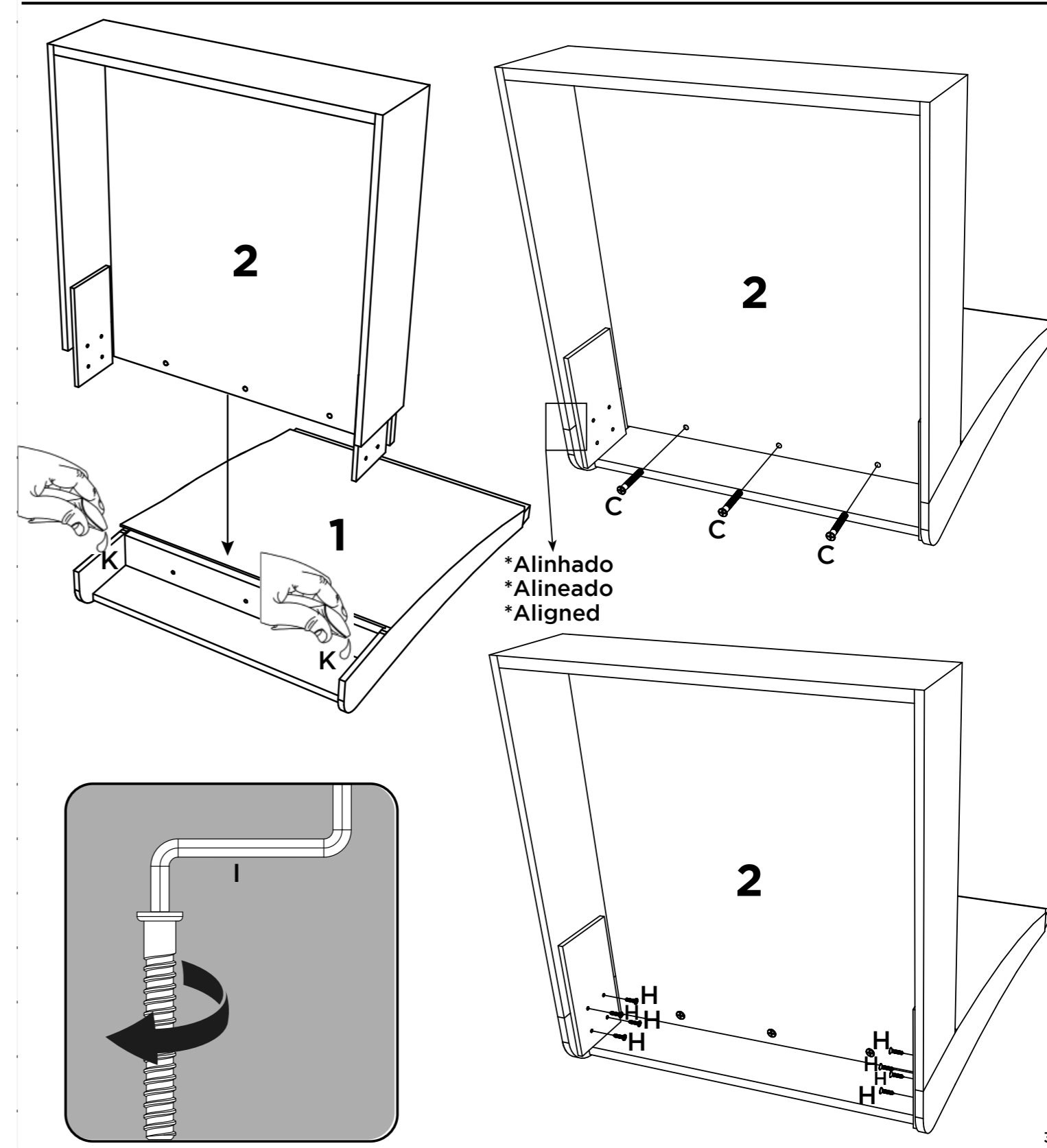

*Alinhado
*Alineado
*Aligned

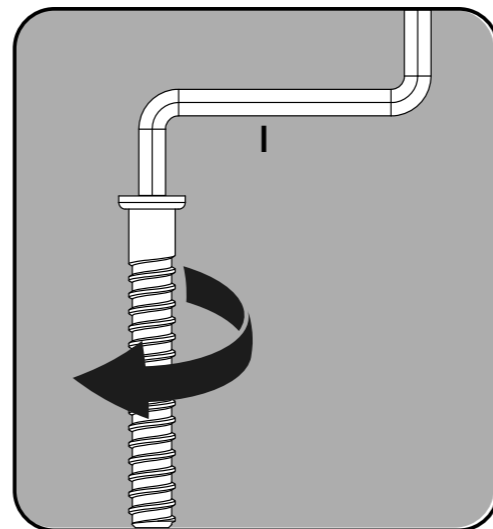



3

Peças Necessárias | Partes requeridas | Required Parts:

3	Pé Frontal Pie delantero Front foot	04
4	Pé Traseiro Pie trasero Back foot	04
5	Travessa Lateral Plato lateral Side Platter	04

Ferragens | Herrajes | Hardware:

A		x16
E		x16
I		

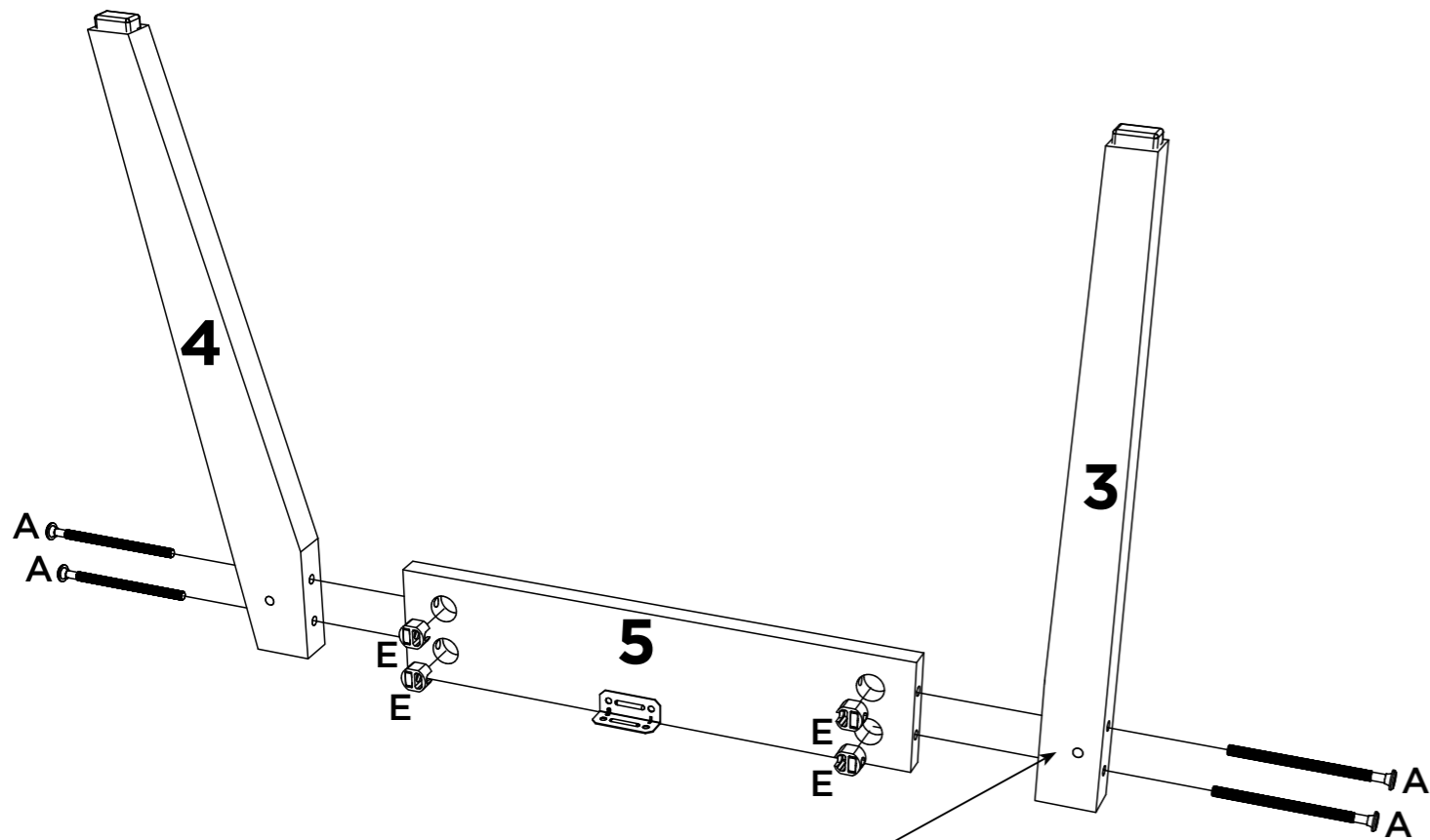

*Furação próxima a borda de fora do Pé.
 *Perforar cerca del borde exterior del pie.
 *Drilling close to the outside edge of the Foot.

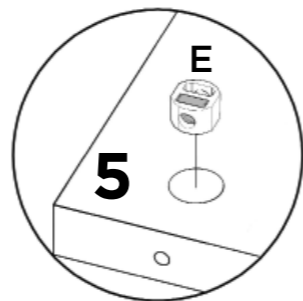
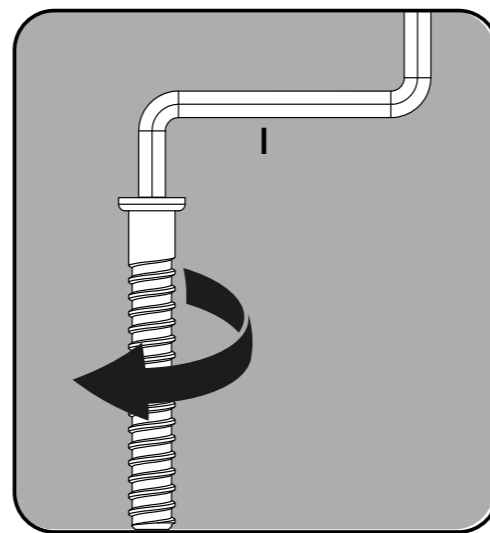



4

Peças Necessárias | Partes requeridas | Required Parts:

6	Travessa Plato Platter	04
---	----------------------------	----

Ferragens | Herrajes | Hardware:

B		x08
E		x08
I	