

# GR. FRANÇA 03 PTS CORRER

WARDROBE FRANCE 03 PTS CORRER  
ROPERO FRANCIA 03 PTS CORRER

## ESQUEMA DE MONTAGEM 946034

ASSEMBLING INSTRUCTIONS  
MANUAL DE ARMADO

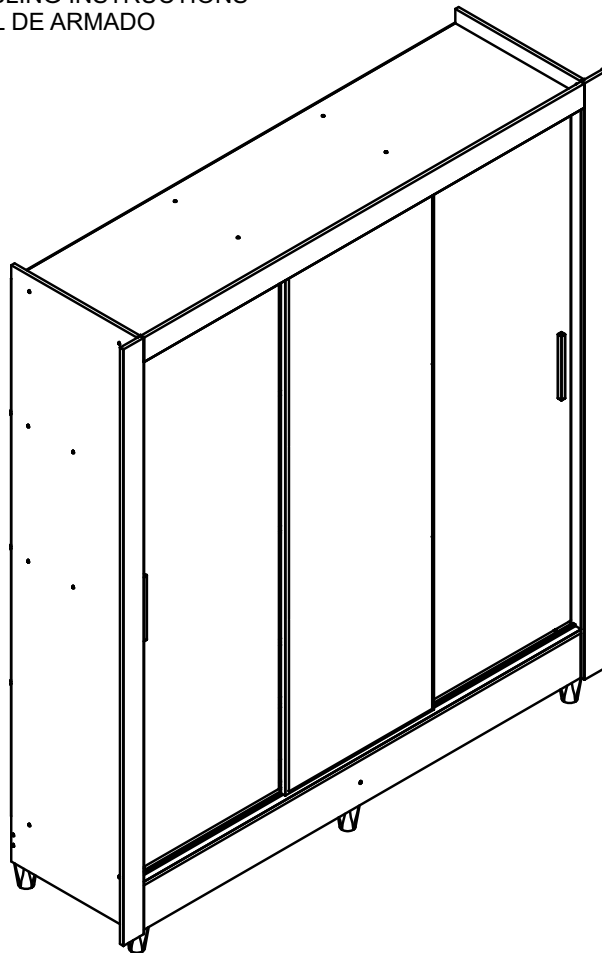

santos  
**Andirá**



ESCANEE O QR CODE  
OU CLIQUE AQUI PARA  
RESPONDER A PESQUISA



164266 • BRANCO/OFF



60 minutos  
60 minutes

[www.santosandira.com.br](http://www.santosandira.com.br)

## AVISO

**Para limpeza do seu móvel utilize flanela seca ou levemente umedecida, sem produtos químicos!**

## WARNING

*To clean your mobile use dry cloth or slightly moistened, no chemicals!*

## ADVERTENCIA

*Para limpiar su mueble use un paño seco o ligeramente humedecido, sin productos químicos!*



ISO 9001



ISO 14001



**Descarte os resíduos de forma seletiva!**

*Dispose of waste selectively!*

*¡Deseche los residuos de manera selectiva!*

**Em caso de produto com espelho siga as instruções abaixo**

*In the case of a product with a mirror, follow the instructions below*

*En el caso de un producto con espejo, siga las instrucciones a continuación*

**Cole os espelhos na porta e aguarde cerca de 01 hora para fazer a colocação da mesma no produto.**

*Attach the mirrors to the door and wait about 01 hour to place it on the product.*

*Coloque los espejos en la puerta y espere alrededor 01 hora para colocarlos sobre el producto.*



**RELAÇÃO DE PEÇAS**  
LIST OF PARTS • LISTA DE PARTES

DESCRIÇÃO DESCRIPTION DESCRIPCIÓN	VOLUME VOLUME VOLUMEM	NÚMERO NUMBER NÚMERO	DIMENSÃO DIMENSION DIMENSIÓN	QUANTIDADE QUANTITY CANTIDAD
VISTA SUPERIOR SUPERIOR FRONTAGE VISTA SUPERIOR	01	01	1569x075x012	01
FUNDO DE GAVETA DRAWER'S BOTTOM FONDO DEL CAJÓN	01	03	438x305x2,5	02
CABIDEIRO FRIZADO FRIZZED HANGER PERCHERO FRIZADO	01	04	506mm	03
PERFIL PLASTICO PLASTIC PROFILE PERFIL PLÁSTICO	01	05	1590mm	03
LAT. DE GAV. SIDE DRAWER LAT. DEL CAJÓN	01	9681	300x101x012	04
LAT. EXT. ESQUERDA LEFT EXTERNAL SIDE LAT. EXT. IZQUIERDA	01	9708	1840x448x012	01
LAT. INTERNA ESQUERDA LEFT INTERNAL SIDE LAT. INTERNA IZQUIERDA	01	9710	1634x325x012	01
TAMPO GAVETA DRAWER'S COVER TAPA DEL CAJÓN	01	9716	515x325x012	01
TAMPO COVER TAPA	01	9717	515x280x012	02
BASE MALEIRO BASE FOR LUGGAGE RACK BASE DEL PORTAEQUIPAJES	01	9718	515x280x012	02
FRENTE DE GAV. DRAWER'S FRONT FRENTE DEL CAJÓN	01	9719	457x160x012	02
RODAPÉ CALÇO WEDGE BASEBOARD ZÓCALO CALZO	01	9720	422x138x012	01
TRASEIRO DE GAVETA DRAWER'S BACKBOARD TRASERO DE CAJÓN	01	9721	416x090x012	02
LAT. EXT. DIREITA RIGHT EXTERNAL SIDE LATERAL EXTERNA DERECHA	01	9900	1840x448x012	01
VISTA LATERAL SIDE VIEW VISTA LATERAL	01	9901	1840x073x012	02
LAT. INTERNA DIREITA RIGHT INTERNAL SIDE LAT. INTERNA DERECHA	01	9902	1634x325x12	01
BASE INFERIOR BASE FOR LUGGAGE RACK BASE DEL PORTAEQUIPAJES	01	9903	1569x448x012	01
CHAPEU WARDROBE'S TOP TAPA SUPERIOR	01	9904	1569x448x012	01
RODAPÉ FRONTAL FRONT BASEBOARD ZÓCALO FRONTAL	01	9905	1569x138x012	01
RODAPÉ TRASEIRO BACK BASEBOARD ZÓCALO TRAS.	01	9906	1569x138x012	01

**Ps:** Peças e Complementos que não contém processo de furação não são enumeradas.  
Parts and Accessories that do not contain drilling process and are not listed.  
Piezas y Accesorios que no contienen procesos de perforación y que no numerados.

05

**RELAÇÃO DE PEÇAS**  
LIST OF PARTS • LISTA DE PARTES

DESCRIÇÃO DESCRIPTION DESCRIPCIÓN	VOLUME VOLUME VOLUMEM	NÚMERO NUMBER NÚMERO	DIMENSÃO DIMENSION DIMENSIÓN	QUANTIDADE QUANTITY CANTIDAD
TRASEIRO G.R WARDROBE'S BACKBOARD COSTADO DEL ROPERO	02	02	1590x410x2,5	04
PORTA DOOR PUERTA	02	9899	1615x530x015	02
PORTA DOOR PUERTA	02	9907	1615x530x015	01

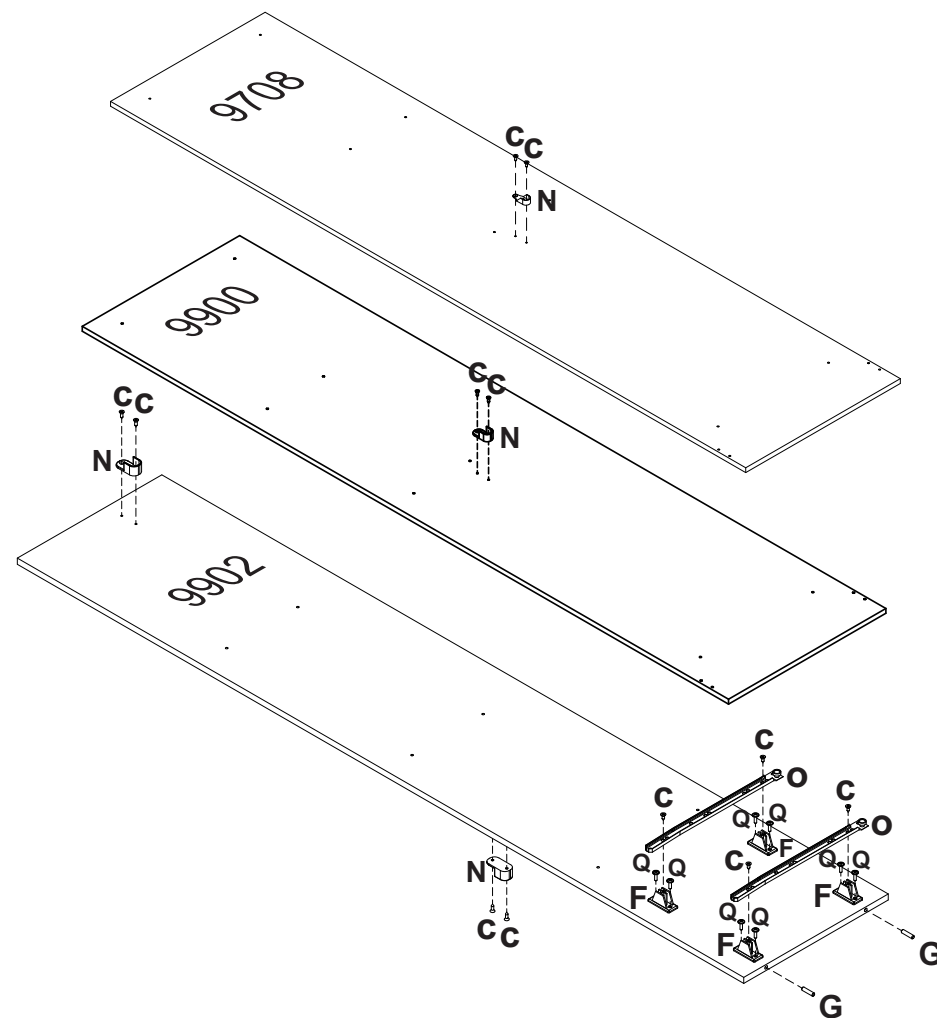

06

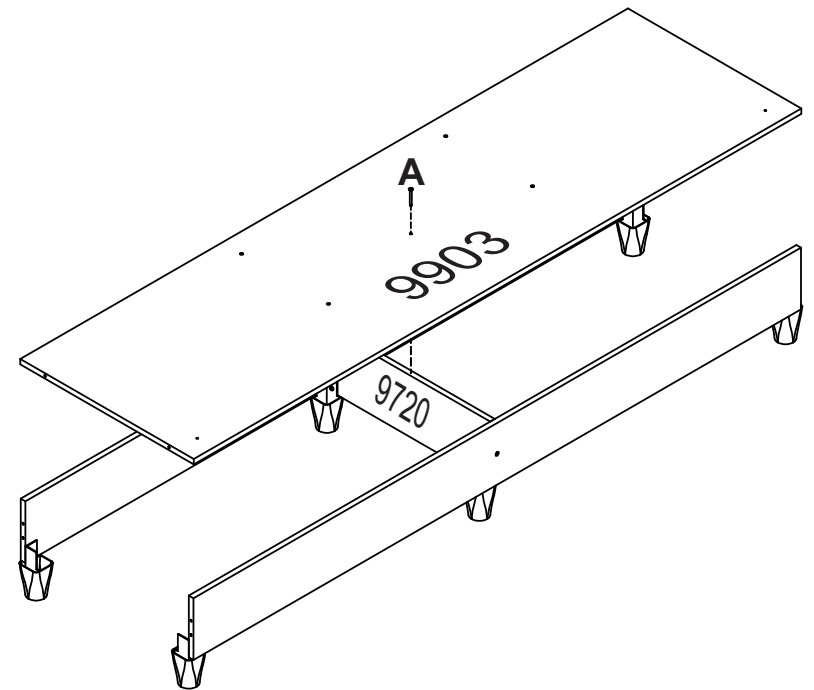
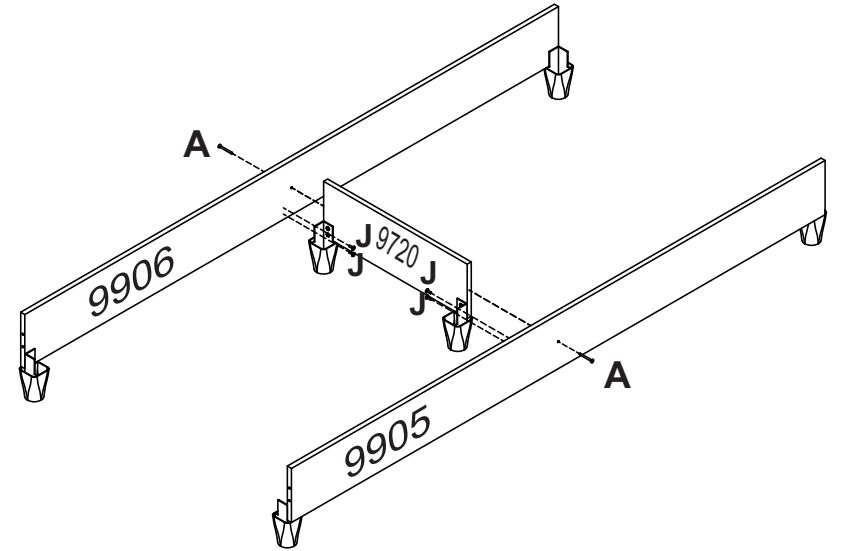
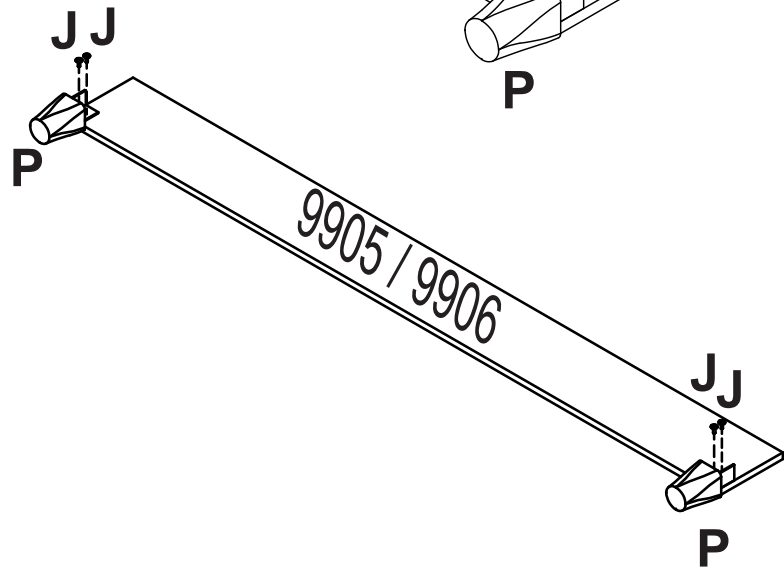
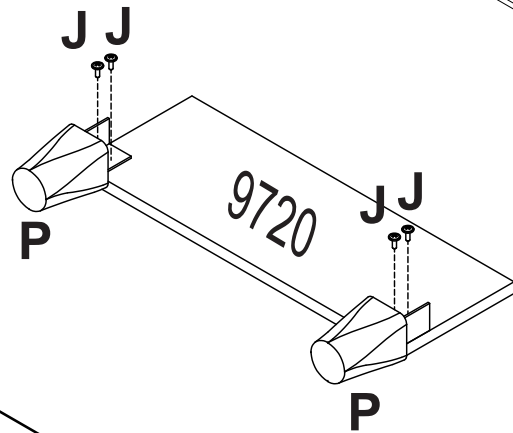
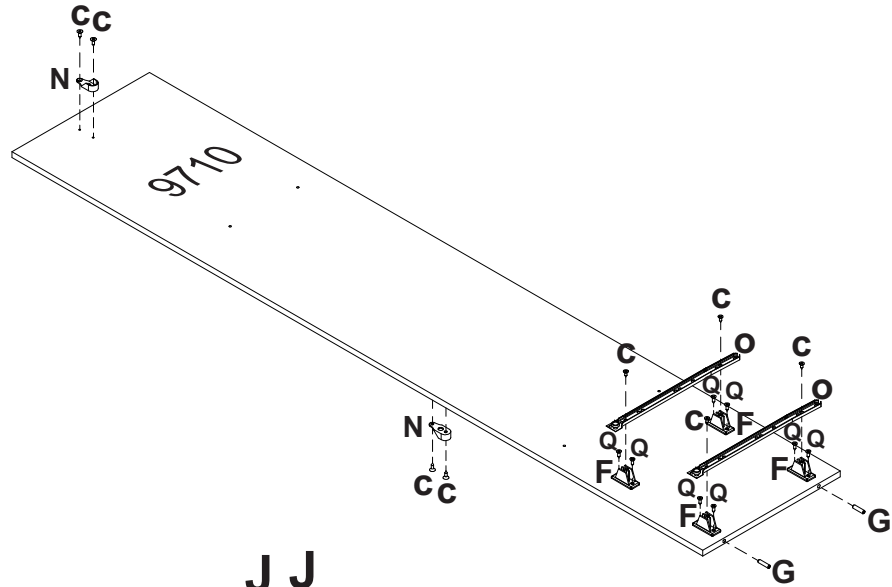

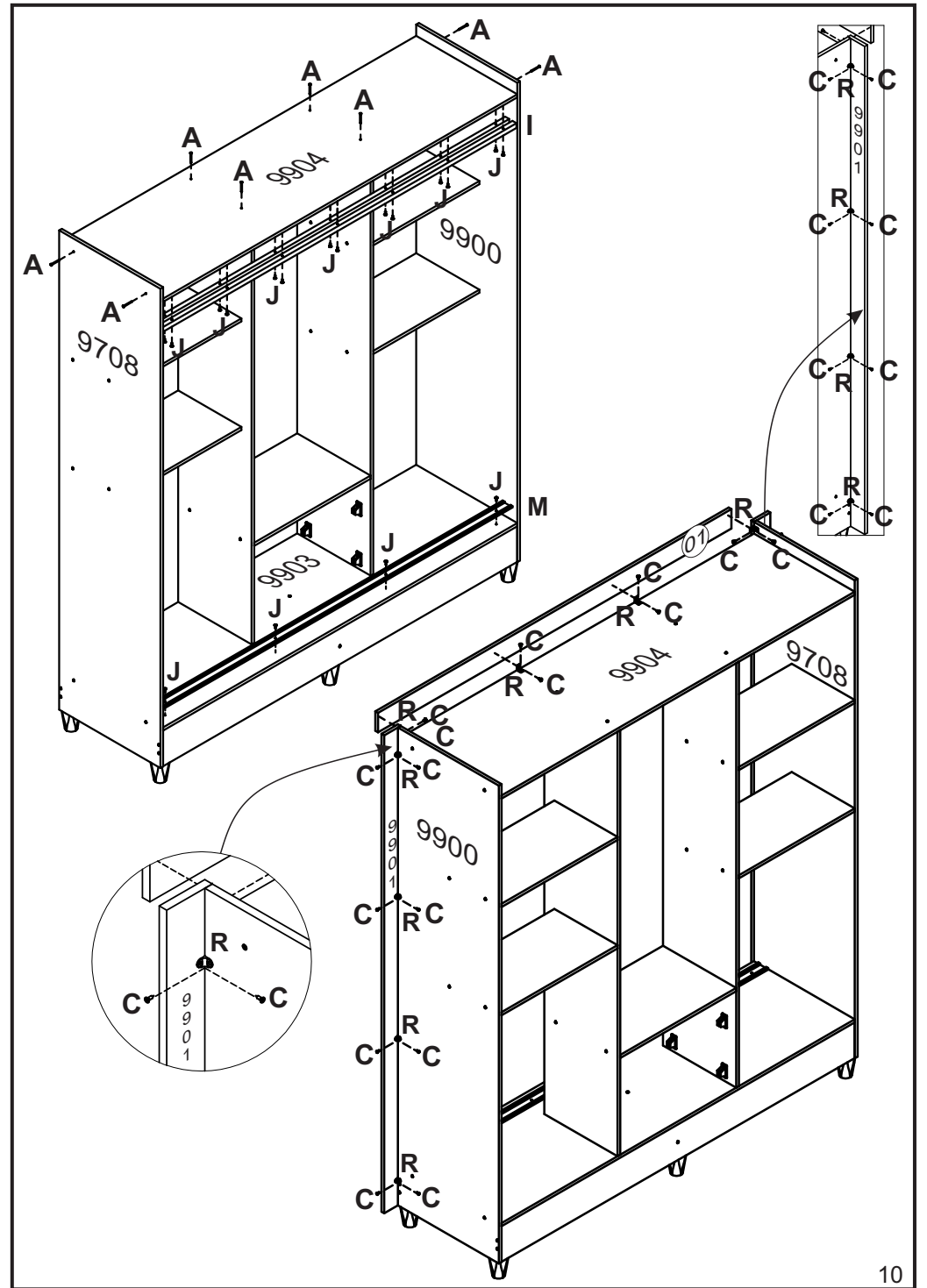
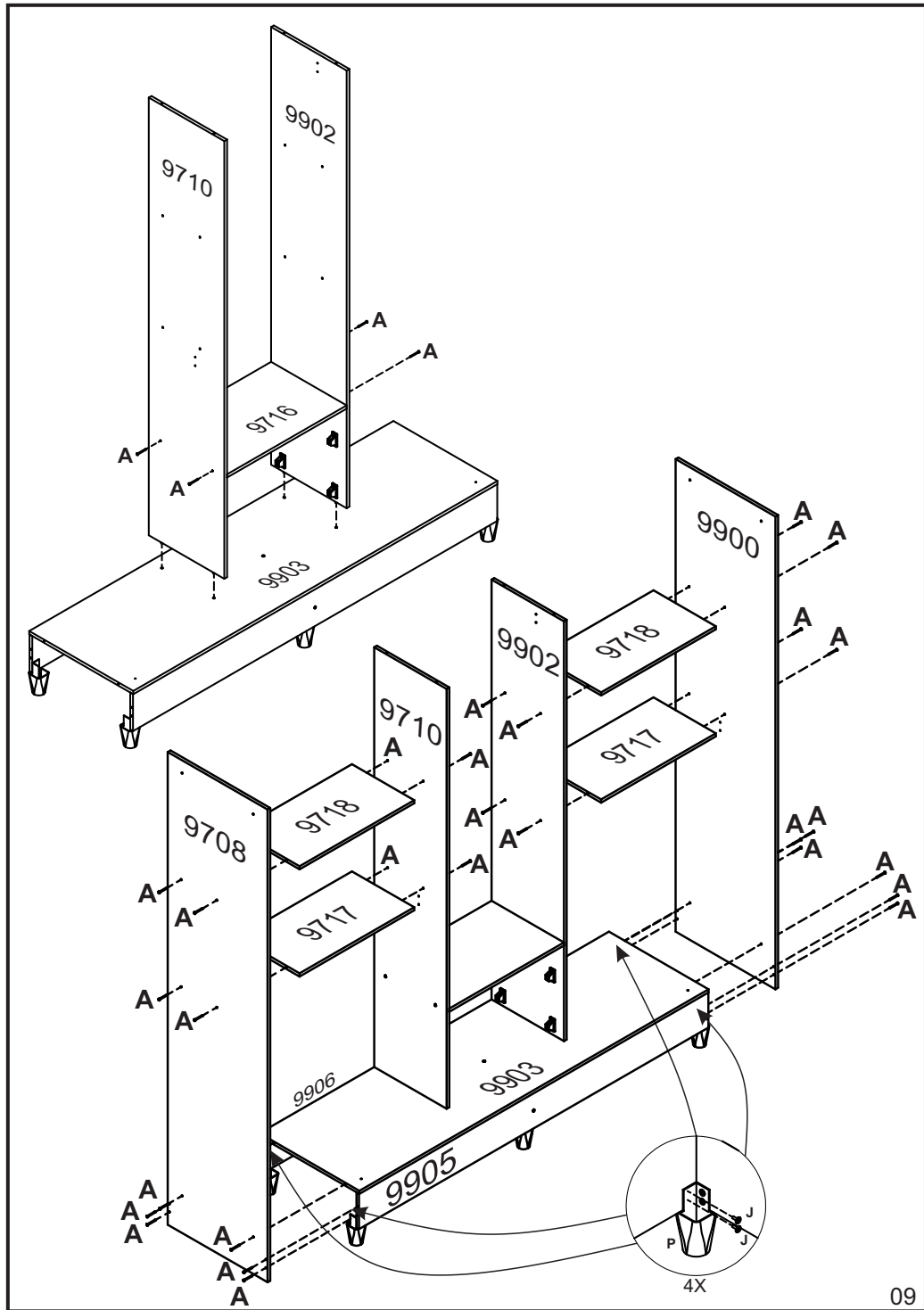

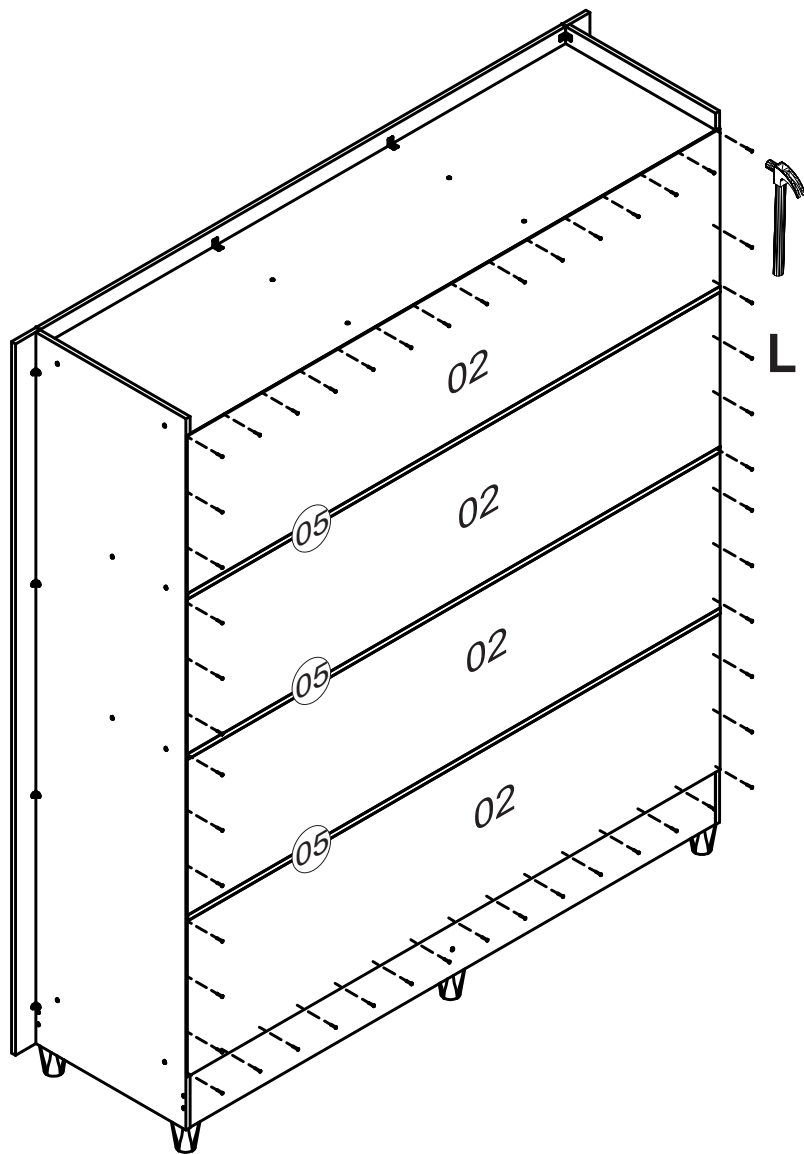

“Fixar os pregos a (100mm) de distância de um para outro”  
 “Fix the nails to (100mm) away from each other”  
 “Fijar los clavos a (100mm) de distancia de uno a otro”

11

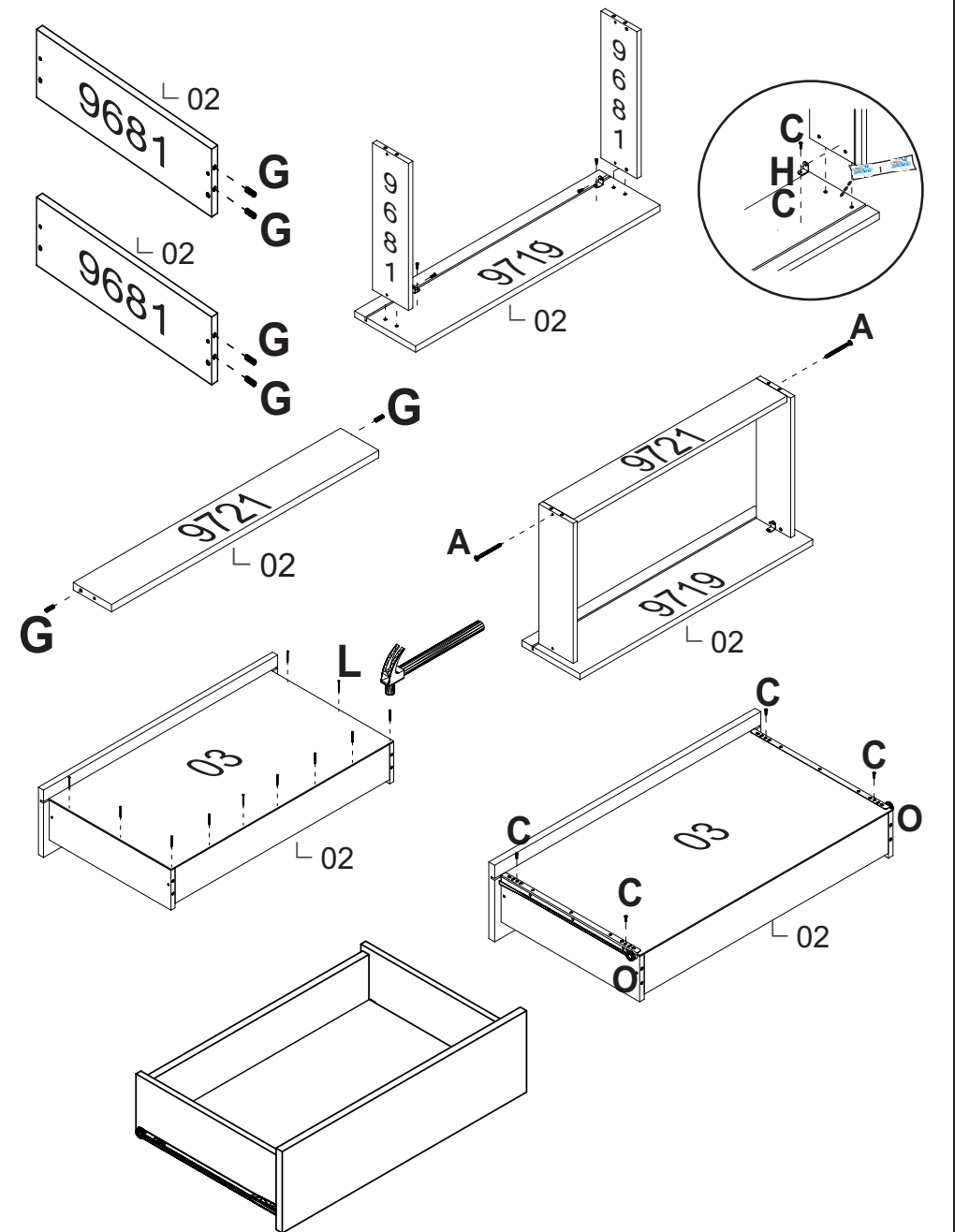

“Usar cola em todas as cavilhas”  
 “Use glue on all wood pegs”  
 “Utilizar cola en todos los tarugos de madera”

12

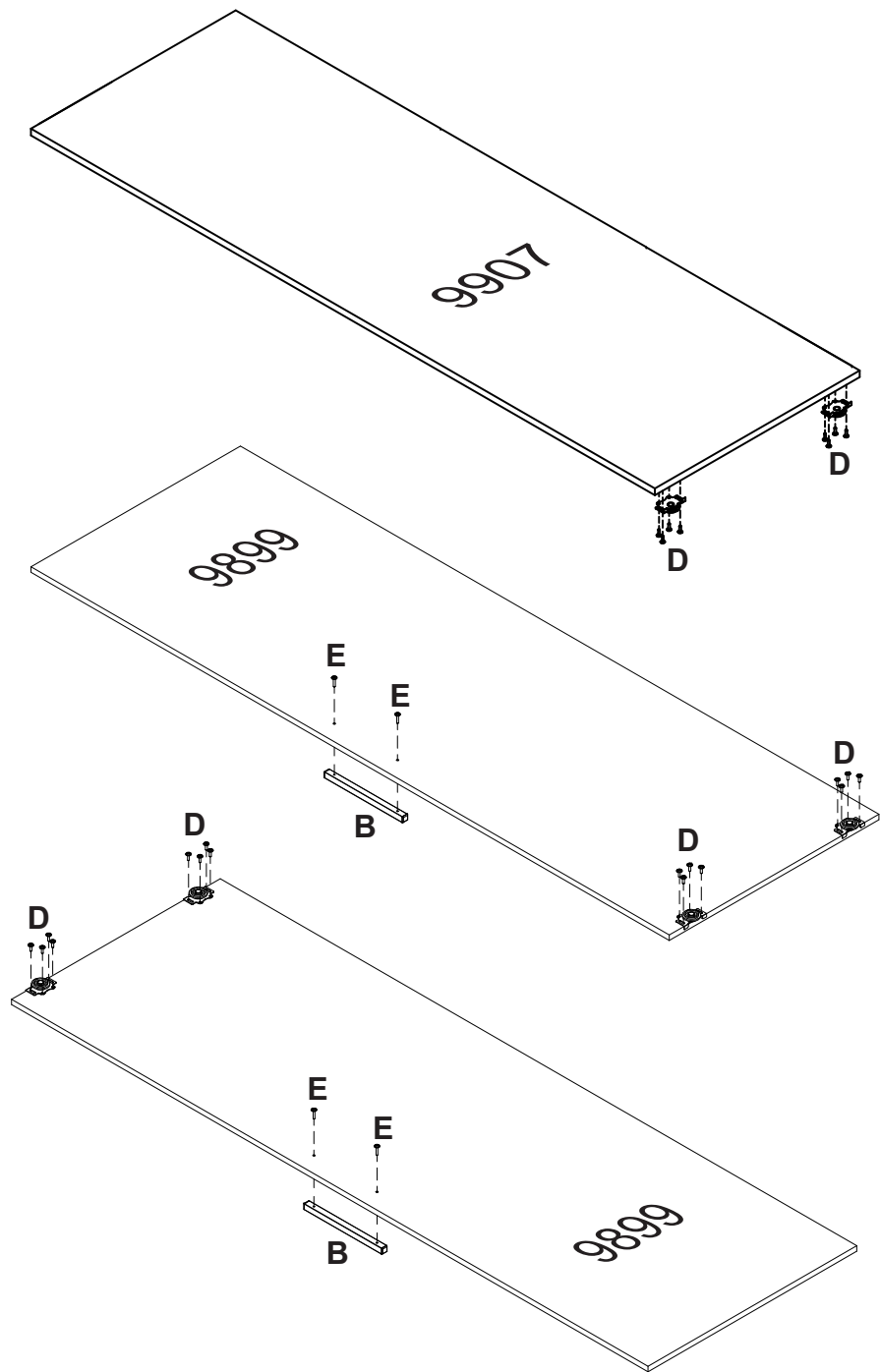

**MEDIDA DO PRODUTO MONTADO**  
 MEASURE OF THE ASSEMBLED PRODUCT  
 MEDIDA DEL PRODUCTO ENSAMBLADO

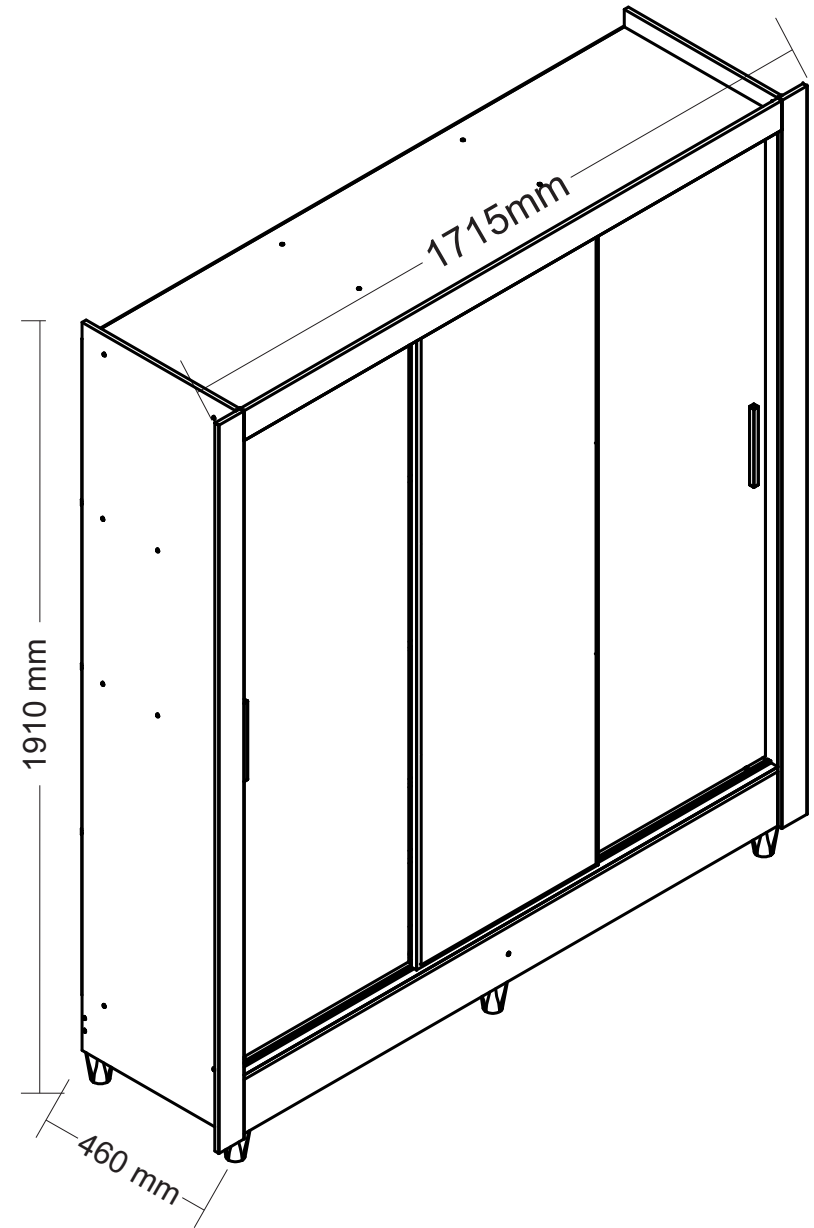

☎ +55 (43)3538-8300