

**GAVETAS: RACK 3 GAVETAS 2,20m**  
**DRAWERS: 3 DRAWER RACK 2,20m**  
**CAJONES: ESTANTE DE 3 CAJONES 2,20m**

**FKD-104** - VOL.01

09/04/25 Rev.00

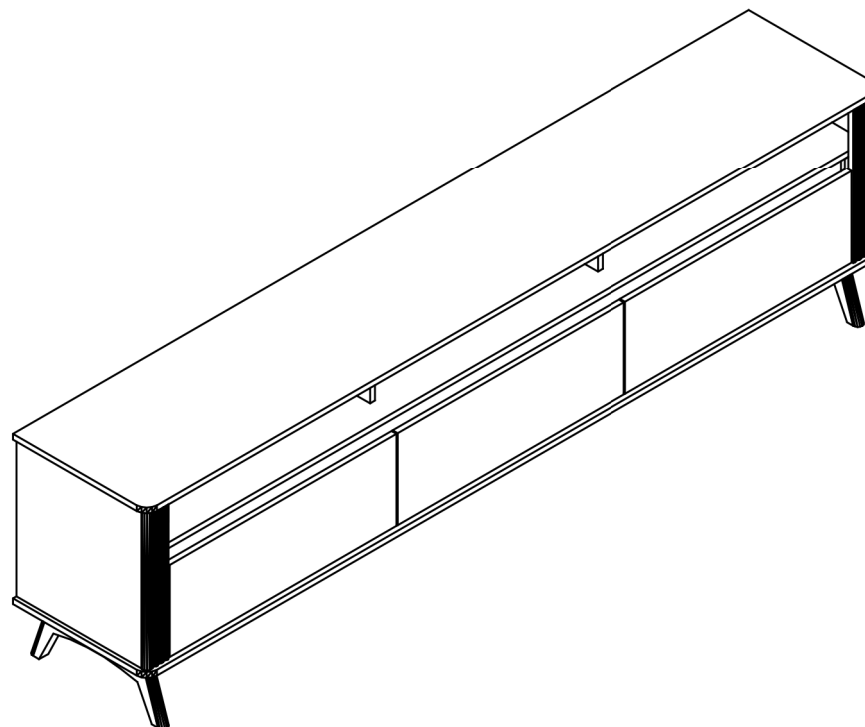

Para facilitar o processo de montagem, utilizar o manual volume 1 para iniciar a montagem do rack 3 gavetas 2,20m. Somente após, dar sequência ao manual volume 2. To facilitate the assembly process, use manual volume 1 to begin assembling the 2.20m 3-drawer rack. Only then proceed to manual volume 2. Para facilitar el proceso de montaje, utilice el manual del volumen 1 para iniciar el montaje del rack de 3 cajones de 2,20m. Sólo entonces, continúe con el volumen manual 2.



**Atenção:** Não empurre ou arraste o produto, pois isso pode causar danos à sua estrutura e funcionamento.

**Attention:** Do not push or drag the product, as this may cause damage to its structure and functioning.

**Atención:** No empujar ni arrastrar el producto, ya que esto puede provocar daños en su estructura y funcionamiento.



- Antes de iniciar a montagem, verifique se você recebeu todos os componentes e peças do produto.
- Before starting assembly, make sure you have received all the components and parts for the product.
- Antes de comenzar el montaje, asegúrese de haber recibido todos los componentes y piezas del producto
  
- Para montagem, sugerimos contratação de um profissional.
- For assembly, we suggest hiring a professional.
- Para el montaje, sugerimos contratar a un profesional.

## INSTRUÇÕES DE MONTAGEM ASSEMBLY INSTRUCTIONS INSTRUCCIONES DE MONTAJE



Pessoas necessárias.  
Necessary people.  
Gente necesaria.



Grau de dificuldade médio.  
Medium difficulty level.  
Nivel de dificultad medio.



Evitar batidas e objetos cortantes.  
Avoid bumps and sharp objects.  
Evitar golpes y objetos afilados.



Pano levemente umedecido com água,  
seguido de pano seco.  
Cloth slightly dampened with water by a  
dry cloth.  
Paño ligeramente humedecido con agua,  
seguido de un paño seco.

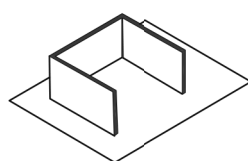

Deve-se fazer a montagem do  
módulo em cima de uma superfície  
macia. **Dica:** Usar a caixa.  
The module must be mounted on a  
soft surface. **Tip:** Use the box.  
El módulo debe montarse sobre una  
superficie blanda. **Consejo:** Usa la caja.



Não utilizar químicos ou abrasivos na  
limpeza.  
Do not use chemicals or abrasives when  
cleaning.  
No utilice productos químicos ni abrasivos  
al limpiar.

## FERRAMENTAS NECESSÁRIAS (não fornecidas) REQUIRED TOOLS (not provided) HERRAMIENTAS REQUERIDAS (no provisto)



Chave Philips  
Philips Screwdriver  
Destornillador Philips



Parafusadeira  
Screwdriver  
Destornillador



Trena  
Tape  
Cinta



Martelo  
Hammer  
Martillo

## Componentes das gavetas

Drawer components

Componentes del cajón



A - Cavilha 8x30 (12x)  
A - Dowel 8x30 (12x)  
A - Clavija 8x30 (12x)

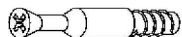

B - Minifix (12x)  
B - Minifix (12x)  
B - Miniarreglo (12x)



C - Tambor (12x)  
C - Drum (12x)  
C - Tambor (12x)



D - Tapa furo adesivo (12x)  
D - Adhesive hole cover (12x)  
D - Tapa del agujero adhesivo (12x)



F9 - Parafuso Ø5x35 (6x)  
F9 - Screw Ø5x35 (6x)  
F9 - Tornillo Ø5x35 (6x)



F14 - Parafuso Ø4x16 (12x)  
F14 - Screw Ø4x16 (12x)  
F14 - Tornillo Ø4x16 (12x)



G - Cola (3x)  
G - Paste (3x)  
G - Pasta (3x)



R1 - Chave Allen (1x)  
R1 - Allen key (1x)  
R1 - llave allen (1x)

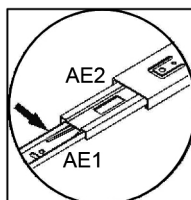

AE - Trilho telescópico gavetas (3 pares)  
AE - Telescopic drawer rail (3 pairs)  
AE - Riel telescópico para cajones (3 pares)

**É necessário desmontar os trilhos telescópicos, abaixando a trava conforme detalhe ao lado. Após separação: o AE1 será utilizado no passo 4 vol. 1 e, o AE2 na pré-montagem do módulo peças 90, 91 e 93 vol. 2.** It is necessary to disassemble the telescopic rails, lowering the lock as shown in detail on the side. After separation: AE1 will be used in step 4 vol. 1 and AE2 in the pre-assembly of module parts 90, 91 and 93 vol. 2. Es necesario desmontar los raíles telescópicos, bajando la cerradura como se muestra en el detalle lateral. Después de la separación: AE1 se utilizará en el paso 4 vol. 1 y, el AE2 en el premontaje de las piezas del módulo 90, 91 y 93 vol. 2.

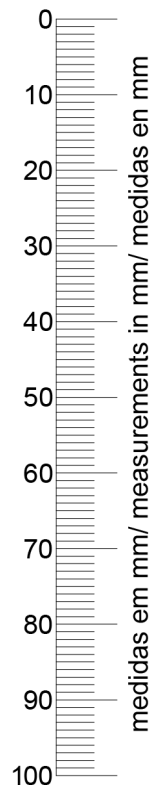

## Partes das gavetas

Parts of drawers

Partes de cajones

- 50 Lateral esquerda gaveta (3x)  
Left side drawer (3x) /  
Cajón lateral izquierdo (3x)
- 51 Lateral direita gaveta (3x)  
Right side drawer (3x) /  
Cajón lateral derecho (3x)
- 52 Fundo gaveta (3x)  
Drawer bottom (3x) /  
Fondo del cajón (3x)
- 53 Base gaveta (3x)  
Drawer base (3x) /  
Base del cajón (3x)
- 54 Frente gaveta (3x)  
Drawer front (3x) /  
Frente del cajón (3x)

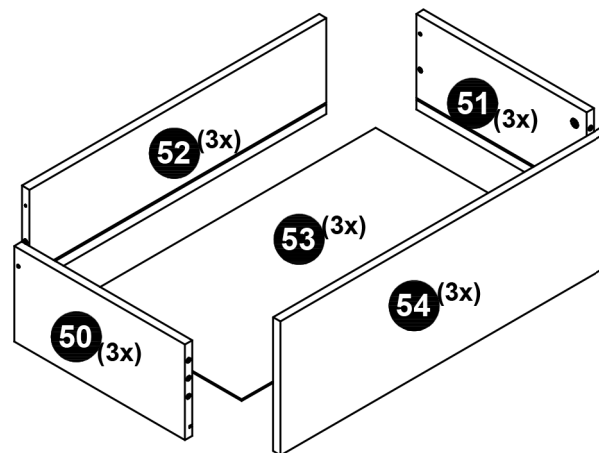

**Pré-montagem das gavetas**  
Pre-assembly of the drawers  
Premontaje de los cajones

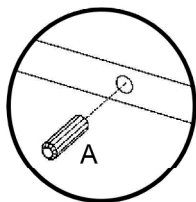
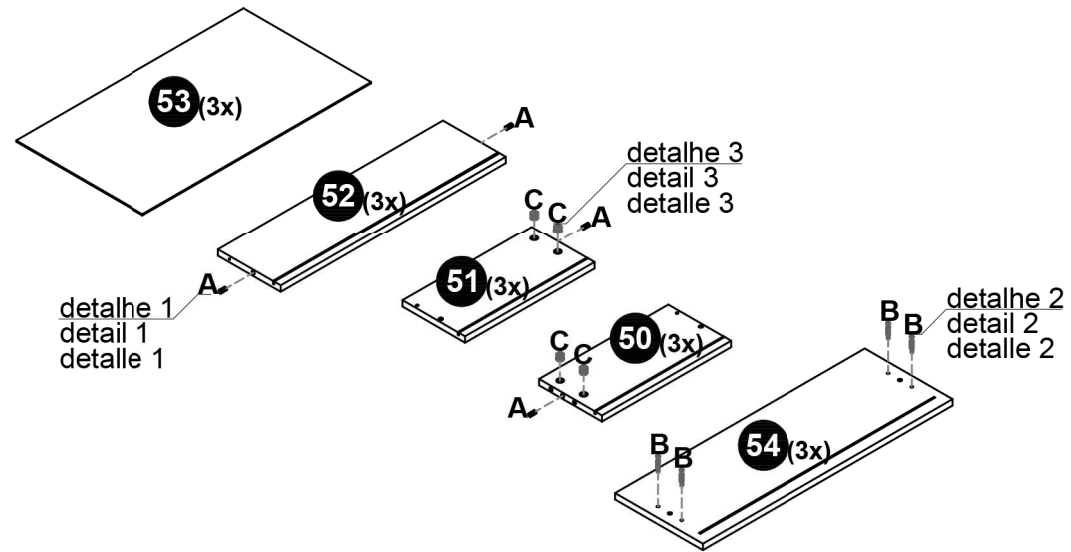

**detalhe 1**  
detail 1  
detalle 1

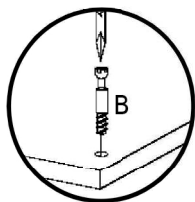

**detalhe 2**  
detail 2  
detalle 2

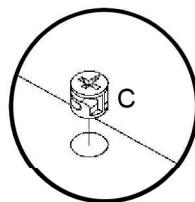

**detalhe 3**  
detail 3  
detalle 3

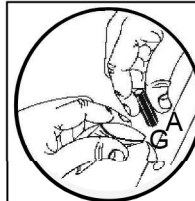

**Utilizar cola nas cavilhas da frente da gaveta.** Use glue on the drawer front dowels. Use pegamento en las clavijas del frente del cajón.

## Montagem das gavetas

Assembling the drawers

Montaje de los cajones

1



R1 - Chave Allen (1x) F9 - Parafuso Ø5x35 (6x)  
R1 - Allen key (1x) F9 - Screw Ø5x35 (6x)  
R1 - llave allen (1x) F9 - Tornillo Ø5x35 (6x)

### GAVETA DRAWER CAJÓN 3X

Lateral dir. gaveta + lateral esq. gaveta + fundo gaveta

Right side drawer + left side drawer + drawer bottom

Cajón lateral derecho + cajón lateral izquierdo + fondo del cajón

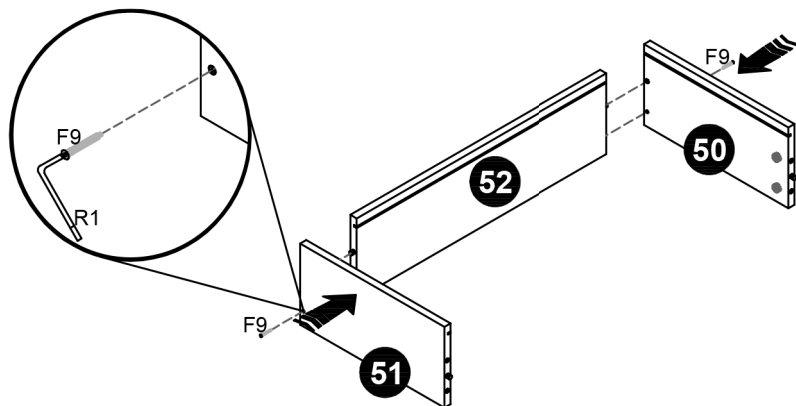

2

### GAVETA DRAWER CAJÓN 3X

Etapa concluída no passo 1 + base gaveta

Step completed in step 1 + drawer base

Paso completado en el paso 1 + base del cajón

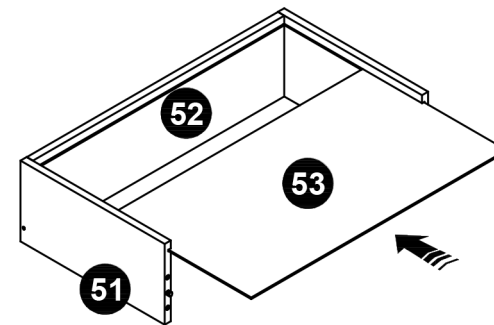

Após realizar o passo 2, conferir na diagonal as metragens da base da gaveta, elas devem ser iguais. After completing step 2, check the diagonal measurements of the drawer base; they should be the same. Luego de realizar el paso 2, verifica las dimensiones de la base del cajón en diagonal, deben ser iguales.

**3** 

C - Tambor (12x) D - Tapa furo adesivo (12x)  
C - Drum (12x) D - Adhesive hole cover (12x)  
C - Tambor (12x) D - Tapa del agujero adhesivo (12x)

### GAVETA DRAWER CAJÓN 3X

**Etapa concluída no passo 2 + frente gaveta**

Step completed in step 2 + drawer front

Paso completado en el paso 2 + frente del cajón

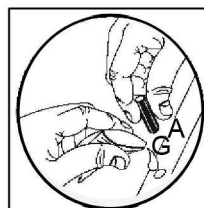
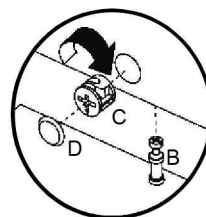
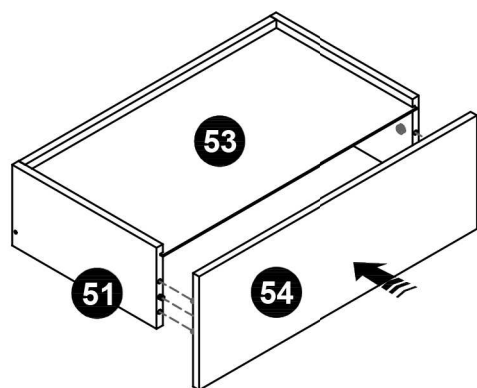

Utilizar cola nas cavilhas da frente da gaveta. Use glue on the drawer front dowels. Use pegamento en las clavijas del frente del cajón.

**4** 

AE - Trilho telescópico (6x) F14 - Parafuso Ø4x16 (12x)  
AE - Telescopic rail (6x) F14 - Screw Ø4x16 (12x)  
AE - Carril telescópico (6x) F14 - Tornillo Ø4x16 (12x)

### GAVETA DRAWER CAJÓN 3X

**Etapa concluída no passo 3 + fixação do trilho telescópico**

Step 3 completed + fixing the telescopic rail

Paso 3 completado + fijación del riel telescópico

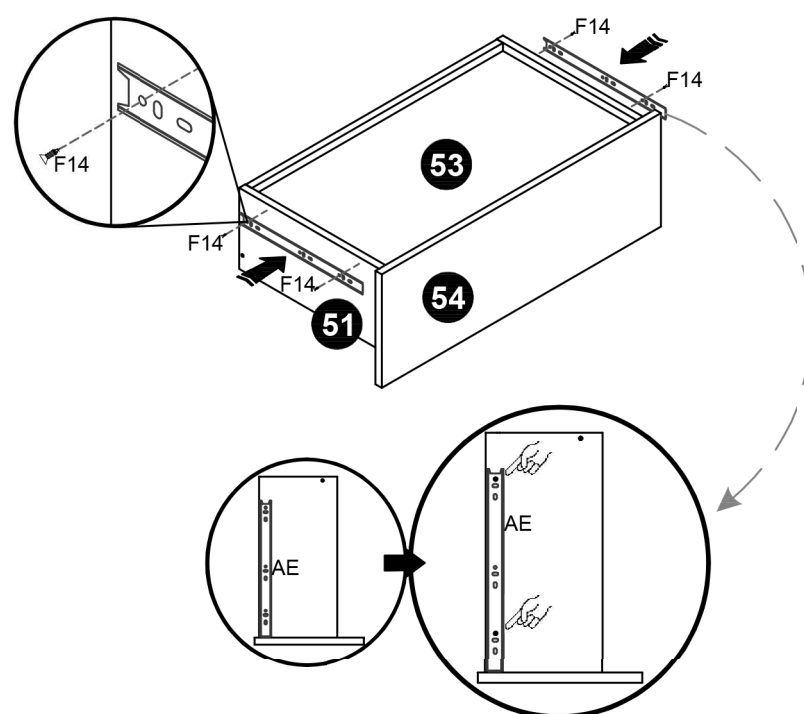

Alinhar a corredeira na parte inferior da lateral da gaveta e parafusar. Align the slide at the bottom of the drawer side and screw it in. Alinee la corredera en la parte inferior del lateral del cajón y atorníllela.

Ver página 3: componentes das gavetas. O AE1 será utilizado no passo 4 vol. 1 e, o AE2 na pré-montagem do módulo peças 90, 91 e 93 vol. 2. See page 3: drawer components. AE1 will be used in step 4 vol. 1 and AE2 in the pre-assembly of module parts 90, 91 and 93 vol. 2. Ver página 3: Componentes del cajón. AE1 se utilizará en el paso 4 vol. 1 y, el AE2 en el premontaje de las piezas del módulo 90, 91 y 93 vol. 2.

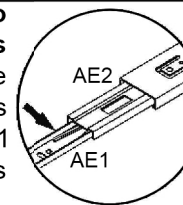

5

O processo de montagem do módulo, juntamente com a fixação dos trilhos telescópicos nas laterais internas direita e esquerda, e nas divisórias 355x271, são apresentados no volume 2. The module assembly process, together with the fixing of the telescopic rails on the right and left internal sides, and on the 355x271 dividers, are presented in volume 2. El proceso de montaje del módulo, junto con la fijación de los carriles telescópicos en los lados internos derecho e izquierdo, y en los divisores de 355x271, se presentan en el volumen 2.

**Encaixe das gavetas no módulo**  
Fitting the drawers into the module  
Colocación de los cajones en el módulo

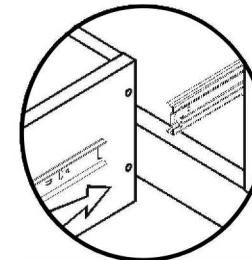
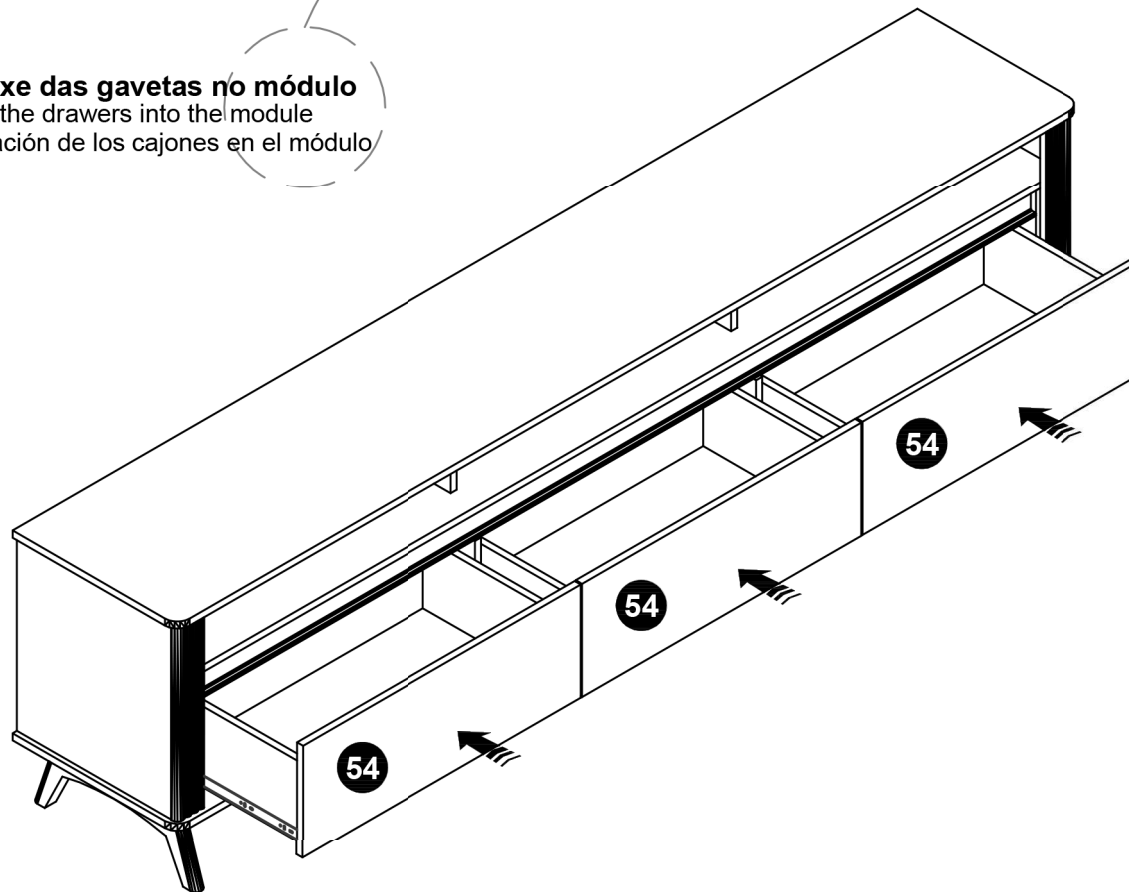

**Como encaixar as gavetas.** How to fit the drawers. Cómo encajar los cajones.

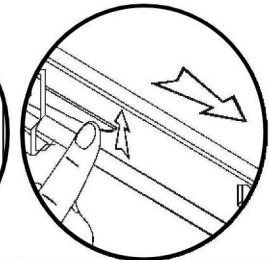

**Como tirar as gavetas.** How to remove the drawers. Cómo quitar los cajones.

**6** Finalizado  
Finished  
Finalizado

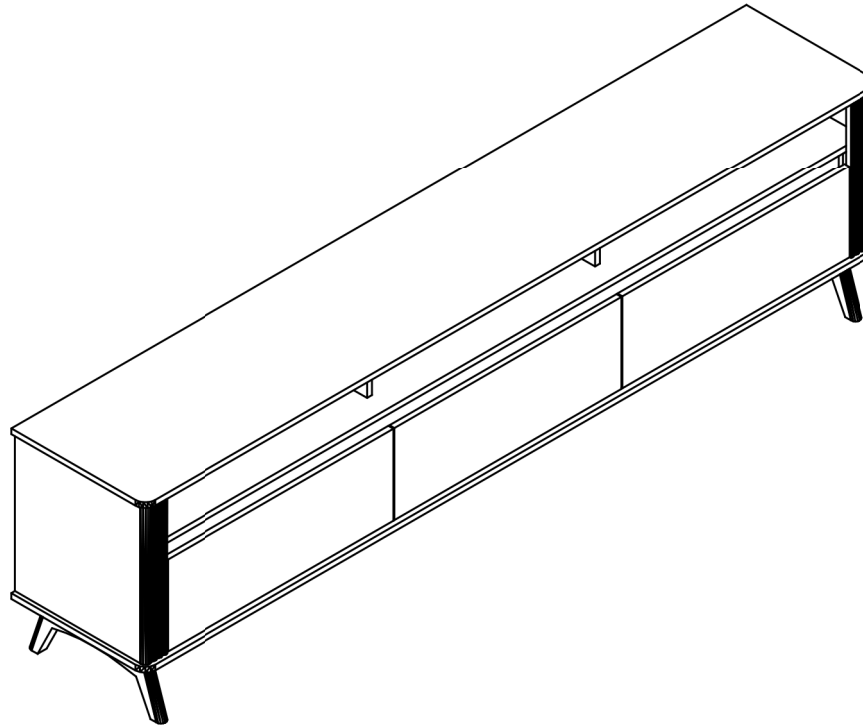

Tampo: 15kg  
Top: 15kg  
Arriba: 15kg



Prateleira: 5kg  
Shelf: 5kg  
Estante: 5kg



Gavetas: 5kg  
Drawers: 5kg  
Calzoncillos: 5kg



Atenção: Não empurre ou arraste o produto, pois isso pode causar danos à sua estrutura e funcionamento.

Attention: Do not push or drag the product, as this may cause damage to its structure and functioning.

Atención: No empujar ni arrastrar el producto, ya que esto puede provocar daños en su estructura y funcionamiento.

Ferimentos por esmagamentos graves ou fatais podem ocorrer com a queda do móvel.

Para reduzir o risco de tombamento de móveis:

- SEMPRE instale o sistema de antitombamento fornecido.
- NUNCA instale uma TV sobre esse produto.
- NUNCA permita que crianças fiquem em pé, subam ou se pendurem em gavetas, portas ou prateleiras.
- NUNCA abra mais de uma gaveta ao mesmo tempo.
- Coloque os objetos mais pesados nas gavetas inferiores.



Informação permanente.  
Não remova!

Serious or fatal crushing injuries can occur from the tipover.

To reduce the risk of furniture tipover:

- ALWAYS install tipover restraint provided.
- NEVER put a TV on this product.
- NEVER allow children to stand, climb or hang on drawers, doors or shelves.
- NEVER open more than one drawer at a time.
- Place heaviest items in the lowest drawers.



This is a permanent label.  
Do not remove!

Riesgo de aplastamiento graves o fatales en caso de caídas de los muebles.

Para reducir el riesgo de que los muebles se vuelquen:

- Instale siempre el sistema antivuelco proporcionado.
- NUNCA instale una TELE en este producto.
- NUNCA permita que los niños se paren, trepen o cuelguen de cajones, puertas o estantes.
- NUNCA abra más de un cajón al mismo tiempo.
- Coloque los objetos más pesados en los cajones inferiores.



Permanent information.  
¡No lo quites!