

**INSTRUCCIONES DE ARMADO / ASSEMBLY INSTRUCTIONS**  
**COMODA 3 CAJONES BASIC CLAY / BASIC CLAY 3-DRAWER CHEST OF DRAWERS**



LOT N°

**RTA**<sup>®</sup>  
m u e b l e s

Tel: (602) 695 9581 / 695 91 81 | EXT 118  
La Nueva Estancia, Yumbo - Valle del Cauca - Colombia  
[www.rta.com.co](http://www.rta.com.co)

# ¡ATENCIÓN! / ATTENTION!

En las próximas páginas está el contenido de las piezas y herrajes del mueble. Asegúrate de que la cantidad de herrajes y piezas que hay en la caja sea la correcta y todo esté en buen estado. Ya que cuando el mueble esté armado no podrás realizar ninguna reposición.

On the next pages is the content of the pieces and hardware of the furniture. Make sure the number of hardware and parts in the box is correct and everything is in good condition. When the furniture is assembled you will not be able to make any replacement

## Recomendaciones Importantes / Key Recommendations

- Ensamble el mueble entre dos personas. / Assemble the cabinet between two people.
- Ensamble el mueble sobre una superficie plana y lisa, preferiblemente sobre un tapete o el cartón de la caja. / Assemble the cabinet on a flat smooth surface, preferably on a carpeted floor or the box carton.
- Se recomienda utilizar un destornillador eléctrico para facilitar el ensamble / It is recommended to use an electric screwdriver to facilitate assembly.

## Herramientas Necesarias / Required Tools



Destornillador de estrella  
Phillips Head  
Screwdriver



Destornillador de pala  
Flat Head  
Screwdriver

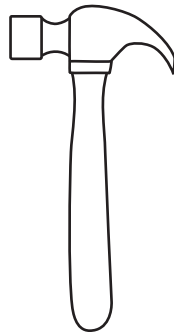

Martillo  
Hammer

## Herrajes Básicos / Basic Hardware

Aplica estas instrucciones cada vez que vayas a utilizar uno de estos herrajes durante el armado. / Apply these instructions everytime you're using one of these connectors during the assembly.

### Tarugos / Wood Dowels

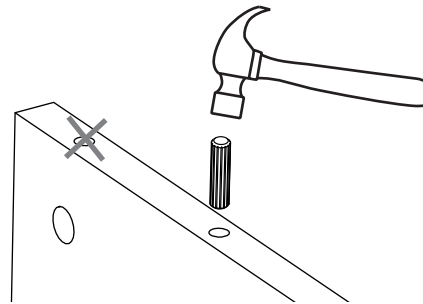

1. Inserta el tarugo en la perforación indicada y golpéalo suavemente hasta que llegue hasta el final de la perforación. / Put in the dowel inside the indicated hole and softly hit it until it's fully inside.
2. Verifica que NO se inserte el tarugo en la perforación de la caja minifix. / Verify that the dowel is NOT inserted into the perforation of the minifix cam.







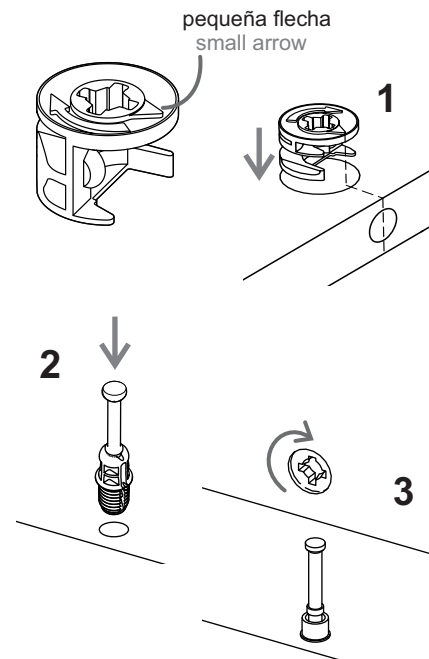





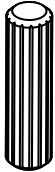
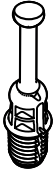

Para más información  
escanea AQUÍ  
Scan for more info

### Minifix y Pernos / Minifix Cam & Spreading Bolt

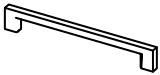

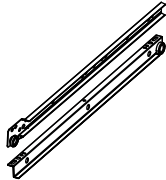
1. La caja minifix tiene una pequeña flecha en su parte superior, se debe insertar las cajas minifix con la flecha apuntando hacia la perforación que hay en el borde de la pieza. / The Minifix cam has a little arrow on its upper surface you should insert these cams with the little arrow pointing towards the drilling on the panel's edge.
2. Se debe insertar el perno con la parte plástica hacia abajo. / The spreading bolt should be put with the black plastic part facing down edge.
3. Luego de unir las piezas, se deben girar 180° las cajas minifix con un destornillador de estrella para ajustar y asegurar el ensamble. / After joining two panels together you should turn the cams 180° with a phillips head screwdriver to adjust and secure the joint.

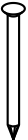
## Herrajes / Hardware

			
Tarugo / Wood dowel	Perno Minifix / Spreading Bolt	Caja Minifix / Minifix Cam	Tapa Minifix / Cover Caps <b>Color 1</b> x14
x12	x26	x26	
			
Tapa Minifix / Cover Caps <b>Color 2</b> x12	Deslizador Puntilla / Nail-on Glide x6	Kit Antivuelco + Tornillos / Wall Fixing Kit + Screws x2	Manija / Handle x3
			
Tornillo Lámina / Flat Head Screw x8	Tornillo ensamble / Drywall screw x12	Rieles + tornillos / Slides + screws x3	Herraje unión esquinas / Corners basket x4
			
Puntilla / nail x28	Perfil H / H Profile x1		

## Cargas Máximas / Max Suggested Loads

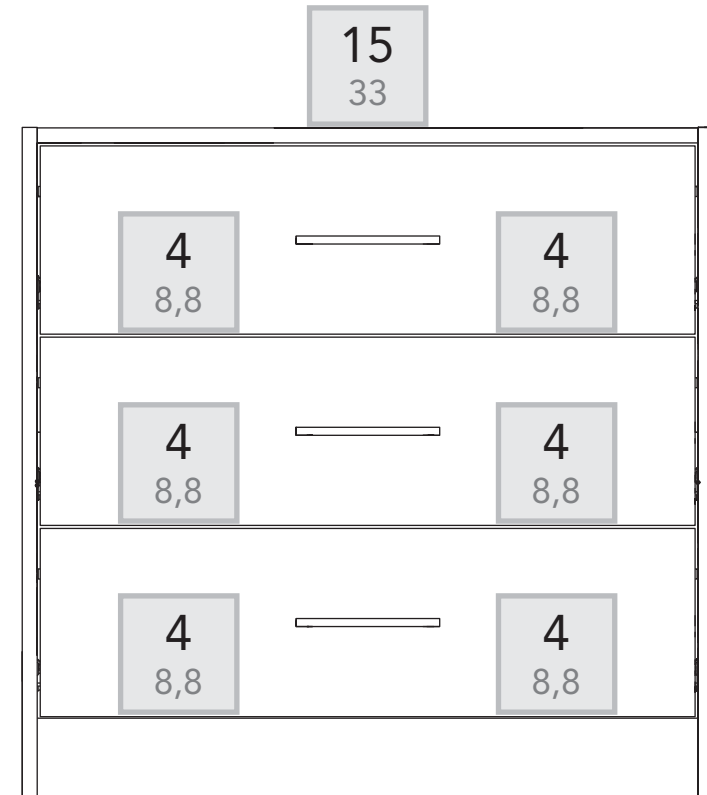

\*Peso en Kg / Weight in Kg.

\*Peso en Libras / Weight in Lb

# Piezas de Armado / Assembly Parts

A - x1
B - x1
C - x3
D - x3
E - x1
F - x3
G - x1
H - x3
I - x2
J - x3
K - x3
L - x1

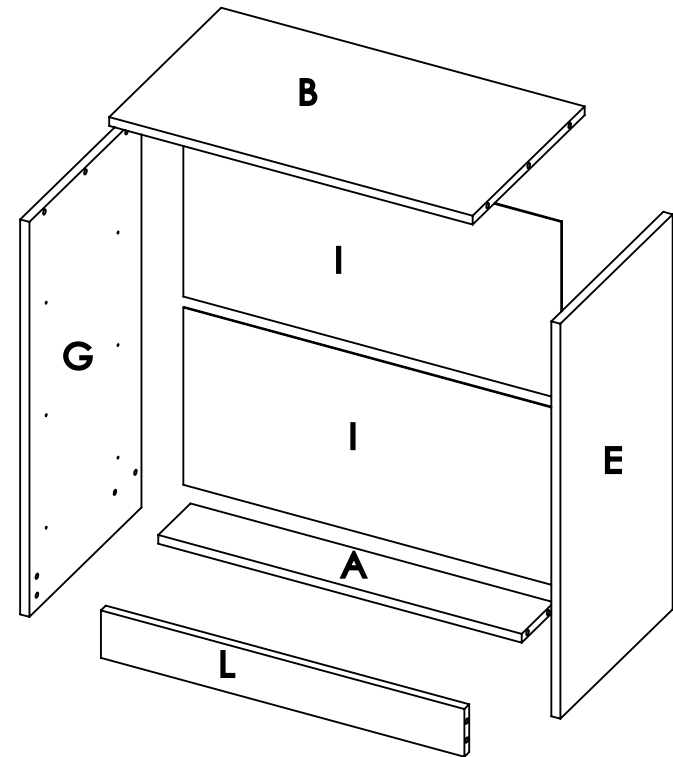
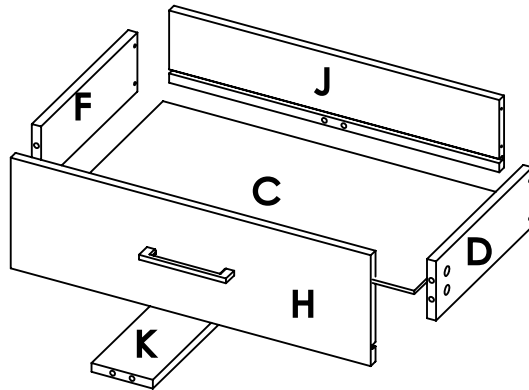
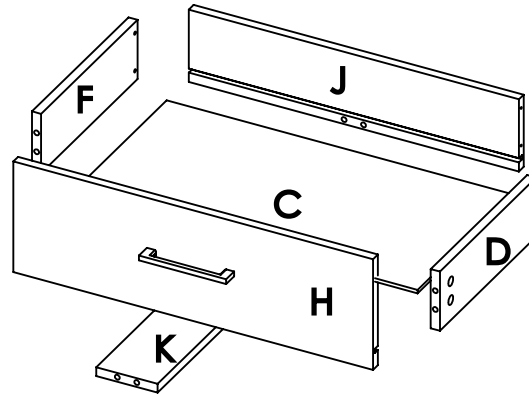
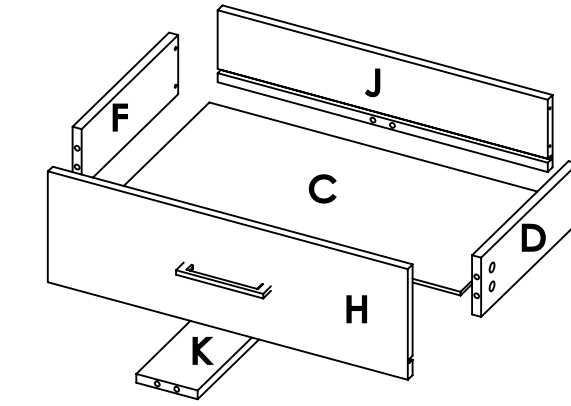

# 1

## Instalación de los rieles Drawer slides installation

Instalación de los rieles (aplica para los pasos 1 y 5)  
La rueda debe ir hacia la parte del frente de la pieza y hacia abajo, así:

Drawe installation (apply for steps 1 and 5)  
The wheel should go towards the front edge of the panel and facing down, like this:

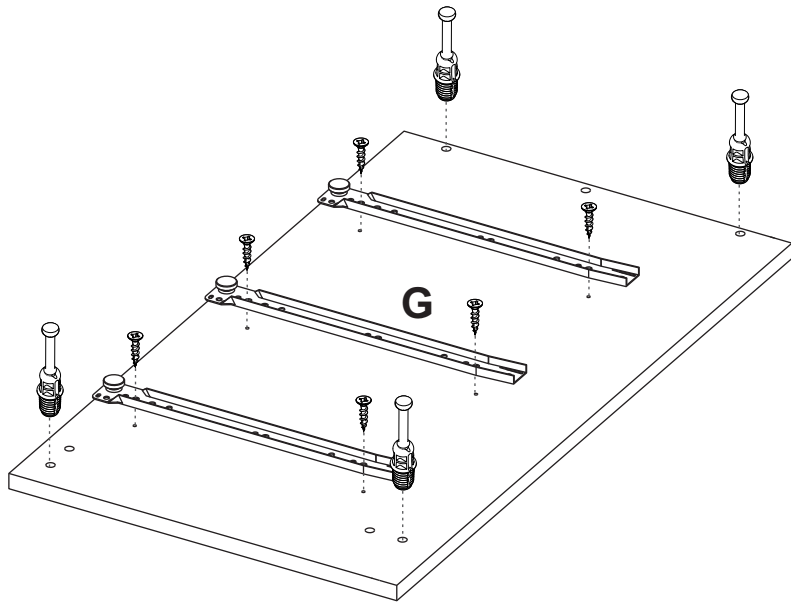
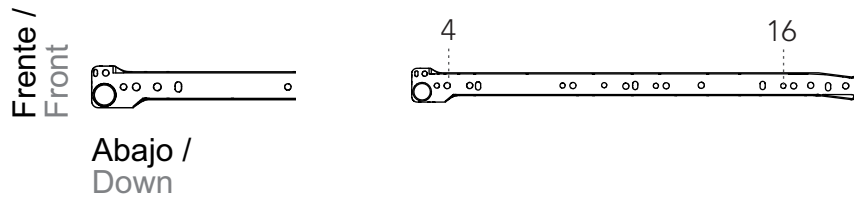

# 2

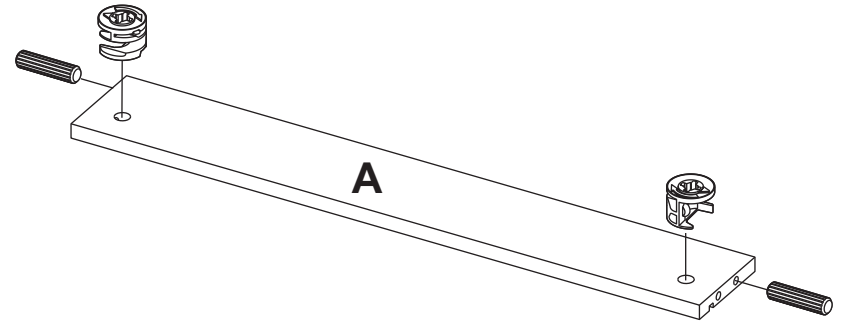

# 3

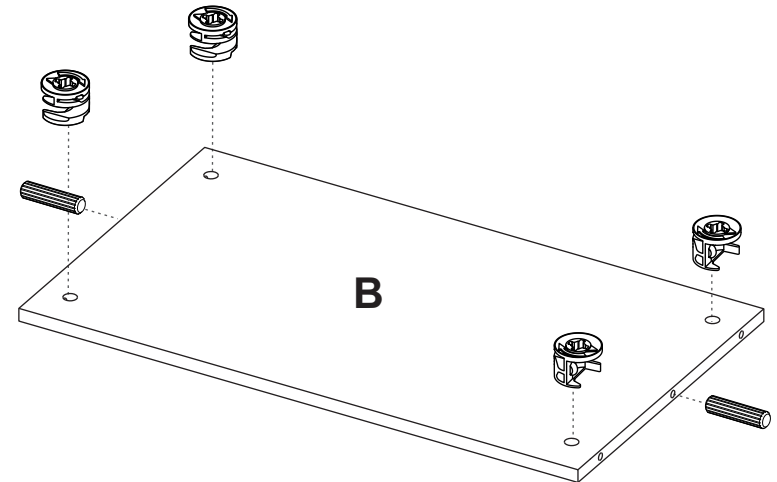

# 4

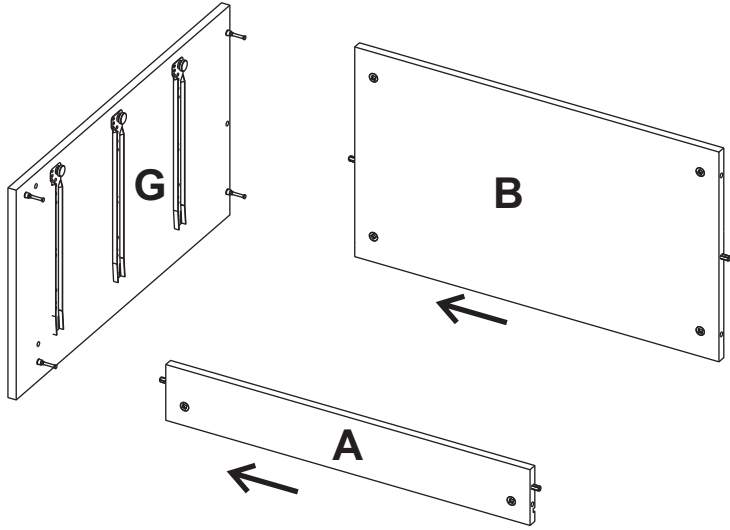

**5** Si quieres recordar cómo instalar los rieles, puedes ir nuevamente al paso 1.  
To recall the slides installation you can go to the 1th step again.

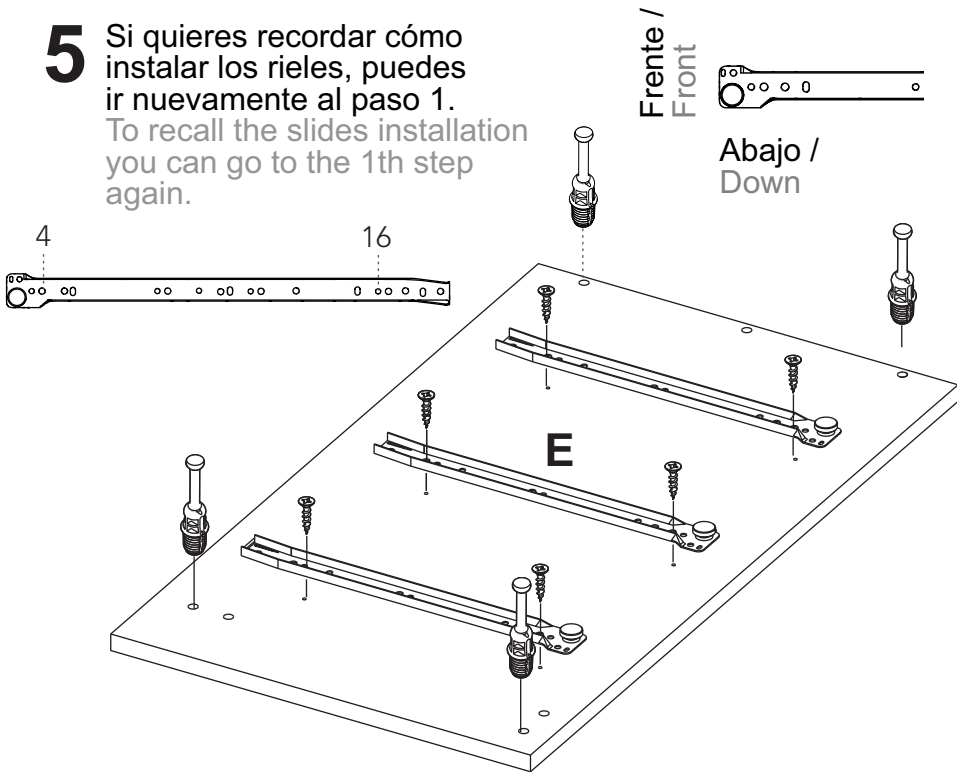

# 6

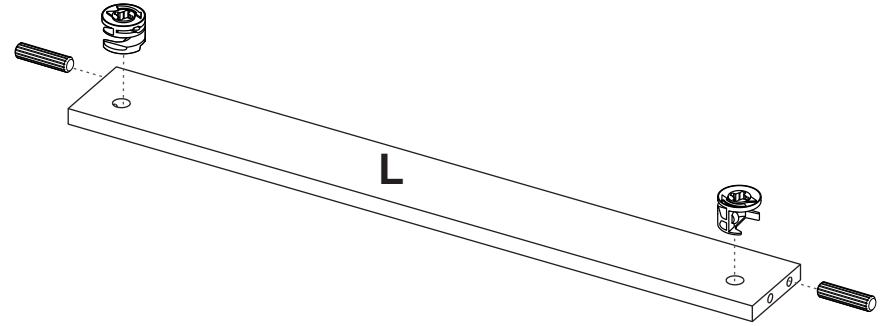

# 7

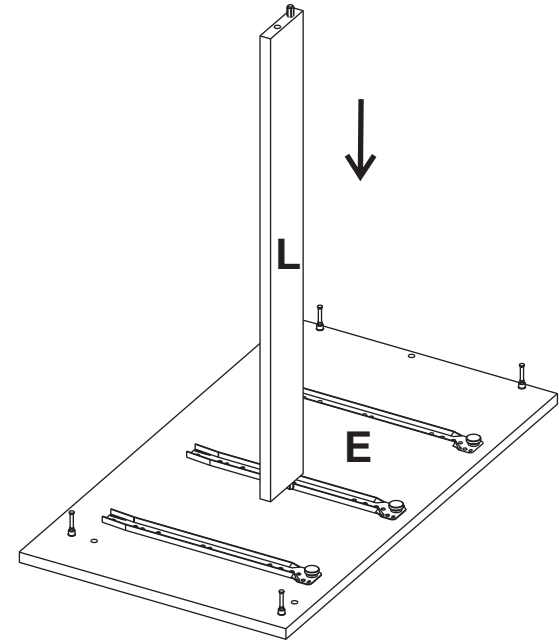

8

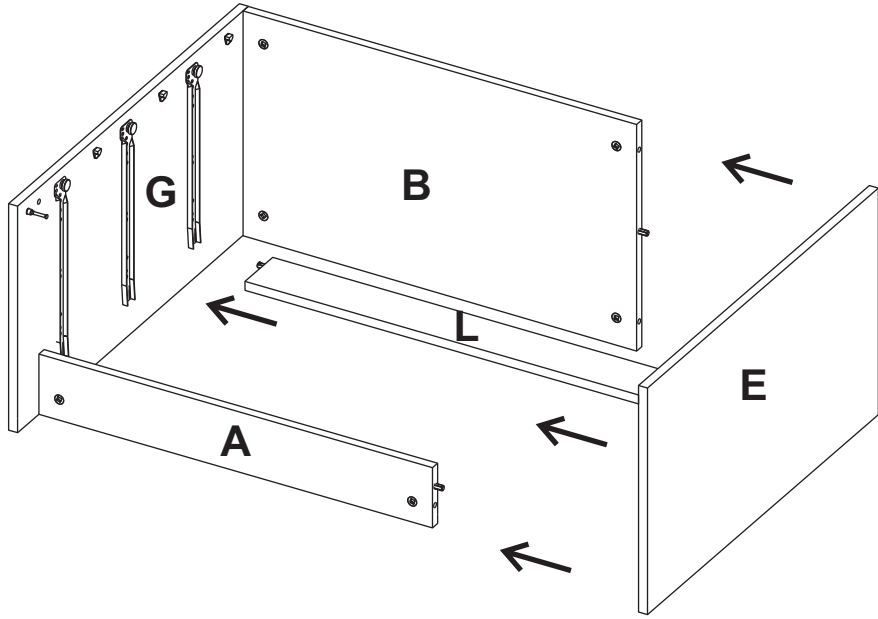

9

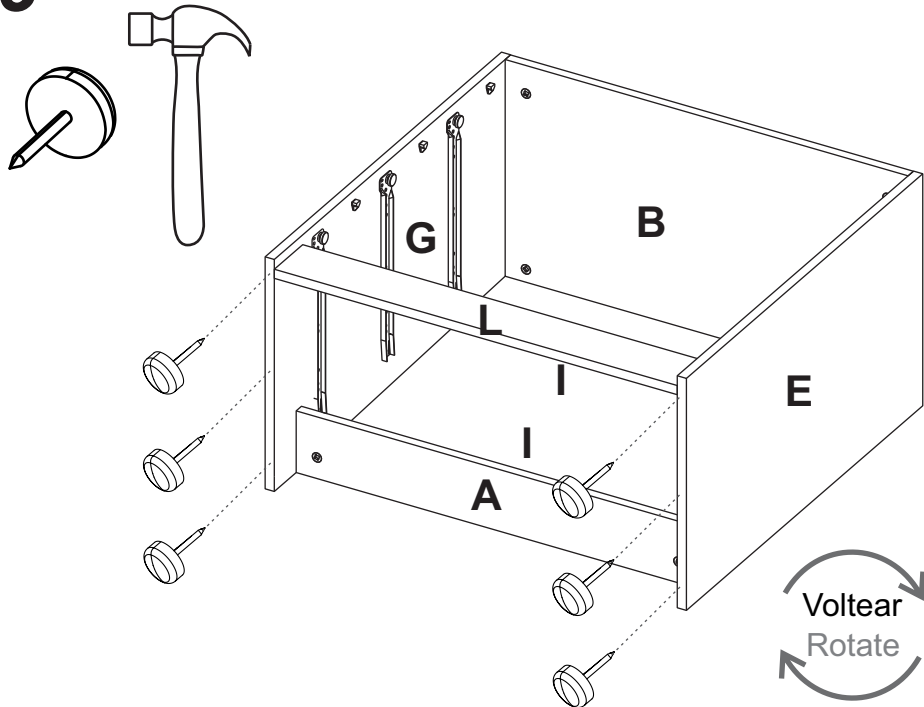

10

Ubica los soportes esquineros en las esquinas y atornille con tornillo lámina.  
Place the corner brackets in the corners and screw them in with sheet metal screws.

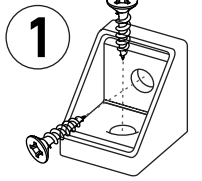
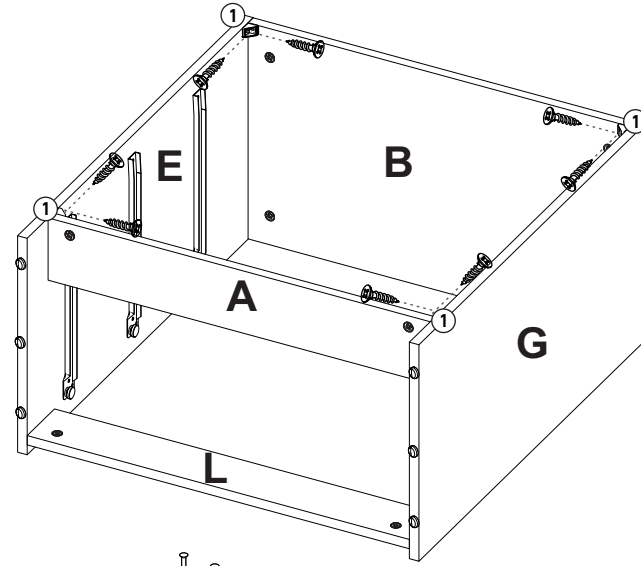

Soporte Esquinero

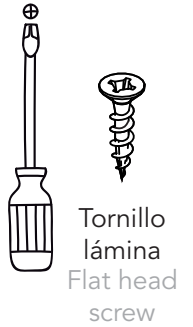

11

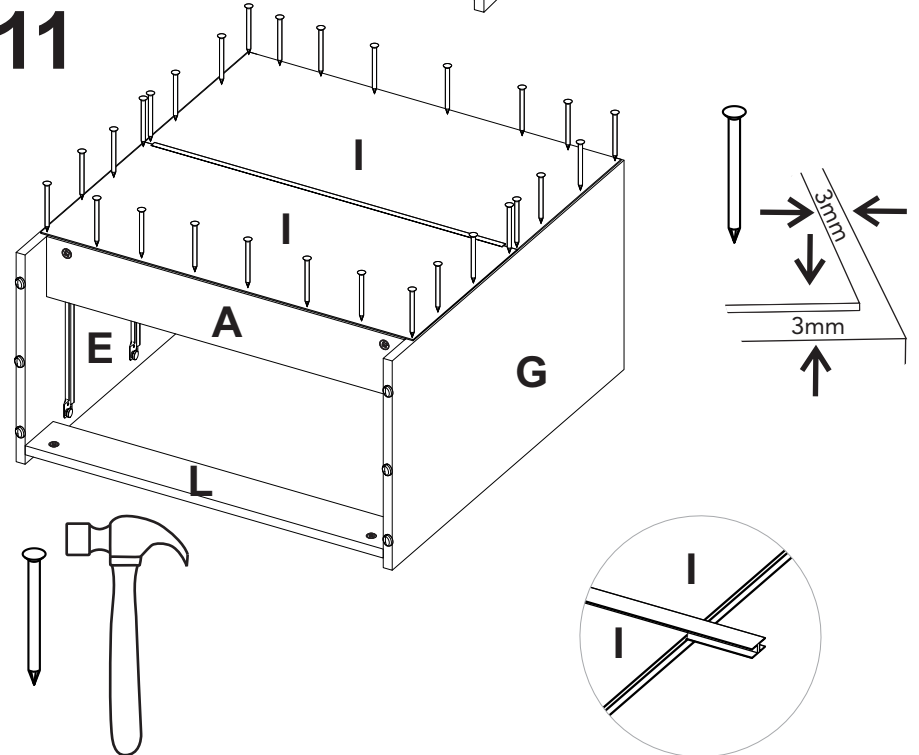

# 12

## Fija el mueble a la pared Fix your cabinet to the wall

- 1** Haz una perforación en el borde superior de la parte superior del mueble y fija un extremo de la correa con el tornillo de 15mm y una arandela.  
Make a small hole on the top edge of the furniture top and fix one side of the strip with the 15mm screw and the washer. 
- 2** Extiende la correa y mide en la pared para perforar.  
Stretch the strip and measure on the wall to drill. 
- 3** Perfora la pared a 30mm de profundidad con una broca de 6mm.  
Drill a hole in your wall to a depth of 30mm using a 6mm drill bit. 
- 4** Inserta el chazo plástico en la perforación.  
Insert the plastic wall anchor into the hole. 
- 5** Fija el otro extremo de la correa con la arandela y el tornillo que sobran.  
Fix the other side of the strip with the screw and the washer. 

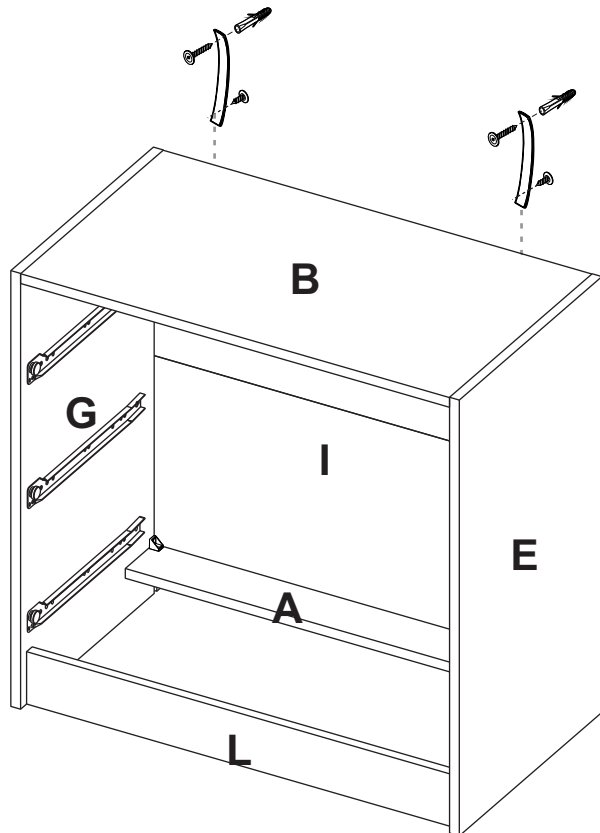

# 13

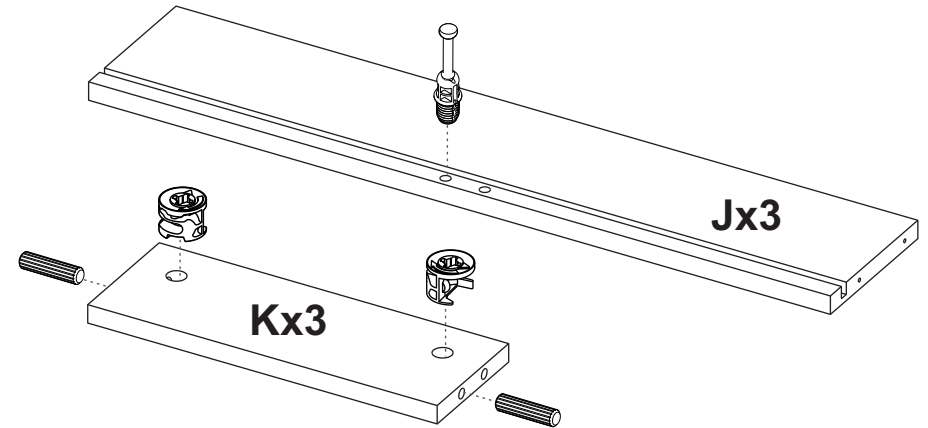

# 14 x3

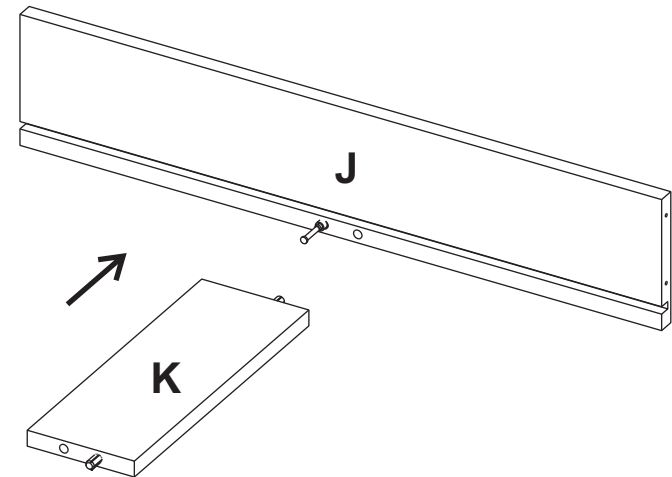

# 15

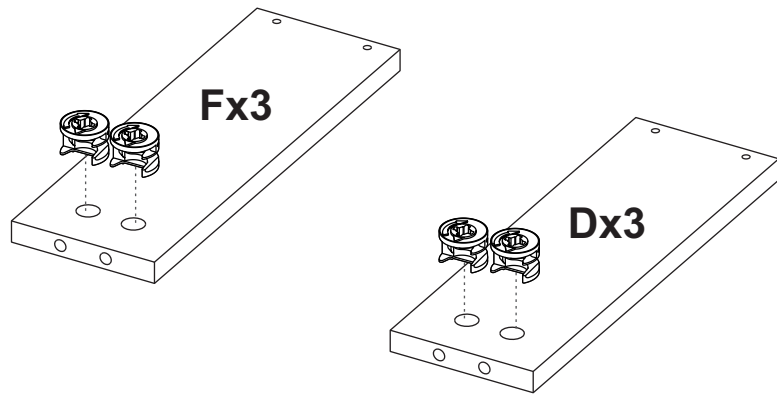

# 16 x3

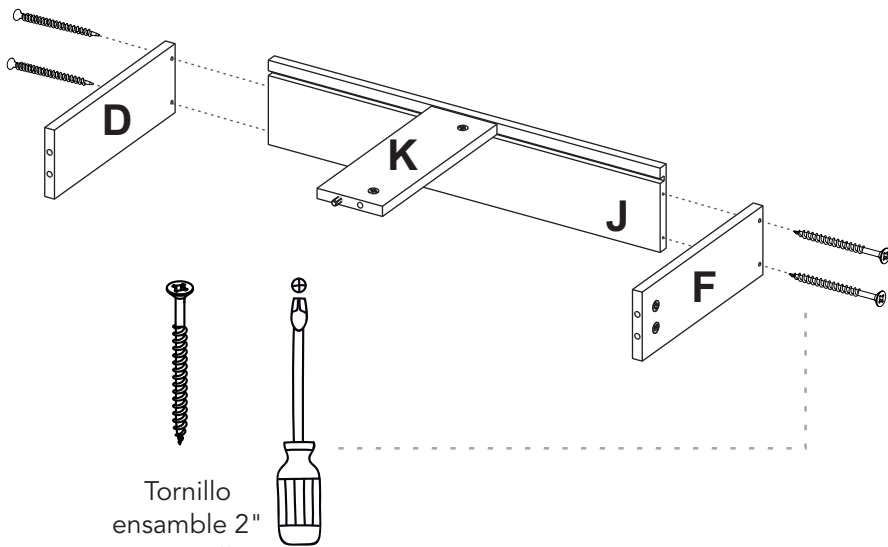

Tornillo  
ensamble 2"  
Drywall  
screw 2"

# 17 x3

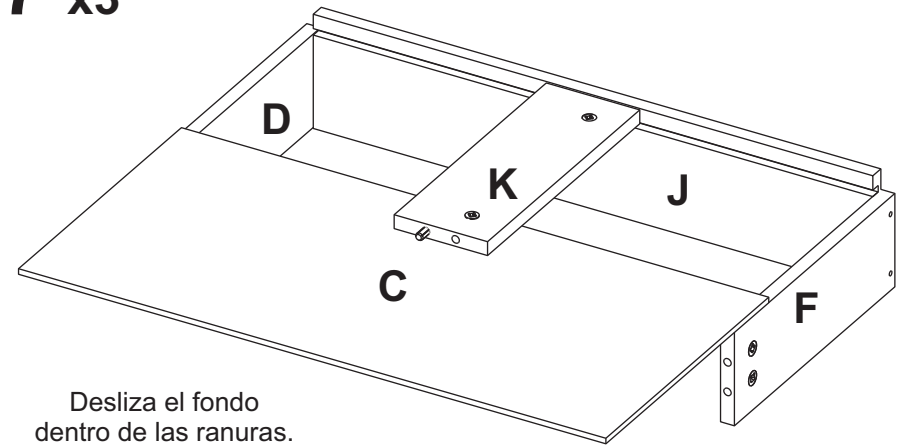

Desliza el fondo  
dentro de las ranuras.

Slide the back panel  
inside the grooves.

# 18

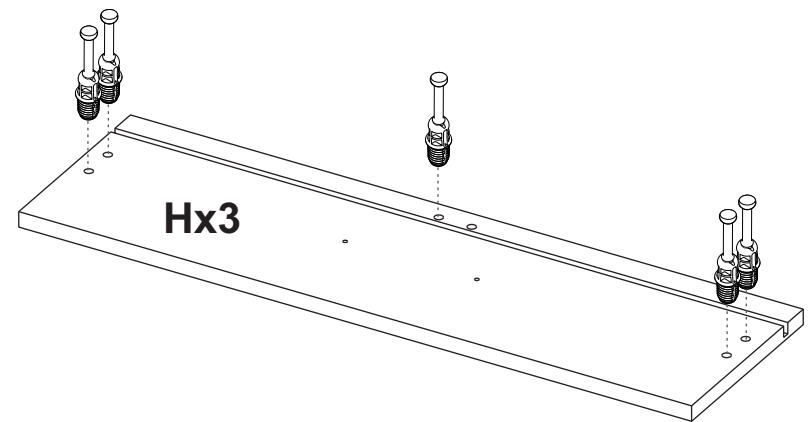

19 x3

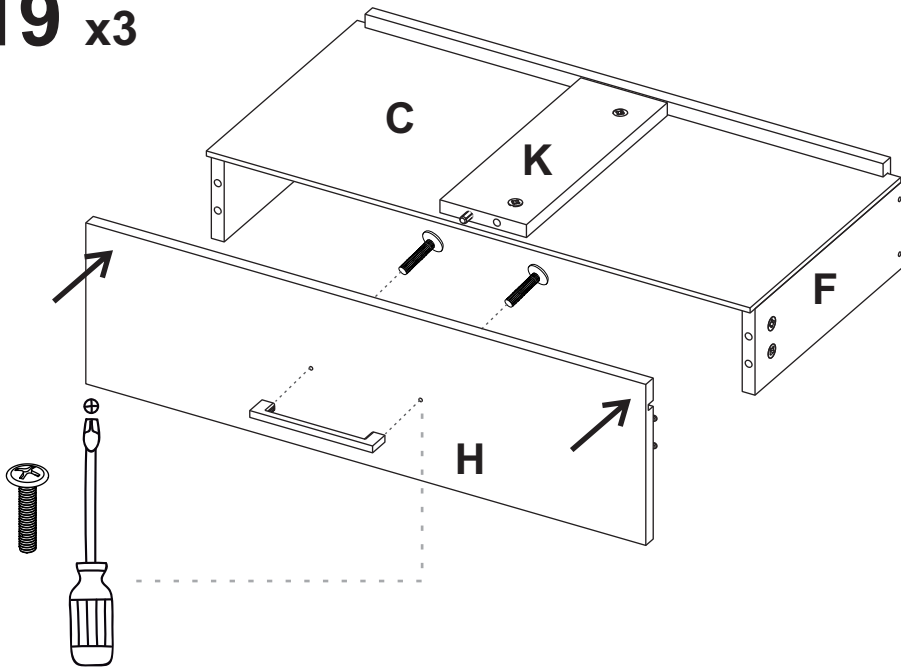

20 x3

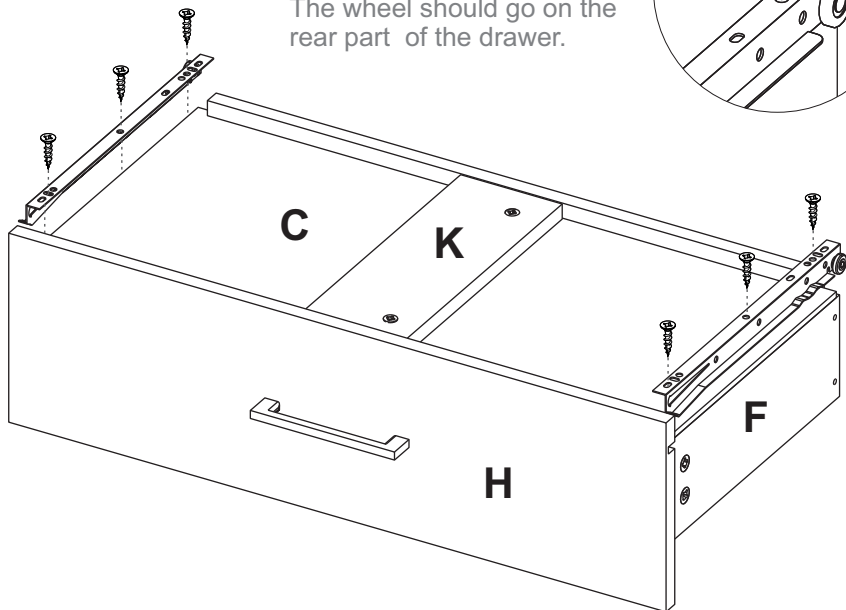

**Instalación de los cajones**  
**Drawer Installation**

La rueda del riel debe ir en la parte trasera del cajón.  
The wheel should go on the rear part of the drawer.

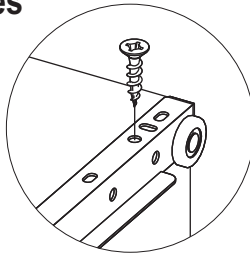

21

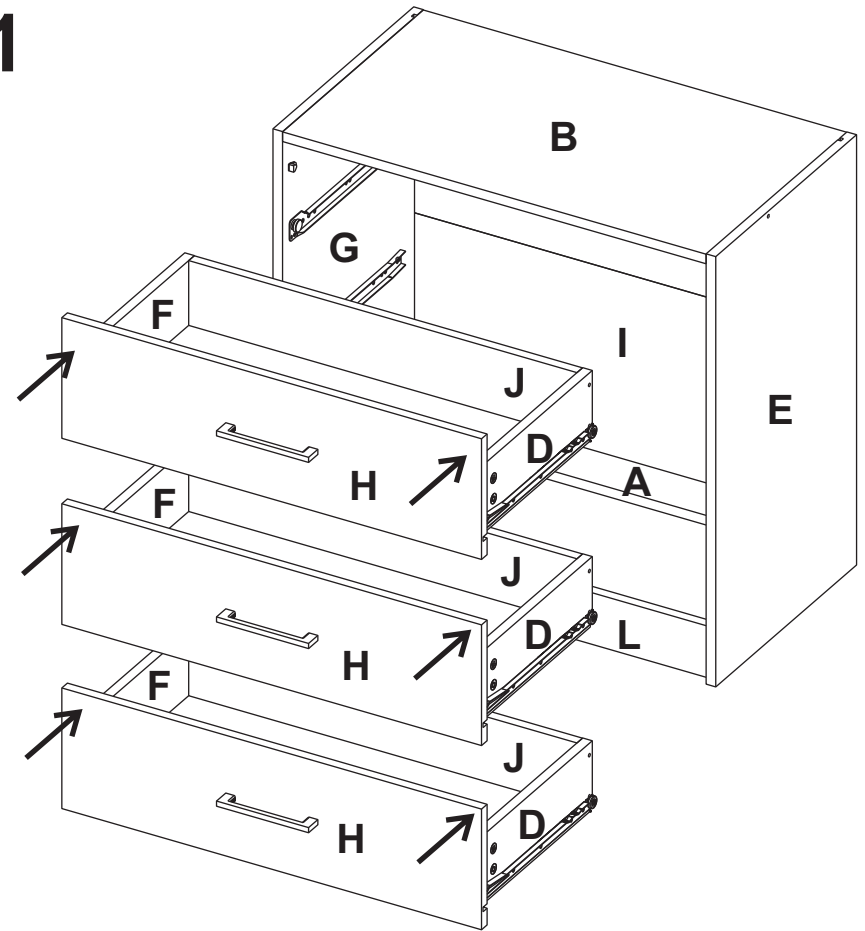

Para más información escanea AQUÍ/Scan for more info



Tapas minifix/  
Cover caps



Después de ajustar todas las cajas minifix y los tornillos, cúbralas con las tapas adhesivas.  
After you finish the adjustment of the cams and screws, cover them with the cover caps.

**A**

Al terminar de armar, desprenda las letras adhesivas.  
After you finish assembling the cabinet, take off the adhesive letters.