

ASSEMBLY INSTRUCTIONS MANUAL DE MONTAGEM / INSTRUCCIONES DE ARMADO

KOYA TOWER 2 FLAP DOORS 1 DRAWER BASEBOARD

TORRE 2PB 1G C/RODAPE KOYA

TORRE 2 PUERTAS HORIZONTALES 1 CAJÓN C/RODAPIÉ KOYA

Reference
Referência
Referencia

250194

| Revise
| Revisão
| Revisión

00

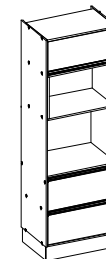

YOU WILL NEED VOCÊ VAI PRECISAR DE / USTED NECESITARÁ

Tools not supplied
Ferramentas não fornecidas / Herramientas no incluidas

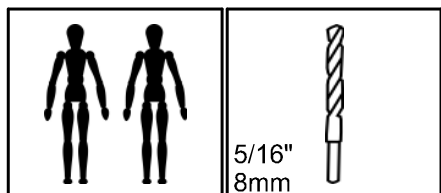

2 People
2 Pessoas
2 Personas

Drill bit
Broca
Taladro

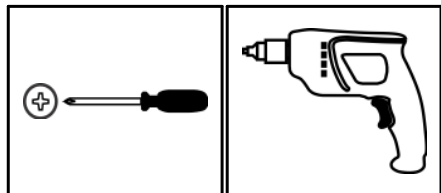

Screwdriver Phillips
Chave Phillips
Destornillador cruz

Drill machine
Furadeira
Taladro

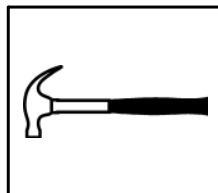

Hammer
Martelo
Martillo

MAXIMUM RECOMMENDED WEIGHT BEING THIS EVENLY DISTRIBUTED.
PESO MÁXIMO RECOMENDADO SENDO ESTE DISTRIBUÍDO UNIFORMEMENTE.
PESO MÁXIMO RECOMENDADO SIENDO ESTE UNIFORMEMENTE DISTRIBUIDO.

	LB	KG
—		
D	11	5
E	17	8
F	22	10

PARTS IDENTIFICATION IDENTIFICAÇÃO DAS PEÇAS / IDENTIFICACIÓN DE LAS PIEZAS

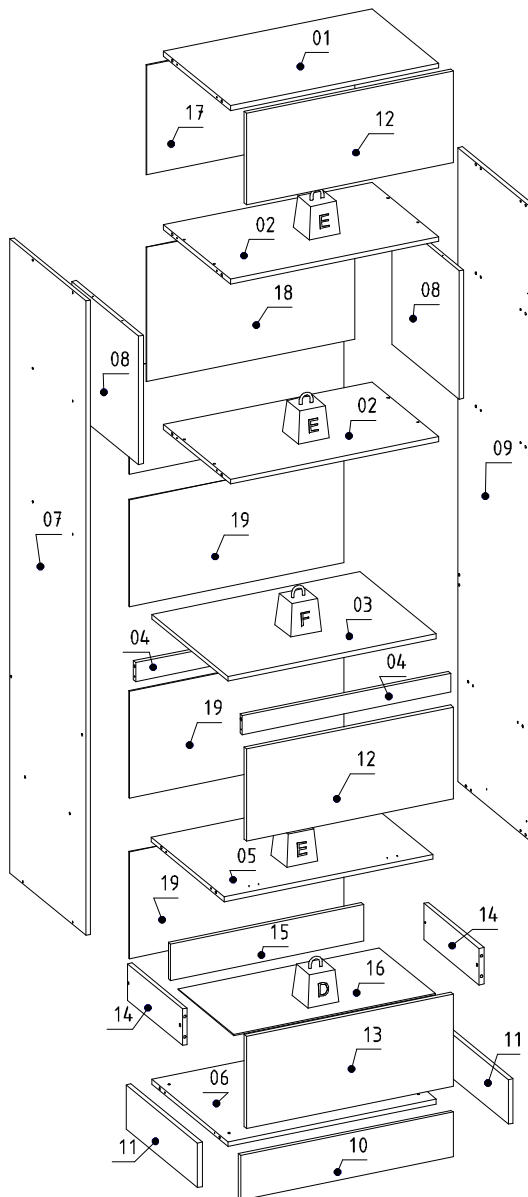

Nº	Measures_Inches	Medidas_cm	Qty./Qtd.
01	26 3/8 x 16 7/8 x 5/8	67.0 x 43.0 x 1.5	1
02	26 3/8 x 16 7/8 x 5/8	67.0 x 43.0 x 1.5	2
03	26 3/8 x 19 1/4 x 5/8	67.0 x 49.0 x 1.5	1
04	26 3/8 x 2 3/8 x 5/8	67.0 x 6.0 x 1.5	2
05	26 3/8 x 18 5/8 x 5/8	67.0 x 47.2 x 1.5	1
06	26 3/8 x 19 1/4 x 5/8	67.0 x 49.0 x 1.5	1
07	78 3/4 x 19 1/4 x 5/8	200.0 x 49.0 x 1.5	1
08	16 x 16 7/8 x 5/8	40.5 x 43.0 x 1.5	2
09	78 3/4 x 19 1/4 x 5/8	200.0 x 49.0 x 1.5	1
10	26 7/8 x 5 1/2 x 5/8	68.4 x 14.0 x 1.5	1
11	18 1/8 x 5 1/2 x 5/8	46.0 x 14.0 x 1.5	2
12	11 3/8 x 26 1/8 x 5/8	29.0 x 66.5 x 1.5	2
13	11 3/8 x 26 1/8 x 5/8	29.0 x 66.5 x 1.5	1
14	14 x 4 1/2 x 5/8	35.5 x 11.5 x 1.5	2
15	24 1/2 x 4 1/2 x 5/8	62.1 x 11.5 x 1.5	1
16	25 1/2 x 14 1/8 x 1/8	64.7 x 36.0 x 0.3	1
17	26 3/8 x 13 5/8 x 1/8	67.0 x 34.6 x 0.3	1
18	26 3/8 x 16 3/4 x 1/8	67.0 x 42.4 x 0.3	1
19	27 1/8 x 13 1/4 x 1/8	69.0 x 33.7 x 0.3	4

PRE-ASSEMBLE
PRÉ-MONTAGEM / PRE ARMADO

01

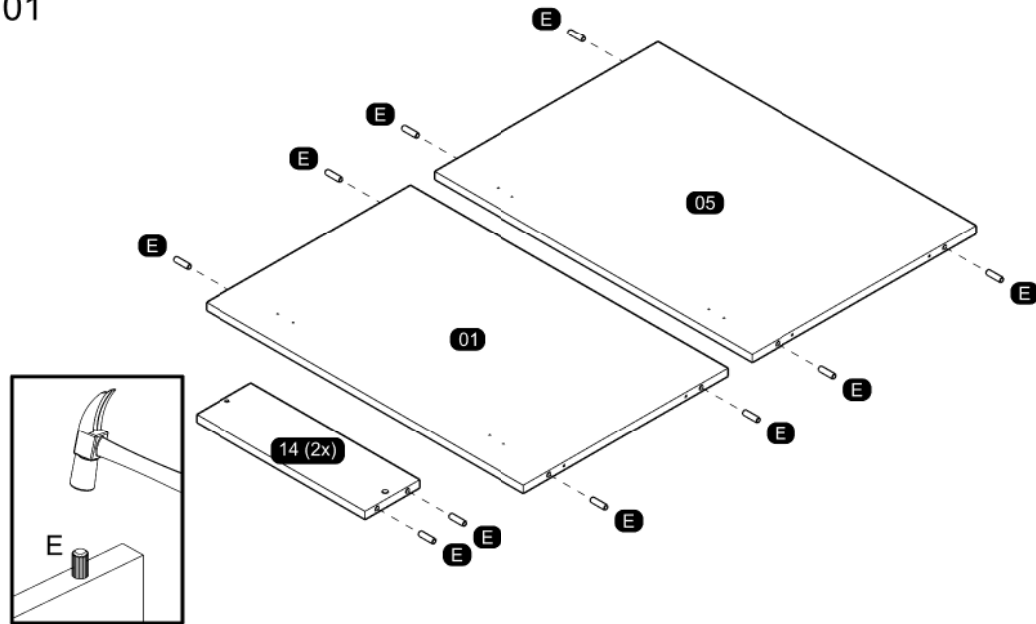

02

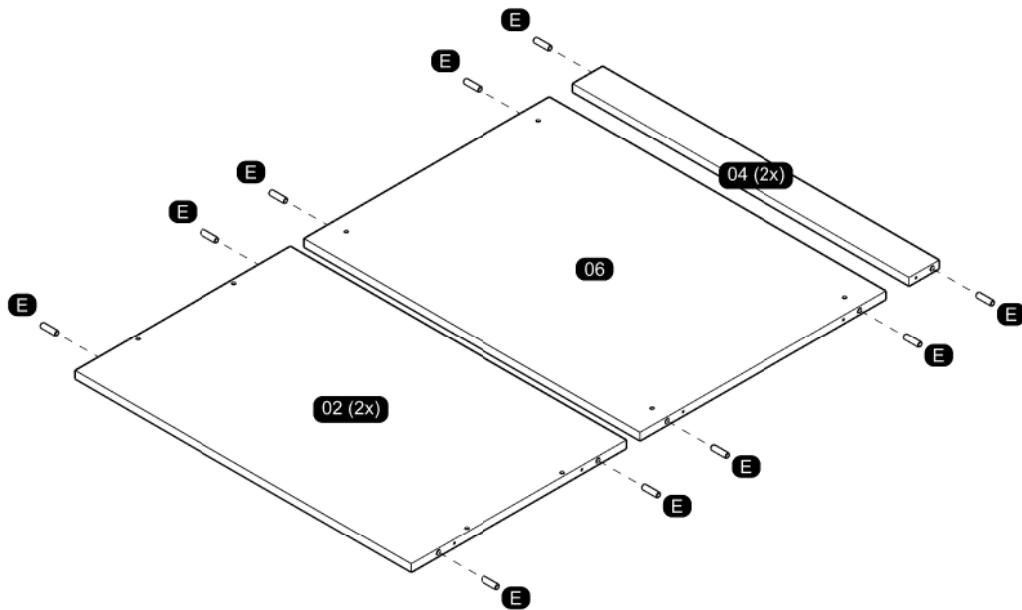

03

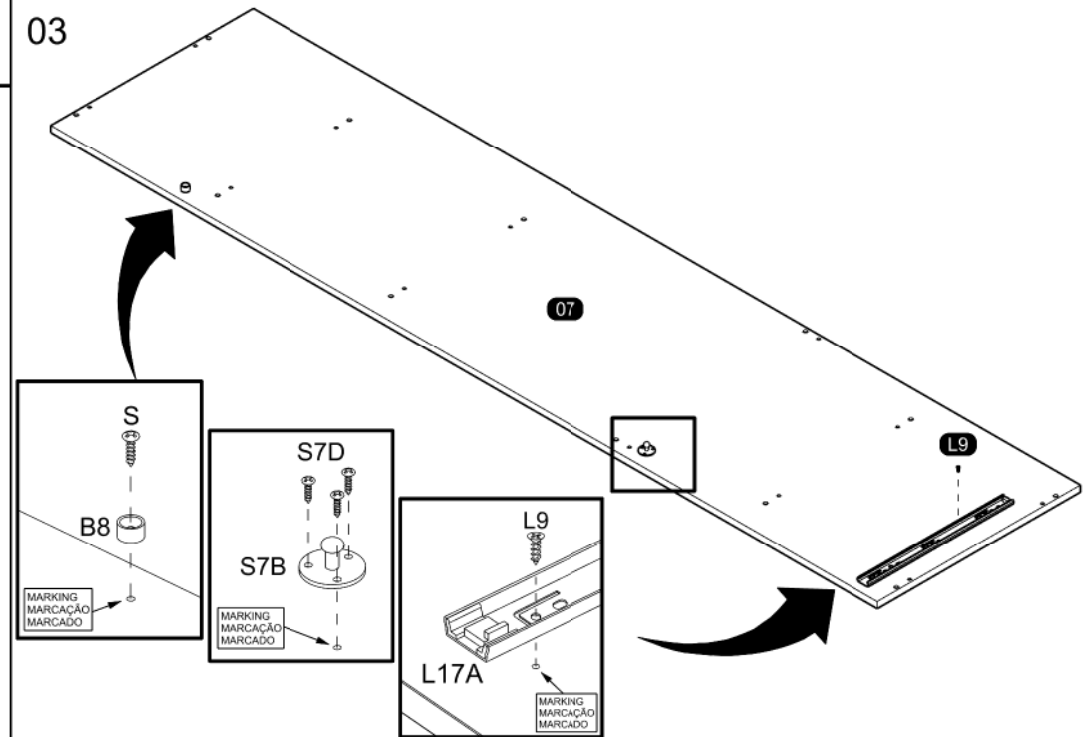

04

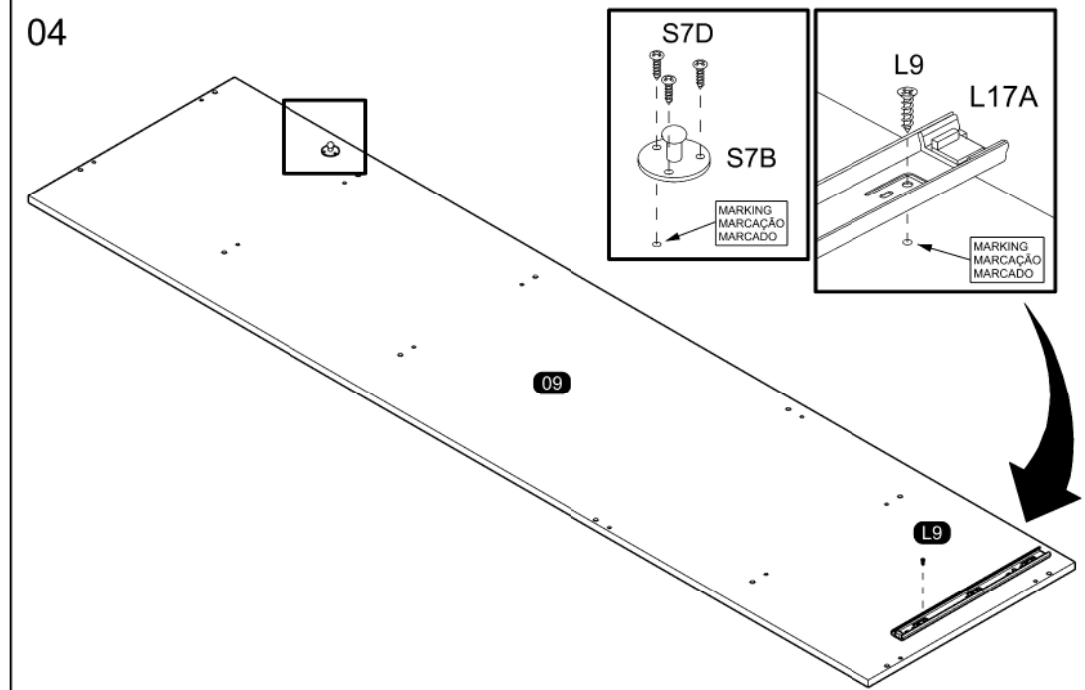

05

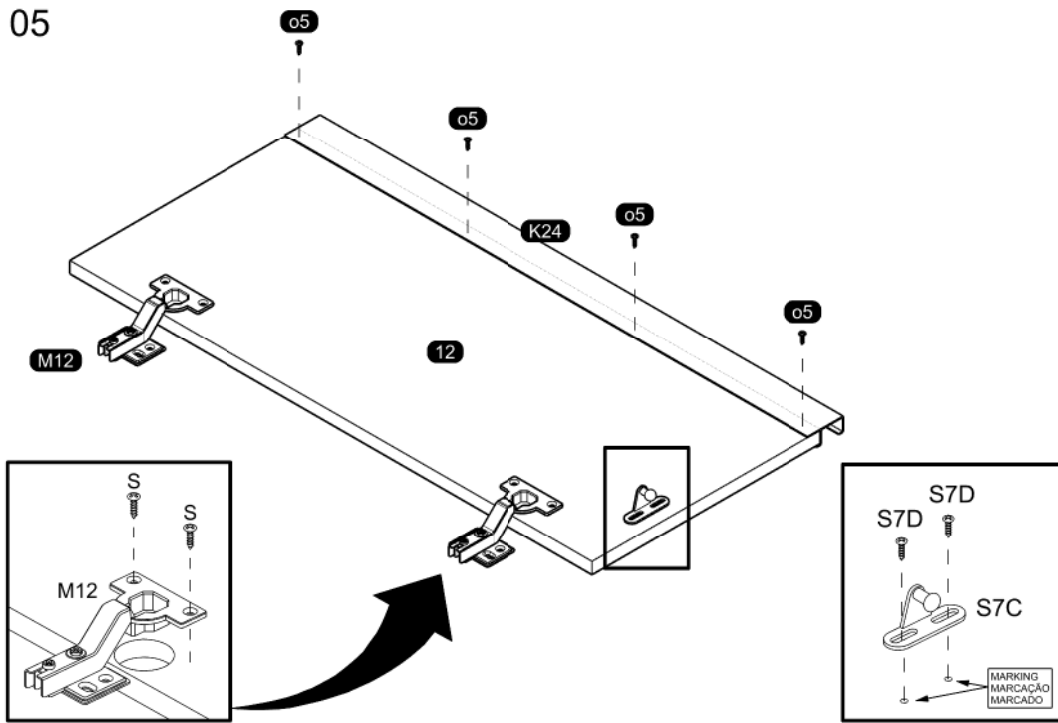

**ASSEMBLY
MONTAGEM / ARMADO**

07

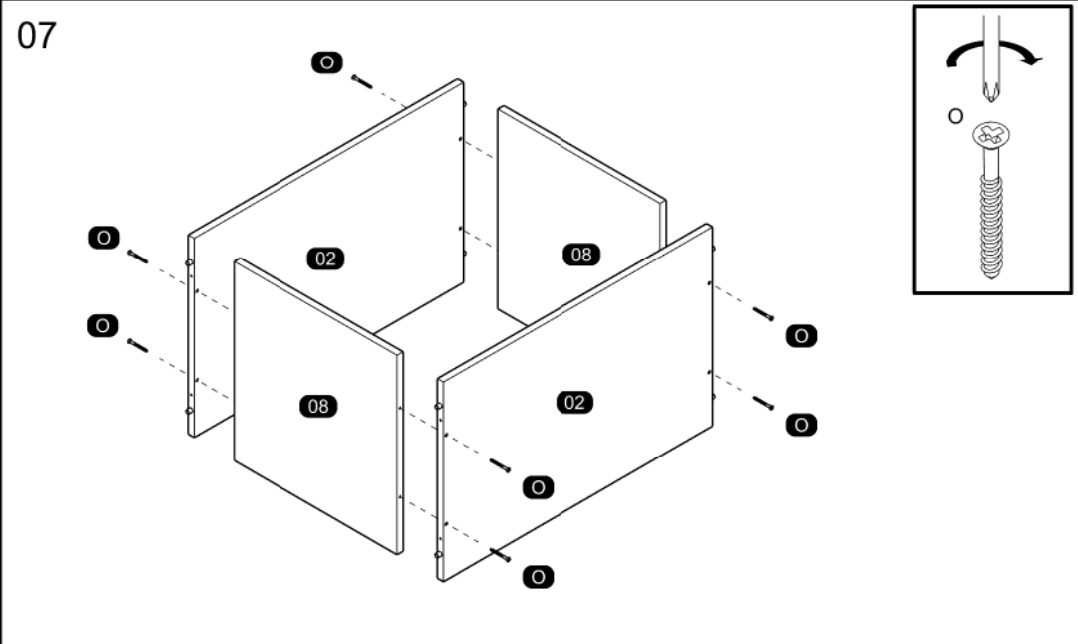

06

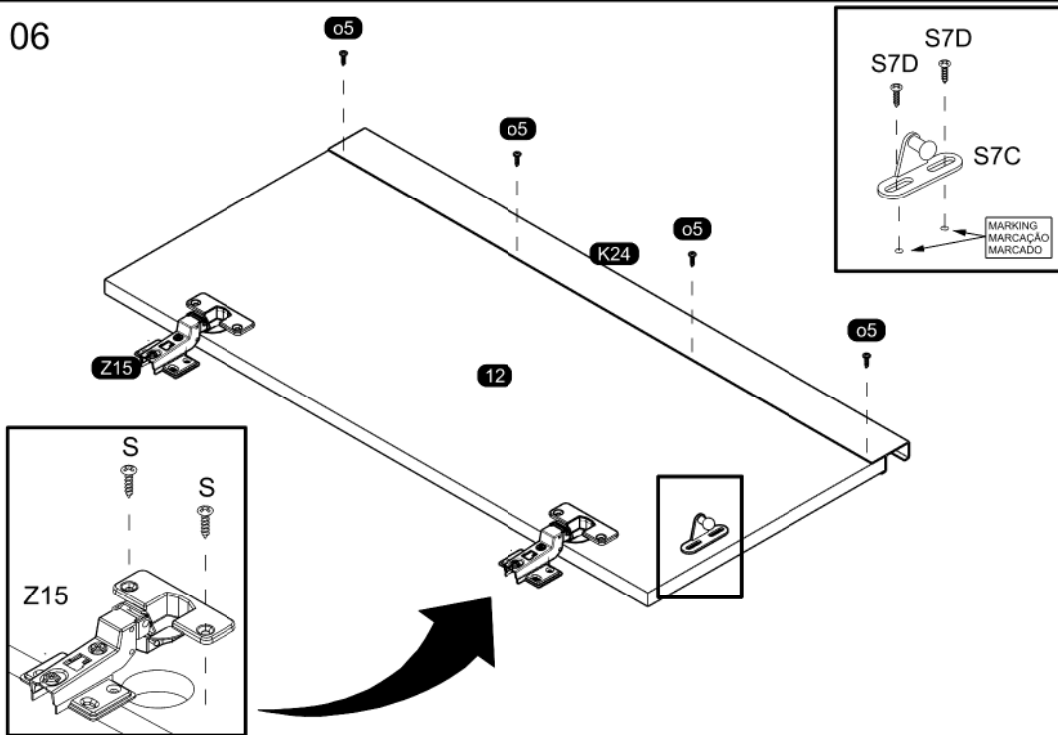

08

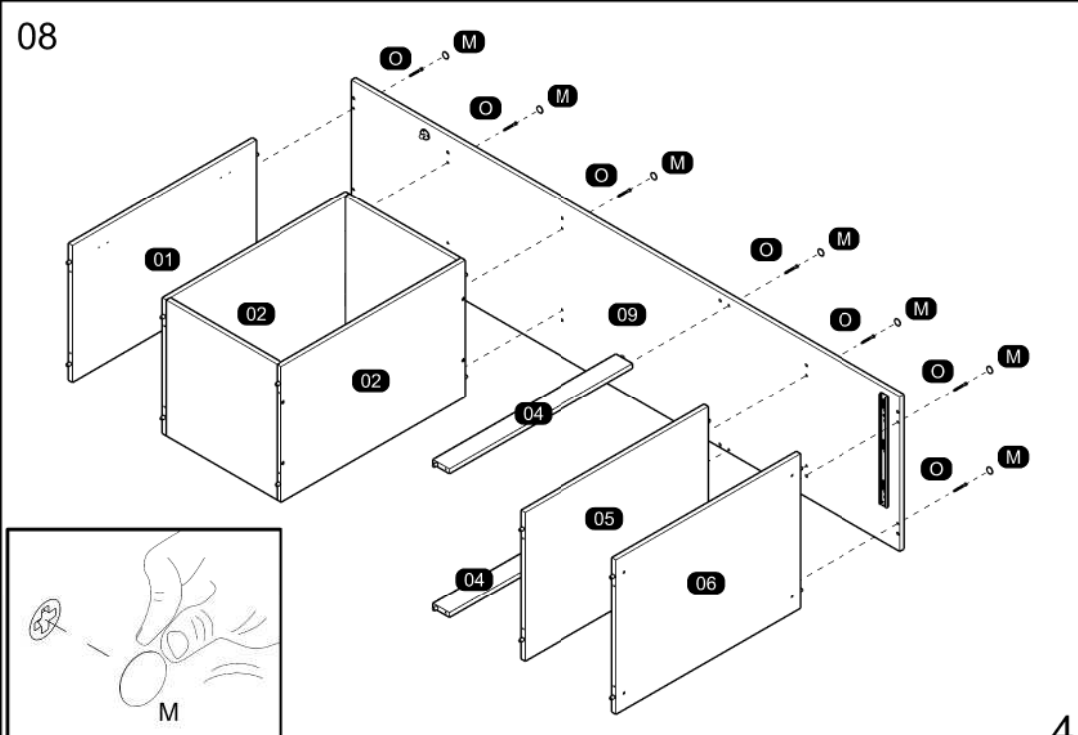

09

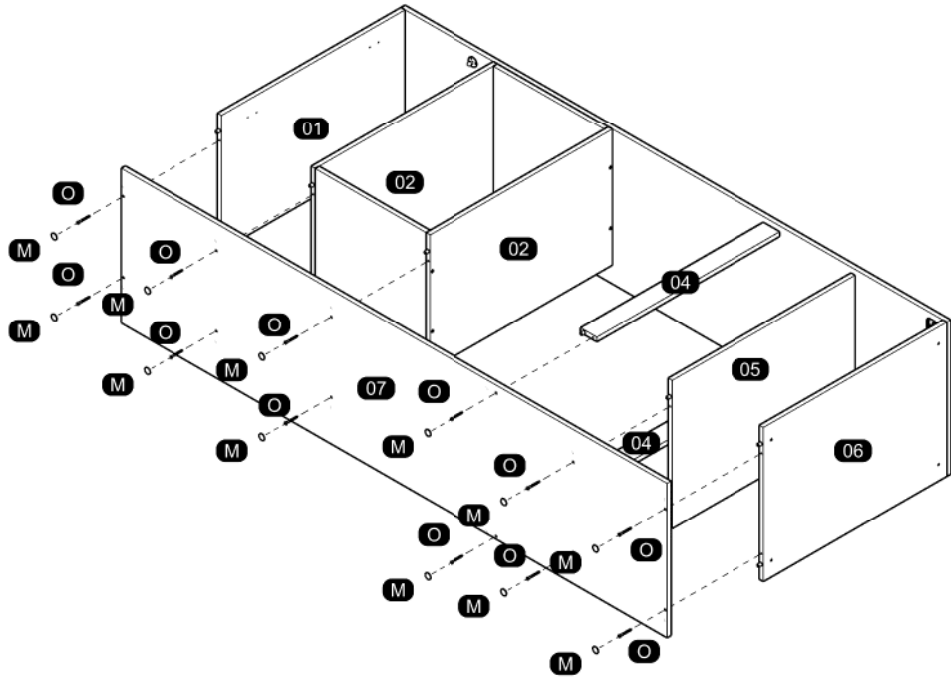

11

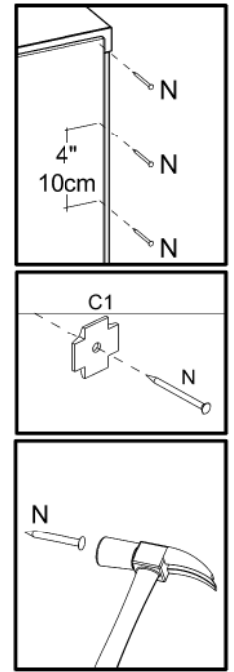
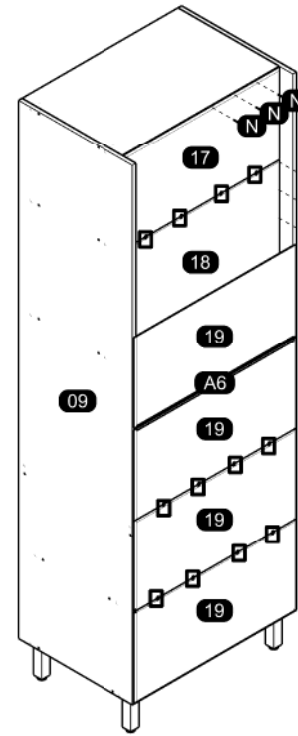

10

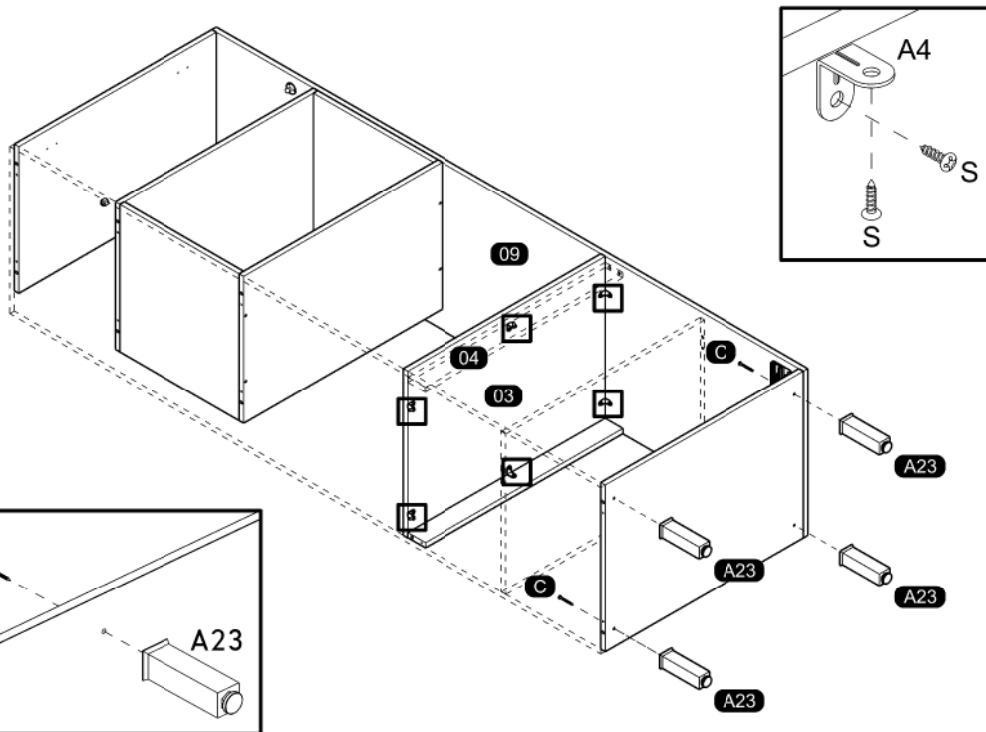

12

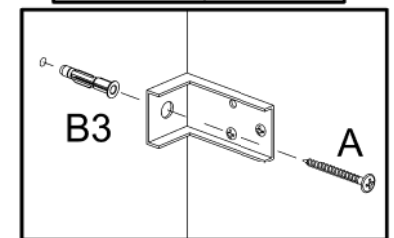
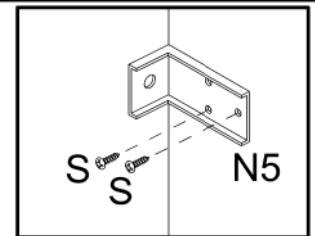
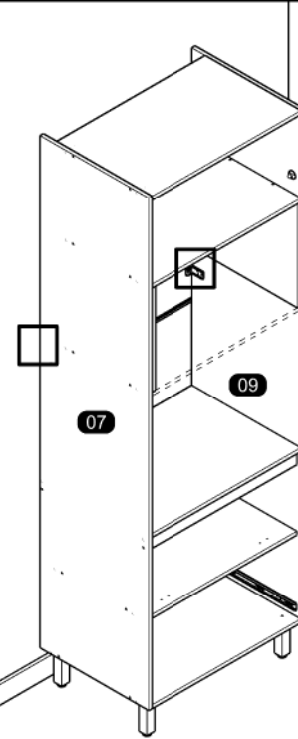

13

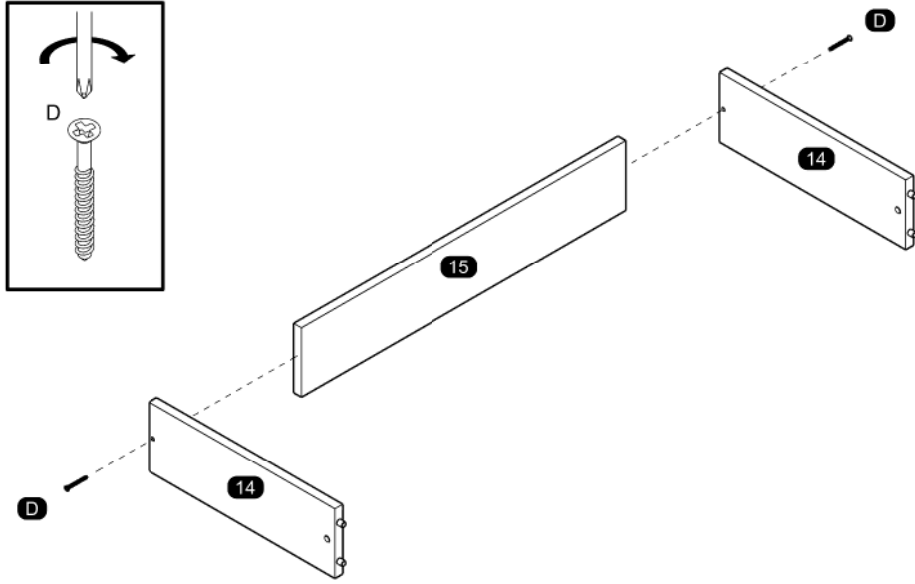

15

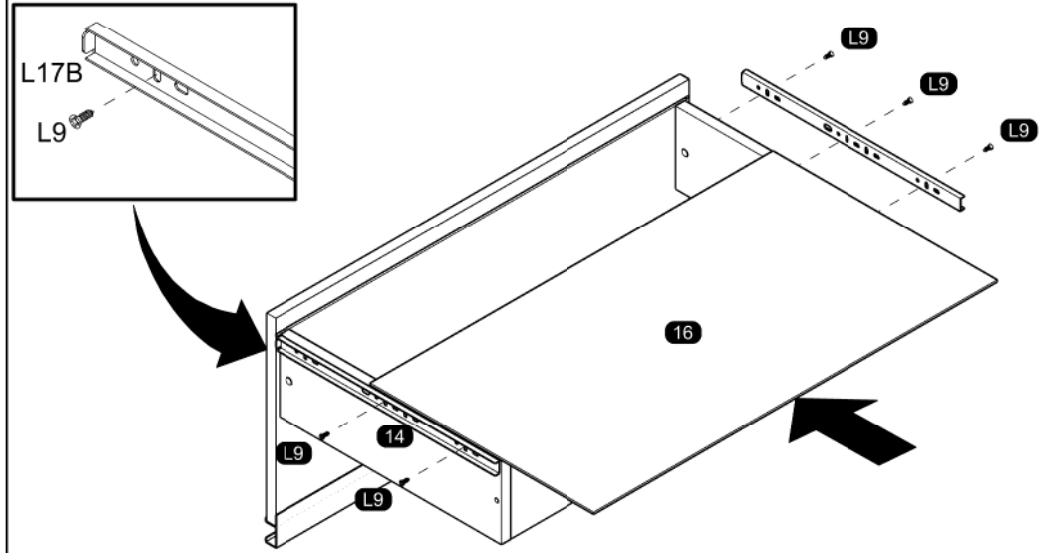

14

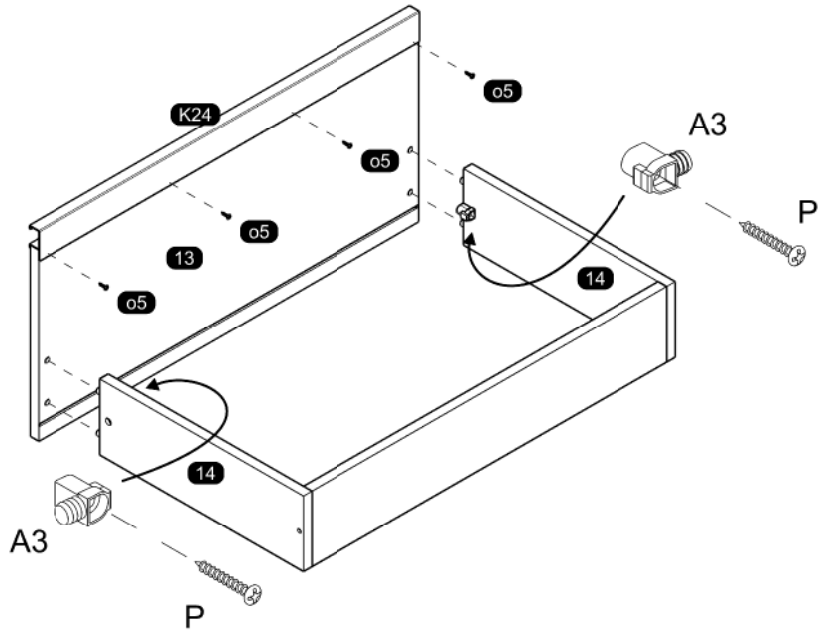

16

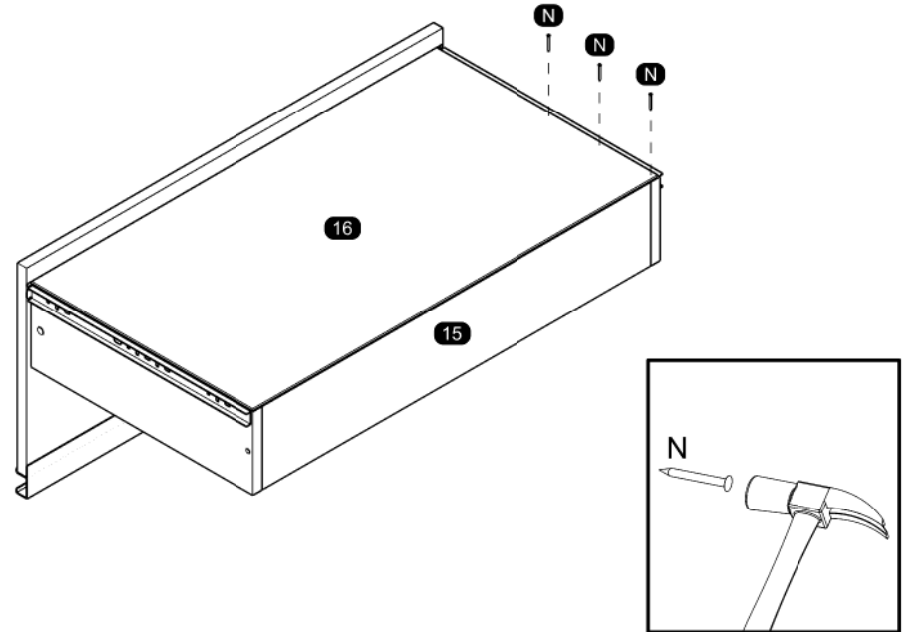

17

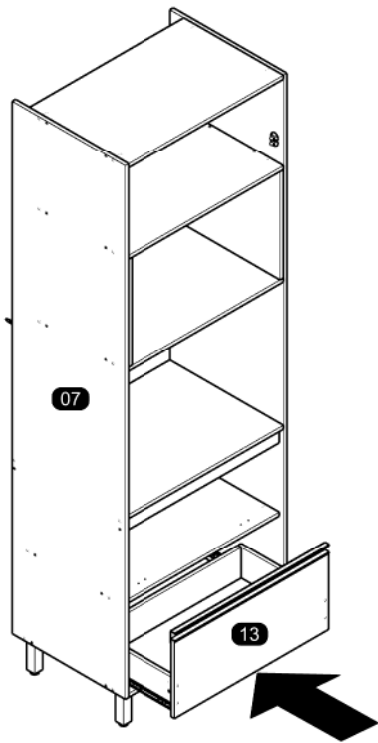

Drawer insertion
Inserção de gaveta
Inserción del cajón

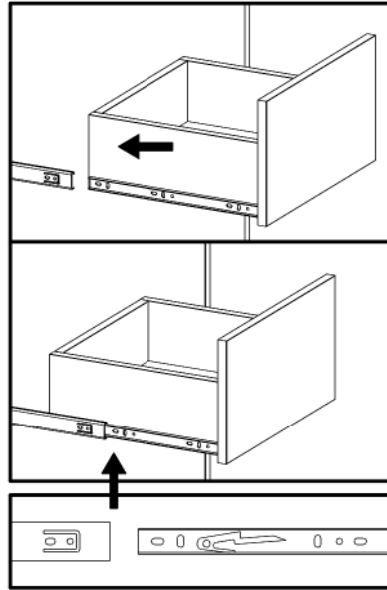

19

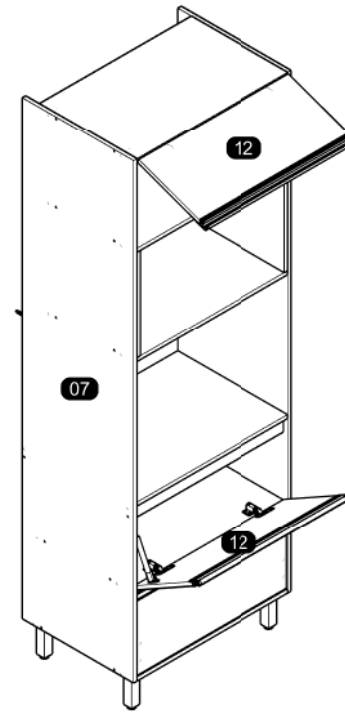
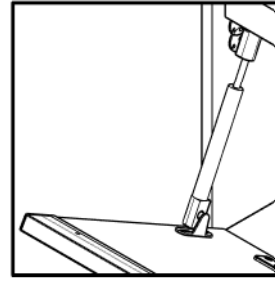

Follow the instruction corresponding to the template you received.
Siga a instrução correspondente ao modelo que recebeu.
Siga las instrucciones correspondientes al modelo que recibió.

Model 1 / Modelo 1 Model 2 / Modelo 2

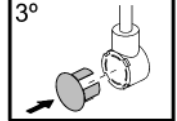
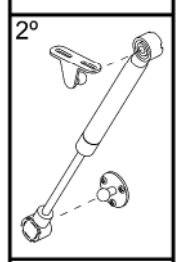
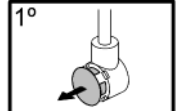
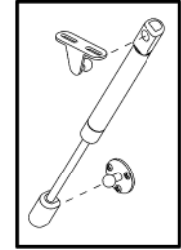

18

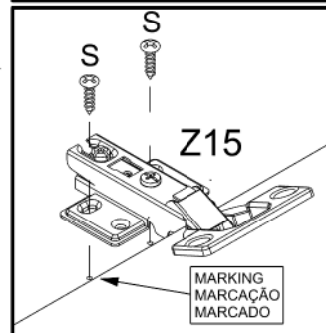
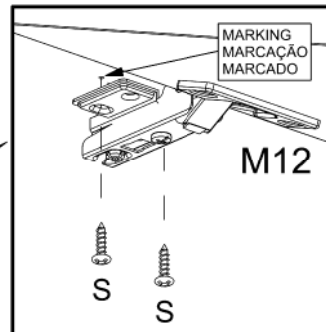
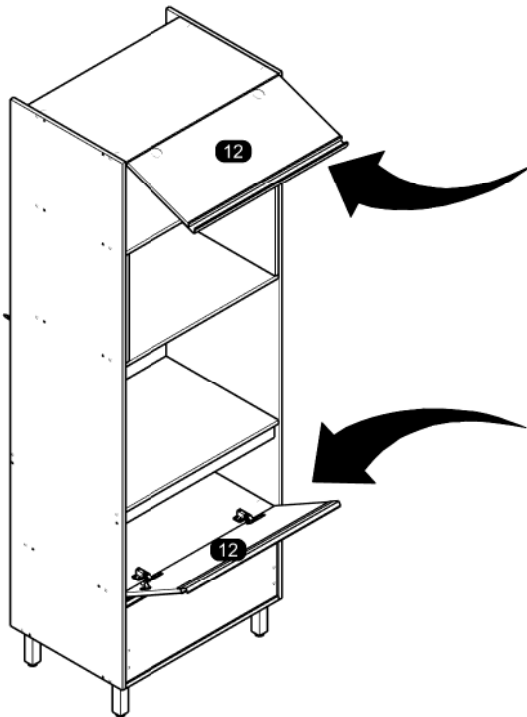

20

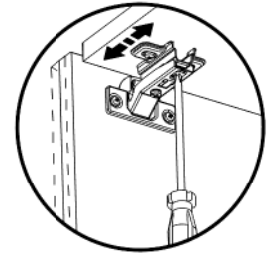
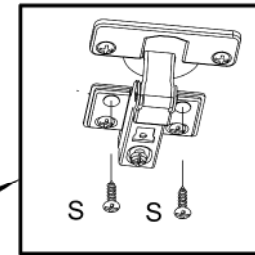
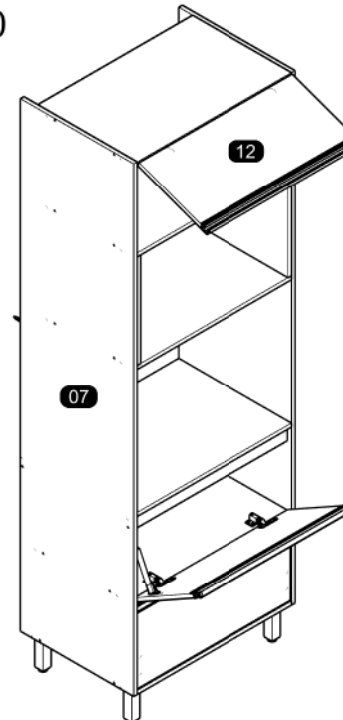

Depth Adjustment
Regulagem Profundidade
Ajuste Profundidad

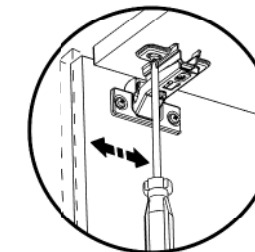

Horizontal Adjustment
Regulagem Horizontal
Ajuste Horizontal

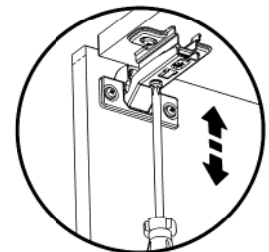

Vertical Adjustment
Regulagem Vertical
Ajuste Vertical

21

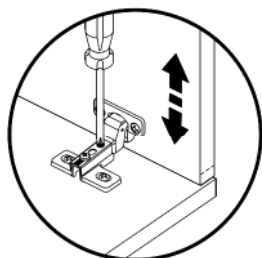
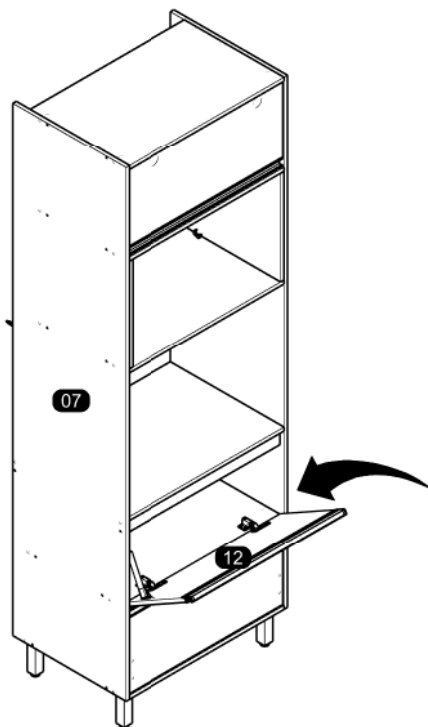

Vertical Adjustment
Regulagem Vertical
Ajuste Vertical

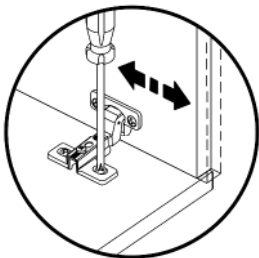

Horizontal Adjustment
Regulagem Horizontal
Ajuste Horizontal

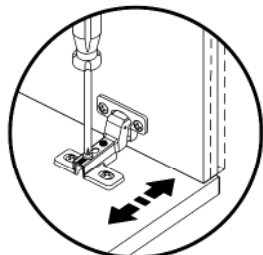
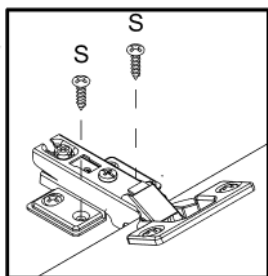

Depth Adjustment
Regulagem Profundidade
Ajuste Profundidad

23

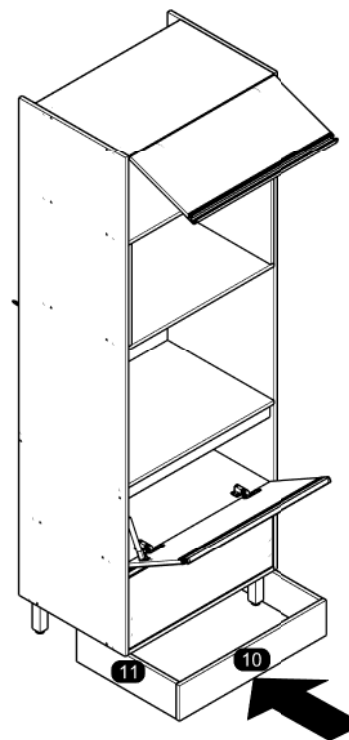

22

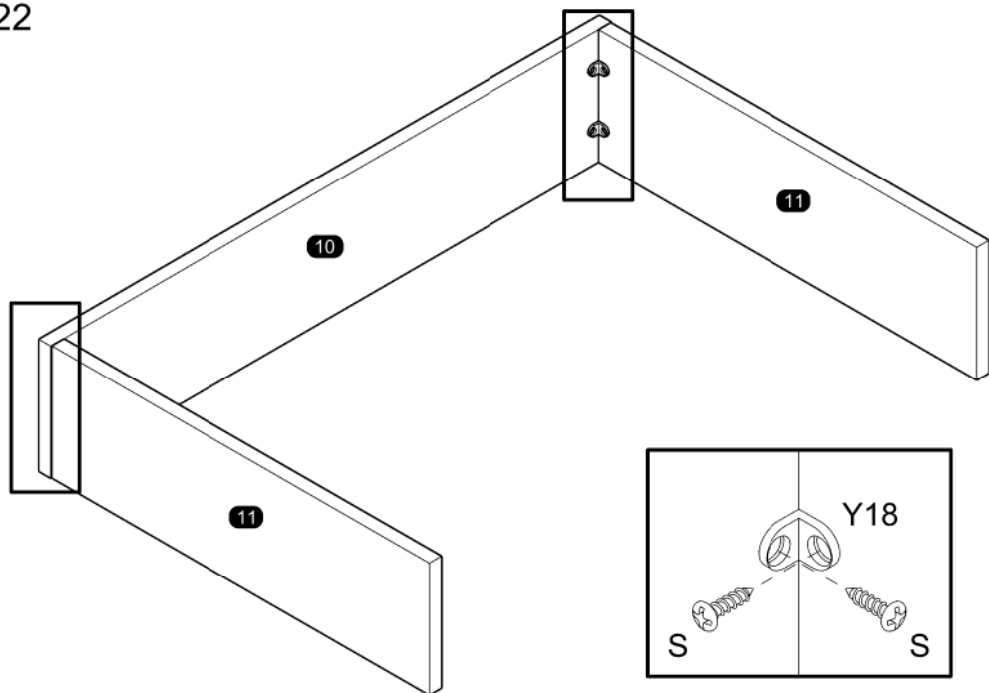

24

