

ASSEMBLY INSTRUCTIONS MANUAL DE MONTAGEM / INSTRUCCIONES DE ARMADO

MEENA PANTRY CABINET
PANELEIRO MEENA
DESPENSERO MEENA

Reference
Referência
Referencia

250395

| Revise
| Revisão
| Revisión

00

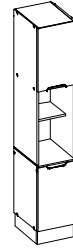

YOU WILL NEED
VOCÊ VAI PRECISAR DE / USTED NECESITARÁ

Tools not supplied
Ferramentas não fornecidas / Herramientas no incluidas

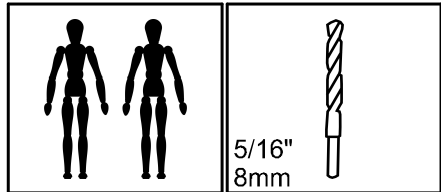

2 People
2 Pessoas
2 Personas

Drill bit
Broca
Taladro

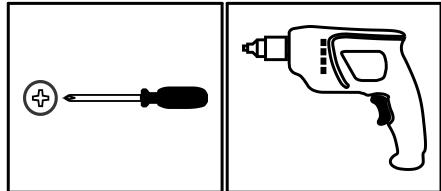

Screwdriver Phillips
Chave Phillips
Destornillador cruz

Drill machine
Furadeira
Taladro

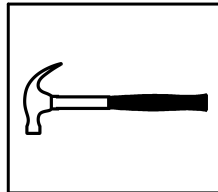

Hammer
Martelo
Martillo

MAXIMUM RECOMMENDED WEIGHT BEING THIS EVENLY DISTRIBUTED.
PESO MÁXIMO RECOMENDADO SENDO ESTE DISTRIBUÍDO UNIFORMEMENTE.
PESO MÁXIMO RECOMENDADO SIENDO ESTE UNIFORMEMENTE DISTRIBUIDO.

	LB	KG
F	22	10

PARTS IDENTIFICATION
IDENTIFICAÇÃO DAS PEÇAS / IDENTIFICACIÓN DE LAS PIEZAS

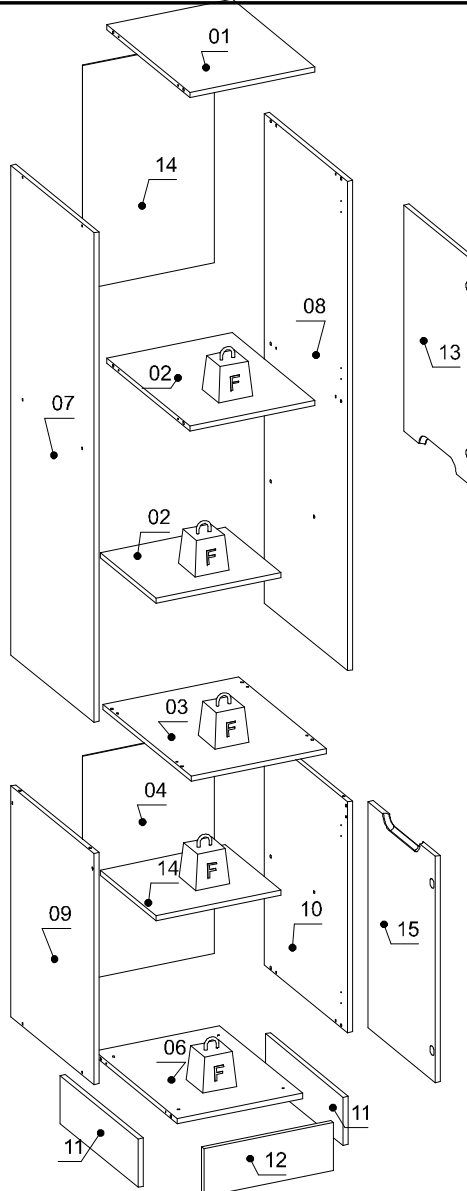

Nº	Measures_Inches	Medidas_cm	Qty./Qtd.
01	14 5/8 x 19 1/4 x 5/8	37.0 x 49.0 x 1.5	1
02	14 5/8 x 19 1/4 x 5/8	37.0 x 49.0 x 1.5	1
03	14 5/8 x 13 x 5/8	37.0 x 33.0 x 1.5	2
04	15 3/4 x 20 1/2 x 5/8	40.0 x 52.0 x 1.5	1
05	14 5/8 x 2 3/8 x 5/8	37.0 x 6.0 x 1.5	2
06	14 5/8 x 19 1/4 x 5/8	37.0 x 49.0 x 1.5	1
07	55 7/8 x 19 1/4 x 5/8	142.0 x 49.0 x 1.5	1
08	55 7/8 x 19 1/4 x 5/8	142.0 x 49.0 x 1.5	1
09	26 3/8 x 19 1/4 x 5/8	67.0 x 49.0 x 1.5	1
10	26 3/8 x 19 1/4 x 5/8	67.0 x 49.0 x 1.5	1
11	18 1/8 x 5 1/2 x 5/8	46.1 x 14.0 x 1.5	2
12	15 1/8 x 5 1/2 x 5/8	38.4 x 14.0 x 1.5	1
13	25 7/8 x 15 5/8 x 5/8	65.6 x 39.7 x 1.5	1
14	25 5/8 x 15 3/8 x 1/8	65.0 x 39.0 x 0.3	2
15	25 7/8 x 15 5/8 x 5/8	65.6 x 39.7 x 1.5	1

IDENTIFICATION OF ACCESSORIES IDENTIFICAÇÃO DOS ACESSÓRIOS/ IDENTIFICACIÓN DE ACCESORIOS



The separation of the accessories before you start the assembly will facilitate the same. In case of doubt on the size of the screws and bolts, use the ruler at the bottom of the page.
 A separação dos acessórios antes de iniciar a montagem facilitará a mesma. Em caso de dúvida no tamanho dos parafusos e cavilhas, utilize a régua ao final da página.
 La separación de los accesorios antes de comenzar el armado facilitará el mismo. En caso de duda sobre el tamaño de los tornillos y taquetes, utilice la regla al pie de página.

A		Flanged head screw Parafuso flangeado / Tornillo de cabeza flangeada	5,0x60 mm	2
A4		Metalic bracket Cantoneira de metal / Suporte de metal	22x22 mm	6
A23		Foot Pé Quadrado FP / Pie	140 mm	4
B3		Bushing Bucha expansiva / Tapón	8x50 mm	2
C		Flanged head screw Parafuso flangeado / Tornillo de cabeza flangeada	4,5x45 mm	4
D5		Hinge shim Calço dobradiça / Bisagra de calce	-	4
E		Wooden dowel Cavilha / Taquete	8x30 mm	16
E3		Shelf bracket Suporte de prateleira / Suporte de repisa	8x7 mm	8
F		Wooden dowel Cavilha / Taquete	8x50 mm	4
F9		Metal hinge straight Dobradiça reta / Bisagra recta	26 mm	4
K26		Handle Puxador Cava / Tirador	160 mm	2
M		Bore patch adhesive Tapa furo adesivo / Tapones adhesivo	-	16
N		Nail Prego / Clavo	10x10	40
N5		Support "L" Suporte "L" / Soporte "L"	-	2
O		Flat head screw Parafuso chato / Tornillo de cabeza plana	4,5x45 mm	20
S		Pan head screw Parafuso panela / Tornillo de pan	3,5x14 mm	46
Y18		Zamac bracket Cantoneira zamac/ Suporte de zamac	13x13 mm	4

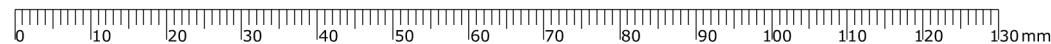

PRE-ASSEMBLE PRÉ-MONTAGEM / PRE ARMADO

01

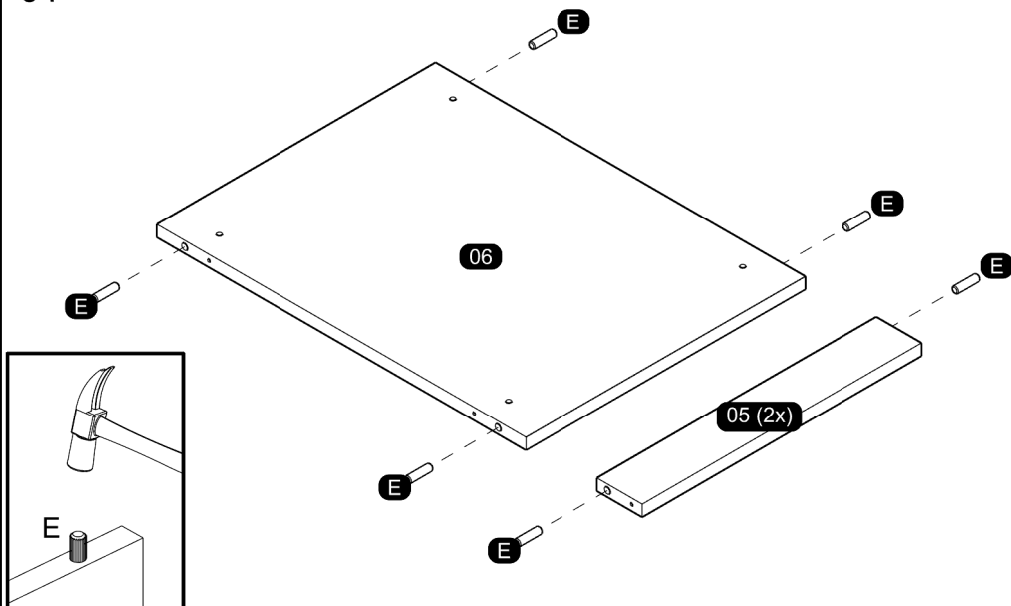

02

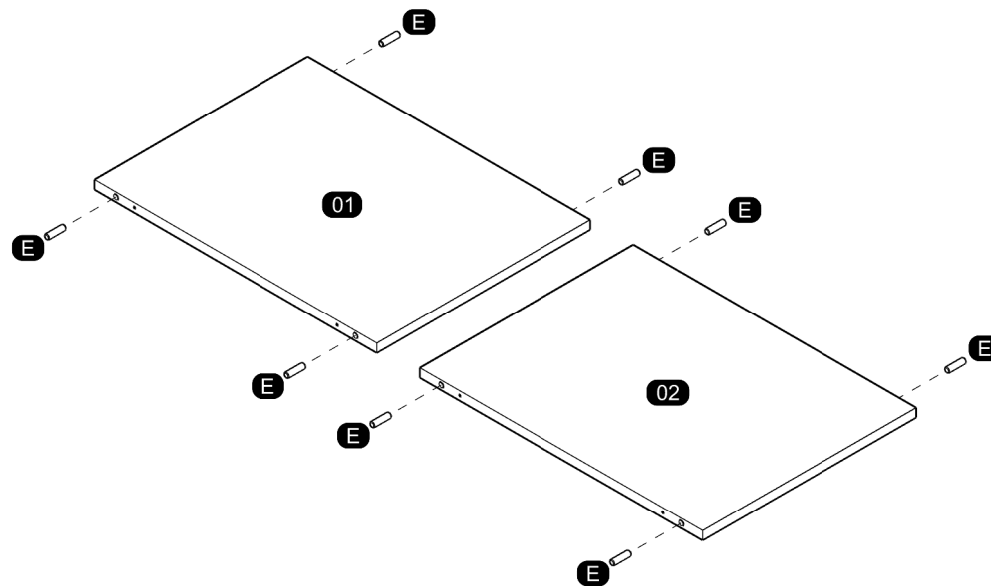

03

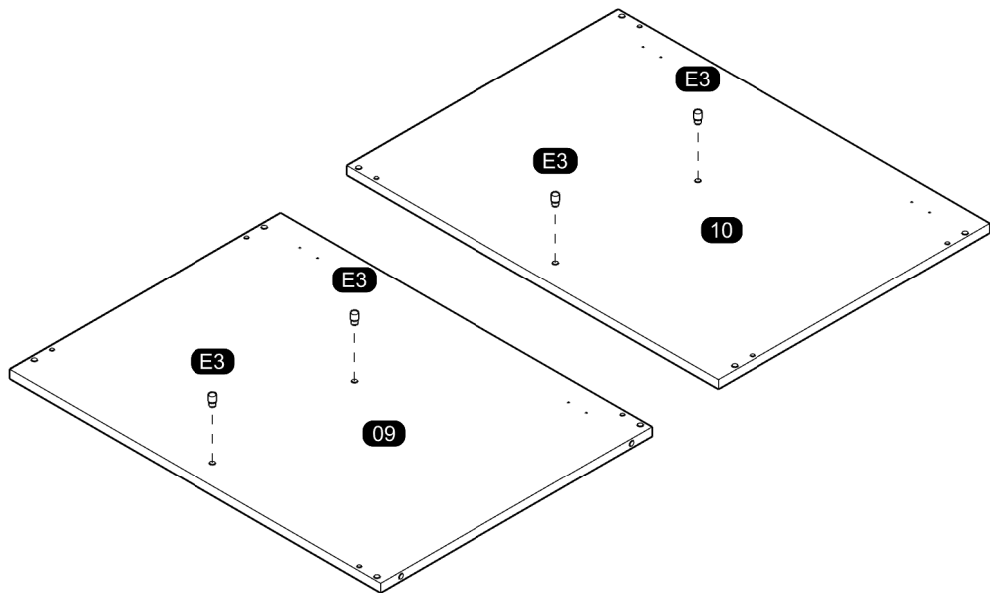

05

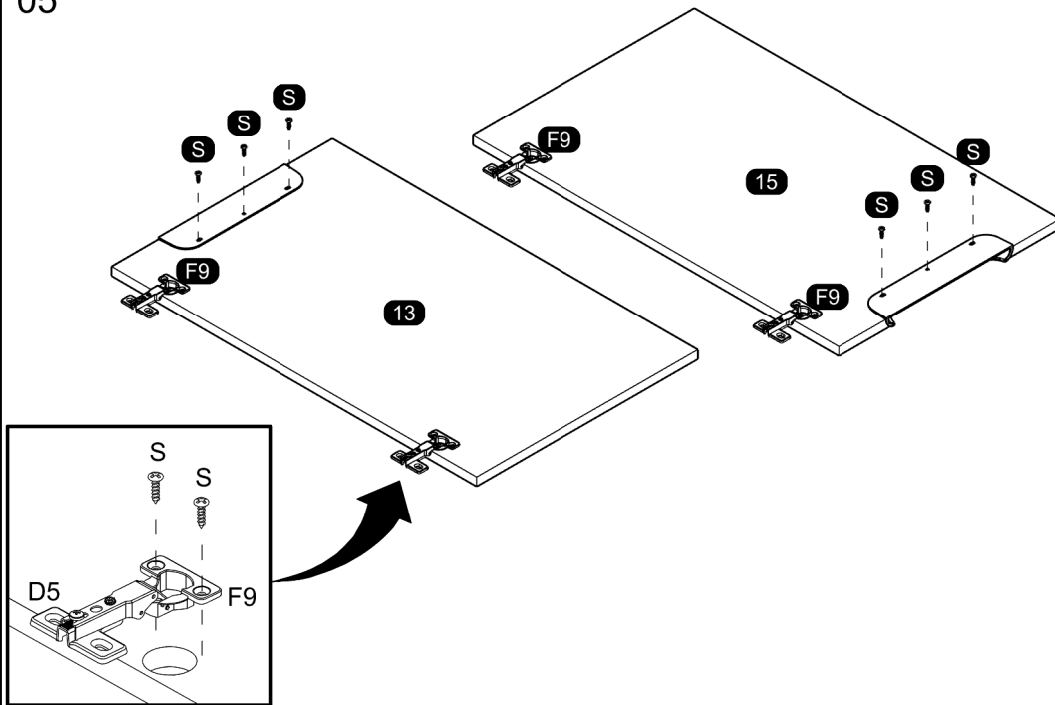

04

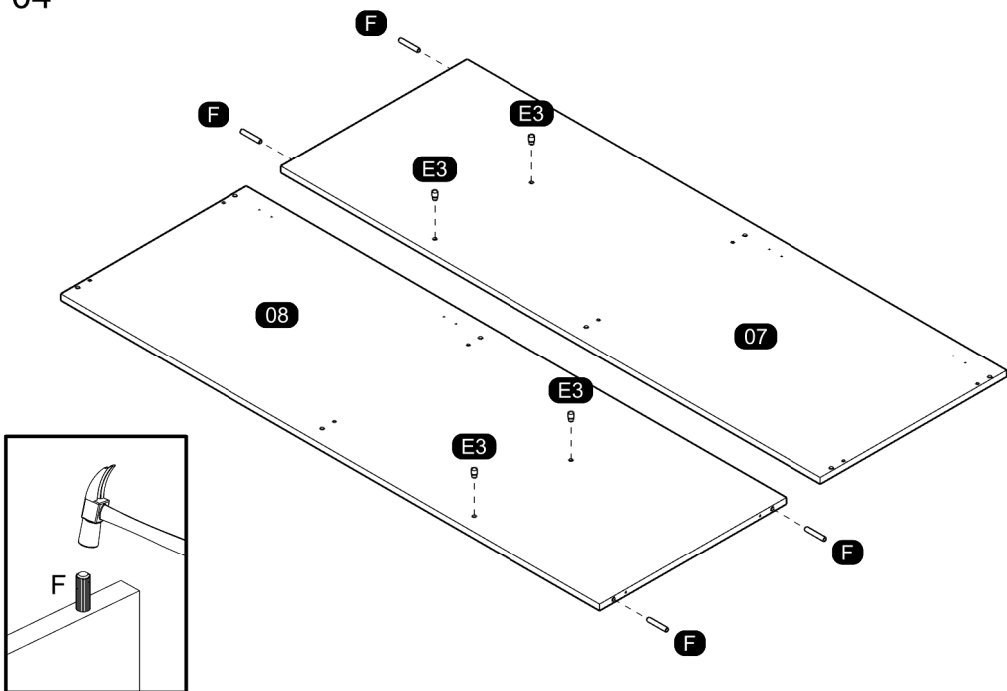

**ASSEMBLY
MONTAGEM / ARMADO**

06

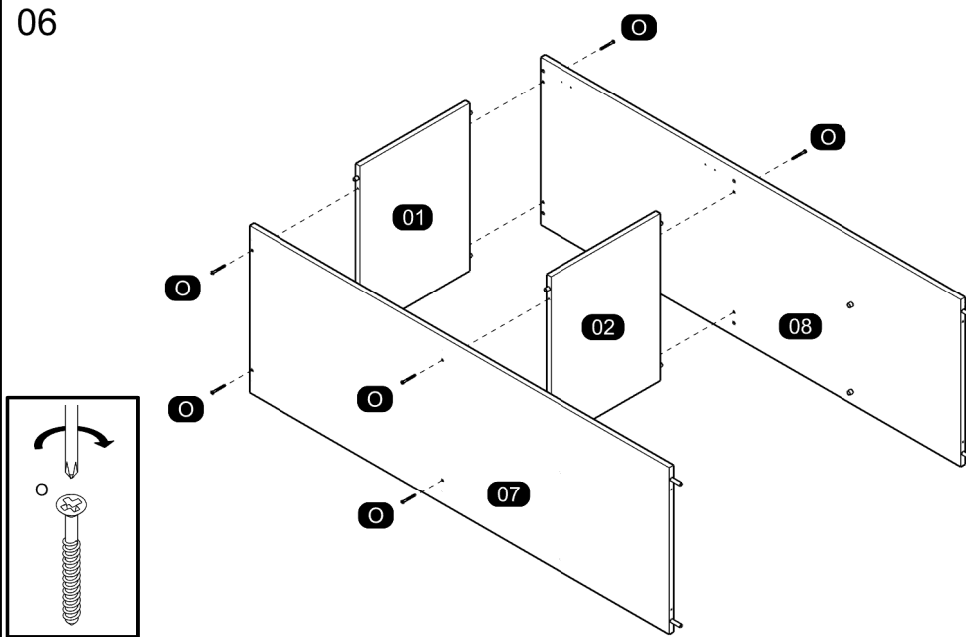

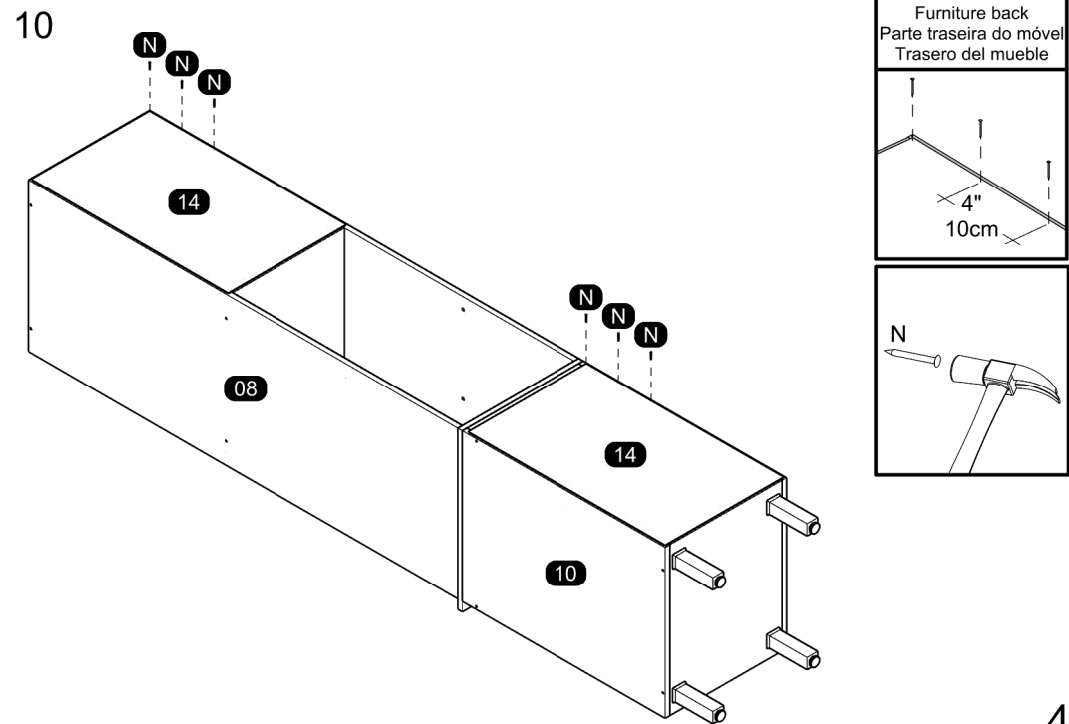
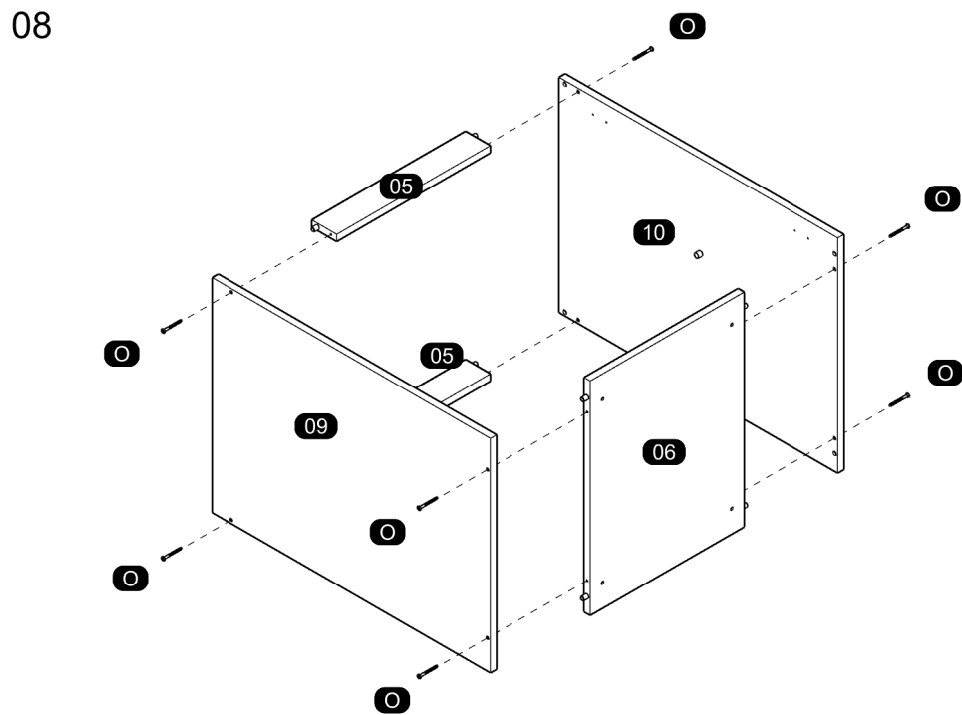
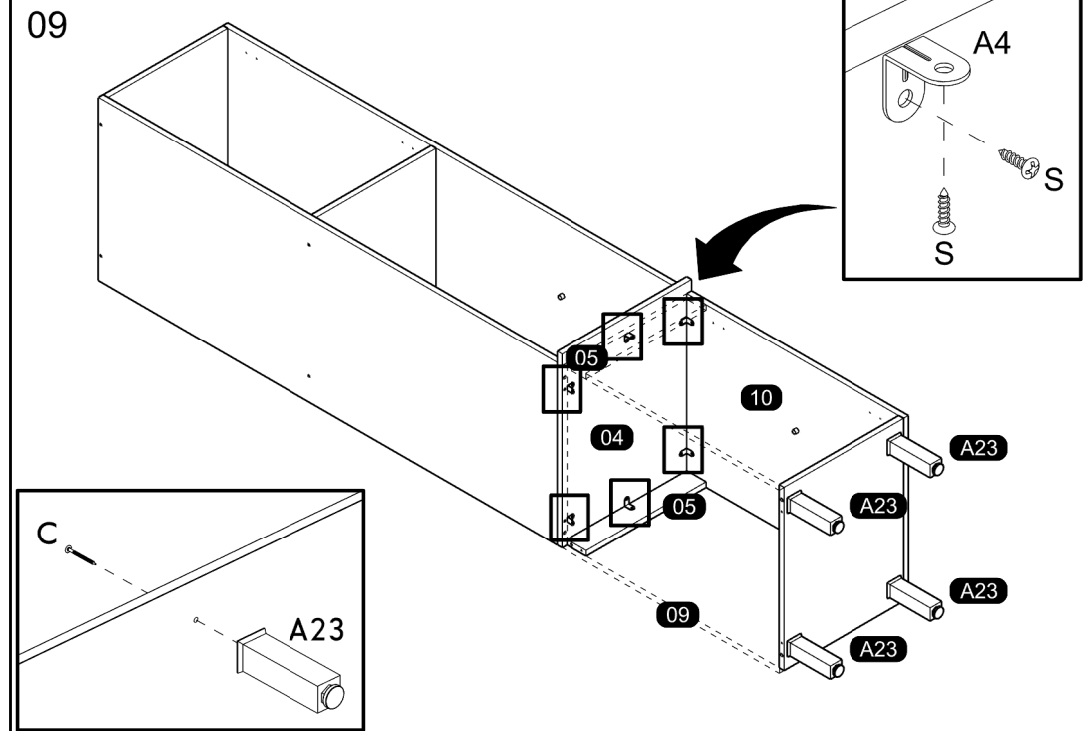
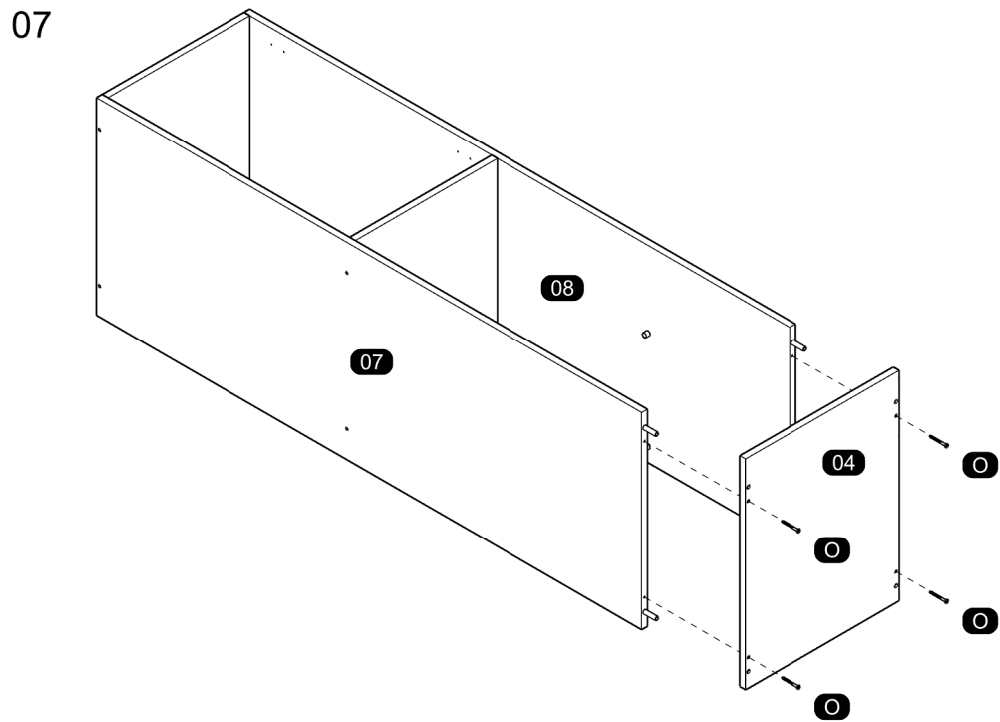

11

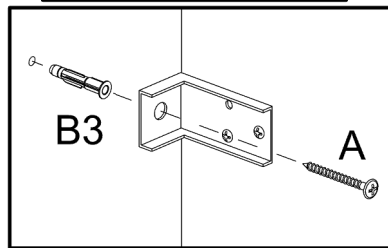
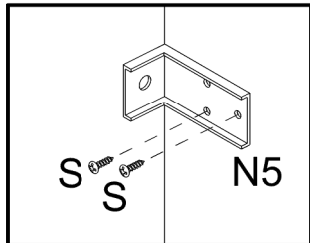
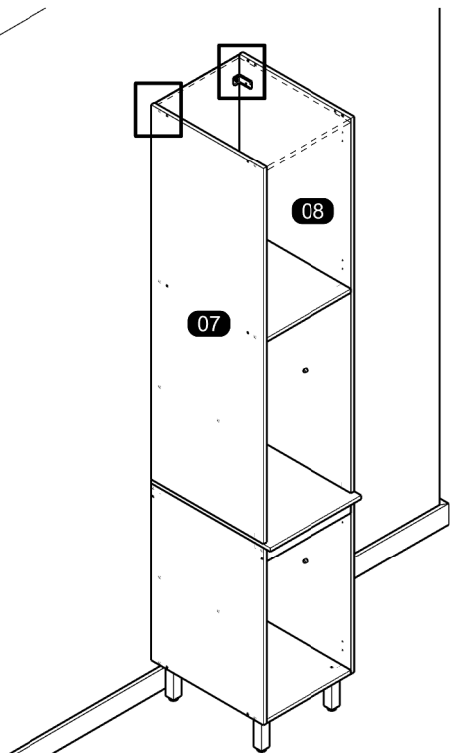

13

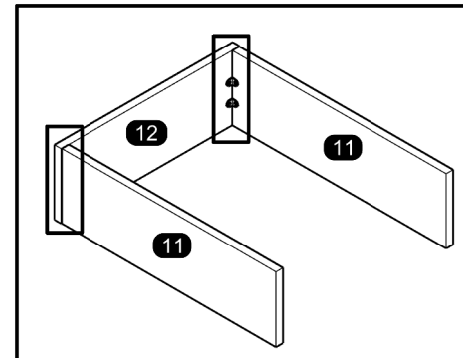
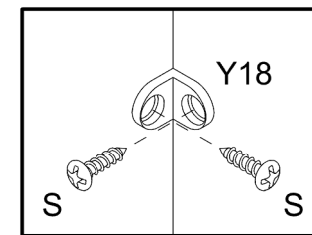
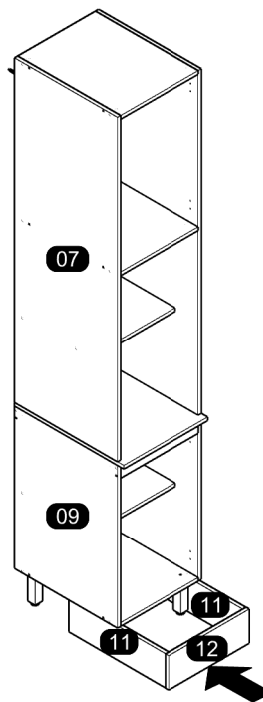

12

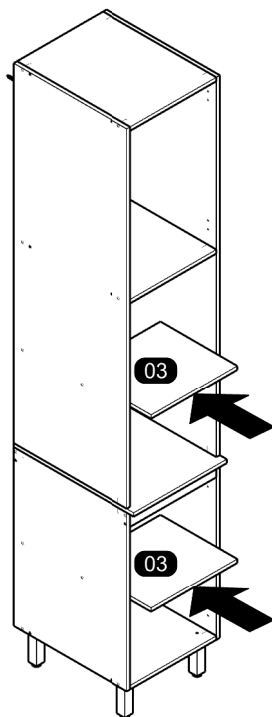

14

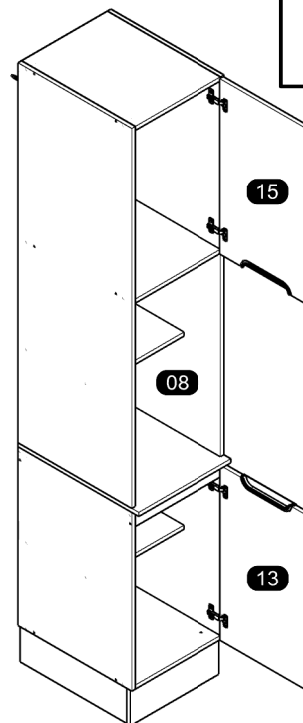

DOOR MOUNTING RIGHT SIDE
MONTAGEM DA PORTA LADO DIREITO
MONTAJE DE LA PUERTA LADO DERECHO

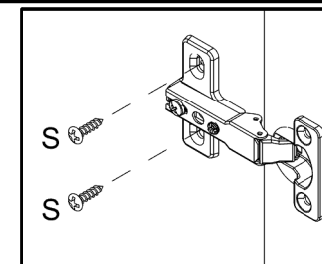

15

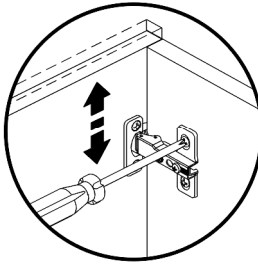
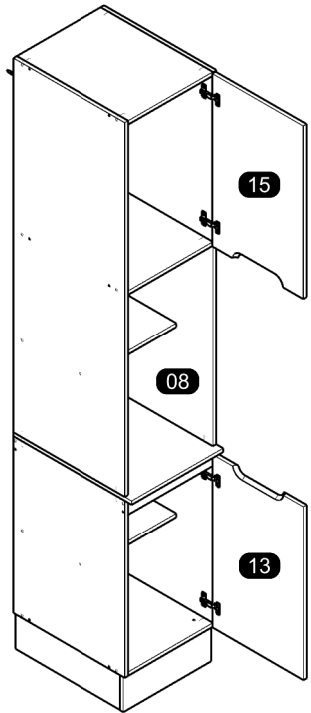

Vertical Adjustment
Regulagem Vertical
Ajuste Vertical

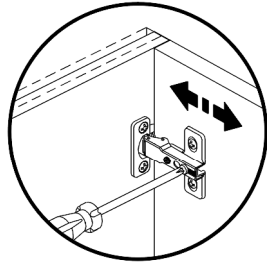

Depth Adjustment
Regulagem Profundidade
Ajuste Profundidad

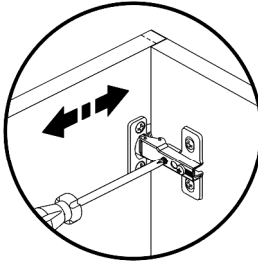

Horizontal Adjustment
Regulagem Horizontal
Ajuste Horizontal

17

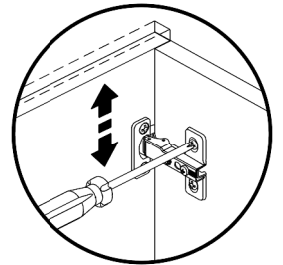
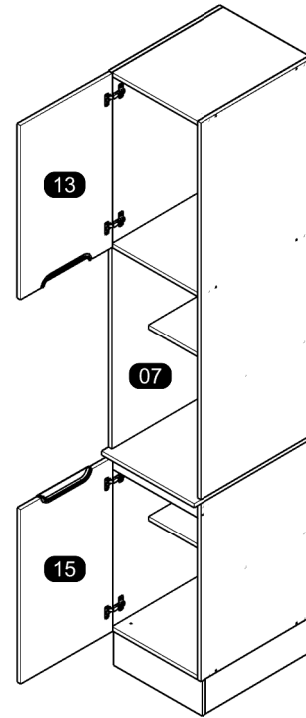

Vertical Adjustment
Regulagem Vertical
Ajuste Vertical

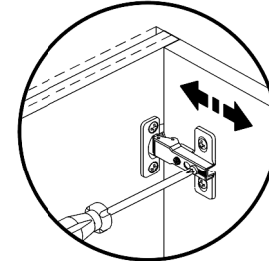

Depth Adjustment
Regulagem Profundidade
Ajuste Profundidad

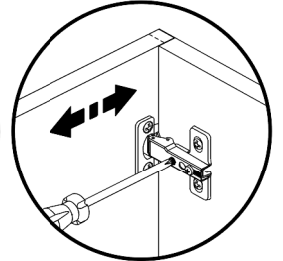

Horizontal Adjustment
Regulagem Horizontal
Ajuste Horizontal

16

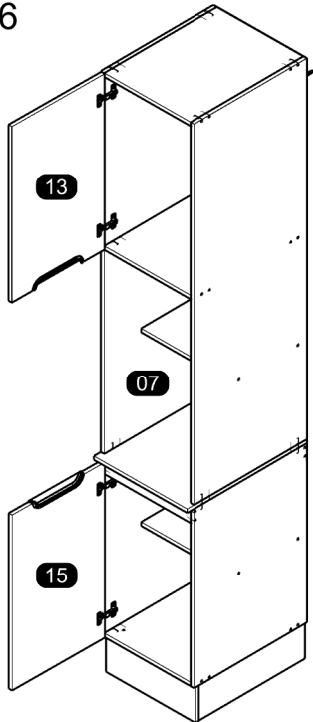

**DOOR MOUNTING LEFT SIDE
MONTAGEM DA PORTA LADO ESQUERDO
MONTAJE DE LA PUERTA LADO IZQUIERDO**

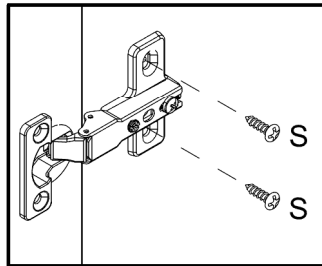

18

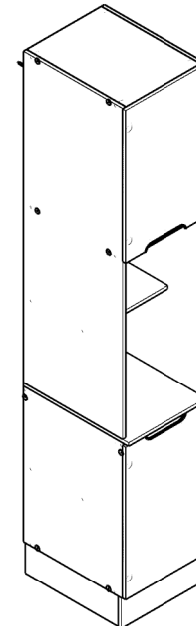

At the end of the assembly, insert the screw cover / hole plugs in the apparent holes.
Ao final da montagem, insira a(s) tampa(s) de parafuso / tapa furos nos furos que ficarem aparentes.
Al final del conjunto, coloque la tapa tornillo / tapón plástico en los agujeros que se hagan evidentes.