

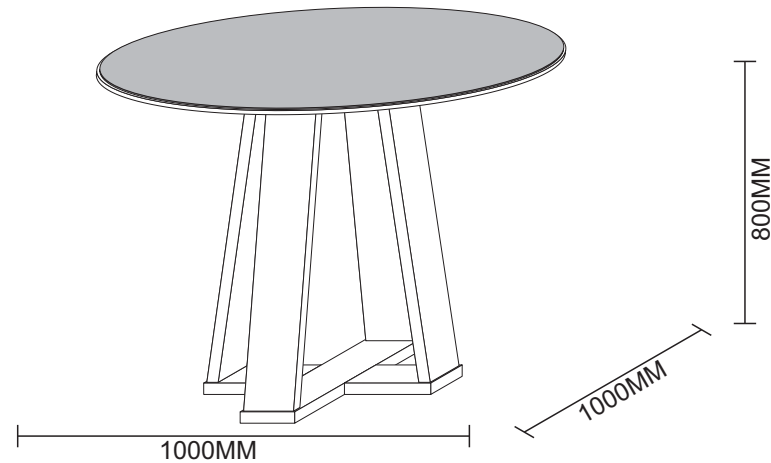

Nova linha, mesma qualidade.



Manual de montagem

Caro montador !!!

Para uma melhor montagem de nosso produto siga as seguintes instruções:

- Retire todas as peças da caixa e identifique-as;
- Separe e confira todos os acessórios;
- Deixe as peças em pé, nunca as deixe colocando umas sobre as outras;
- Utilize a própria embalagem como tapete para a montagem;

Assembly instructions

Dear Assembler !!!

For a better assembly of our products follow the instructions below:

- Remove all parts from the box and identify them;
- Separate and check all accessories;
- Leave the pieces upright, never lay them on top of each other;
- Use the packaging itself as a carpet for assembly;

Instrucciones de montaje

Estimado Armador !!!

Para un mejor montaje de nuestros productos sigue las instrucciones de abajo:

- Saque todas las piezas de la caja e identifíquelas;
- Separe y revise todos los accesorios;
- Deje las piezas en posición vertical, nunca las coloque una encima de la otra;
- Utilizar el propio embalaje como alfombra para el montaje.

Acessórios

Accessories

Accesorios

A	Cod. 0086 Paraf. Panela 3,5 x 25mm - 08un	B	Cod. 0095 Paraf. 5.0x60mm Extrutural - 16un	C	Cod. 0824 Paraf. Panela 3,5 x 12mm - 16un	D	Cod. 0056 Chapa de União - 02un	E	Cod. 0102 Sapata com regulagem - 04un	F	Cod. 0052 Cavilha 10x40 madeira - 04un	G	Cod. 0099 Sache de cola - 01un
----------	---	----------	---	----------	---	----------	------------------------------------	----------	--	----------	---	----------	-----------------------------------

Ferramentas utilizadas para a montagem

Tools used for assembly

Herramientas utilizadas para el montaje

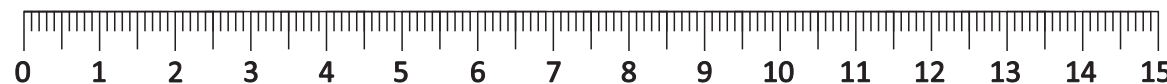
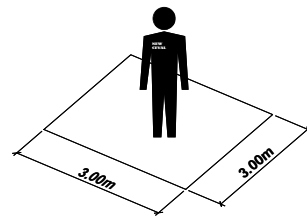

Av. Arvelino Durante, 1700 - Parque Industrial III - Sabáudia - Paraná - Brasil - Fone/Fax: (43) 3151-1740 - CEP: 86720-000

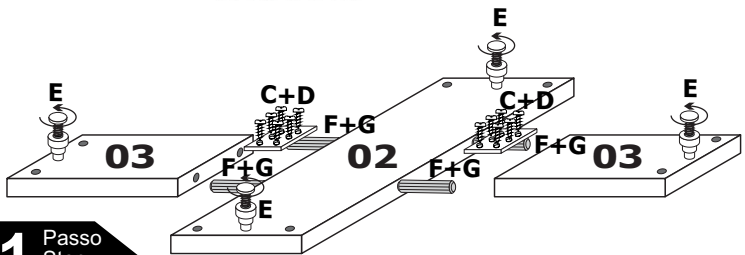

1 Passo
Step
Paso

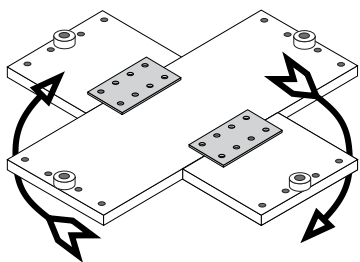

Obs.: Vire a base para baixo de maneira que as chapas de união fiquem voltada para o chão após o termino da montagem.

Note: Turn the base downwards so that the union plates are facing the floor after finishing the assembly.

Nota: Gire la base hacia abajo para que las placas de unión de cara al suelo después de terminar el montaje.

2 Passo
Step
Paso

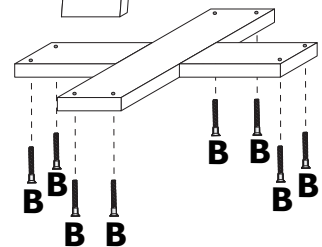
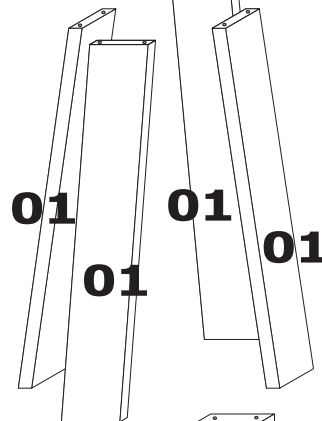
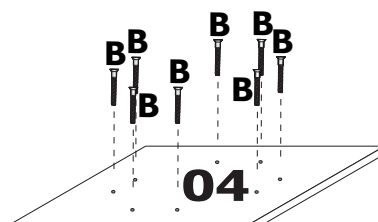

3 Passo
Step
Paso

Ref.	Cód.: Fabrica	Descrição	Qtde
01	2301701	Lateral	04
02	2301702	Base Maior	01
03	2301703	Base Menor	02
04	2301704	Suporte do Tampo	01
05	230852	Tampo c/ Vidro	01

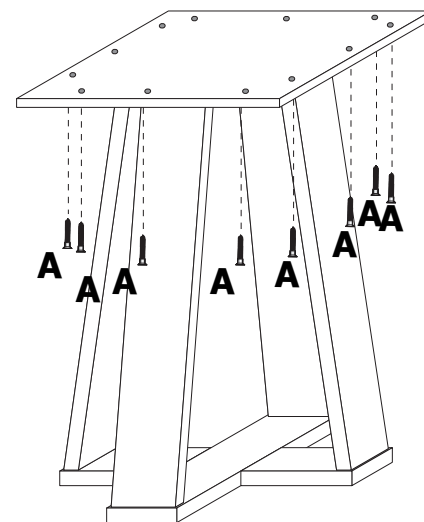



Nova linha, mesma qualidade.

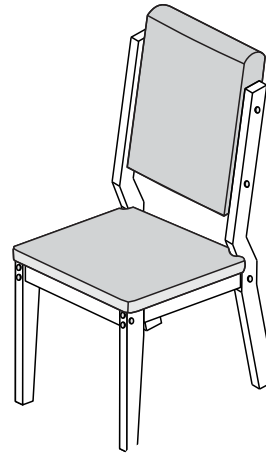

Manual de montagem

Caro montador !!!

Para uma melhor montagem de nosso produto siga as seguintes instruções:

- Retire todas as peças da caixa e identifique-as;
- Separe e confira todos os acessórios;
- Deixe as peças em pé, nunca as deixe colocando umas sobre as outras;
- Utilize a própria embalagem como tapete para a montagem;

Assembly instructions

Dear Assembler !!!

For a better assembly of our products follow the instructions below:

- Remove all parts from the box and identify them;
- Separate and check all accessories;
- Leave the pieces upright, never lay them on top of each other;
- Use the packaging itself as a carpet for assembly;

Instrucciones de montaje

Estimado Armador !!!











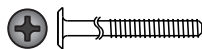
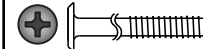

Para un mejor montaje de nuestros productos sigue las instrucciones de abajo:

- Saque todas las piezas de la caja e identifíquelas;
- Separe y revise todos los accesorios;
- Deje las piezas en posición vertical, nunca las coloque una encima de la otra;
- Utilizar el propio embalaje como alfombra para el montaje.

Acessórios

Accessories

Accesorios

A Cod. 0080  Paraf. 1/4"x70mm - 04un	B Cod. 0077  Paraf. 1/4"x100mm - 08un	C Cod. 0082  Paraf. Flang. 3,5 x 12mm - 32un	D Cod. 0045  Cantoneira metal - 04un	E Cod. 0306  Tamp. Plás. Paraf. 1/4 - 12un	F Cod. 0095  Paraf. 5,0x60mm Estrutural - 04un	G Cod. 0097  Porca Cilíndrica 12x12 - 12un
H Cod. 0053  Cavilha 8x30 madeira - 04un	I Cod. 0199  Tamp. Furo Ades. - 04un	J Cod. 0101  Sapata Redonda- 04un	K Cod. 0098  Prego 10 x 10 - 04un	L Cod. 0057  Cantoneira de metal - 04un	M Cod. 0343  Arruela lisa 1/4 - 12un	

Ferramentas utilizadas para a montagem

Tools used for assembly

Herramientas utilizadas para el montaje

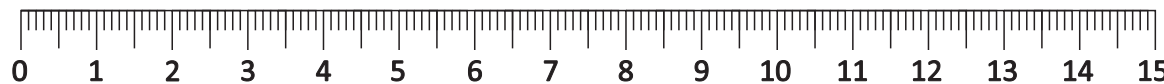
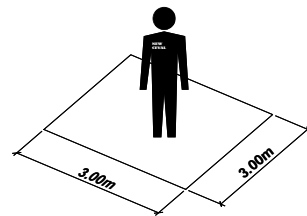

Av. Arvelino Durante, 1700 - Parque Industrial III - Sabáudia - Paraná - Brasil - Fone/Fax: (43) 3151-1740 - CEP: 86720-000



Assista o vídeo da montagem da cadeira através de nosso QR CODE!

Watch the video chair assembly through our QR CODE!

Ver el vídeo montaje de silla a través de nuestro QR CODE!

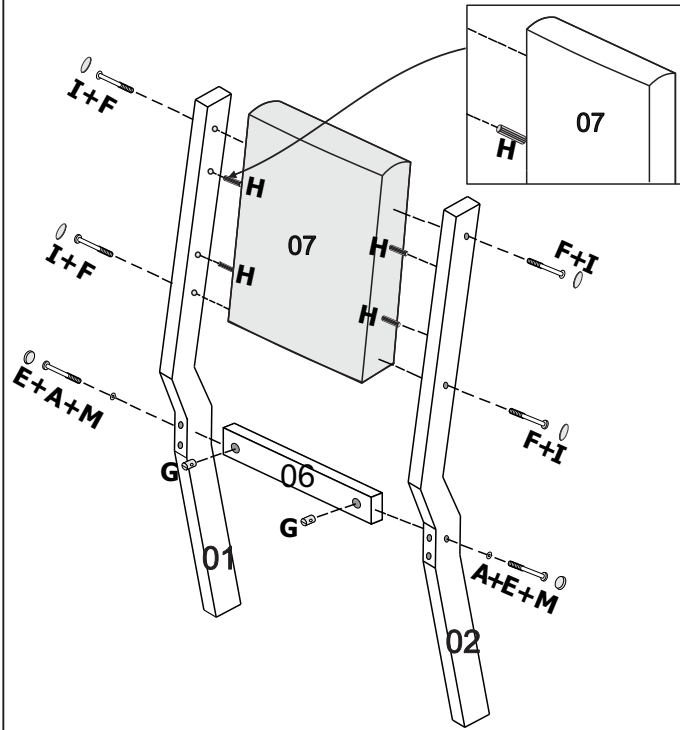

1 Passo
Step
Paso

IMPORTANTE:
LADO RETO DO PE
PARA FRENTE DA CADEIRA.

IMPORTANT:
STRAIGHT SIDE OF PE
TOWARDS THE CHAIR.

IMPORTANTE:
LADO RECTO DE PE
HACIA LA SILLA.

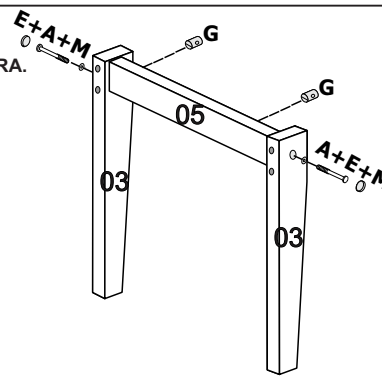

2 Passo
Step
Paso

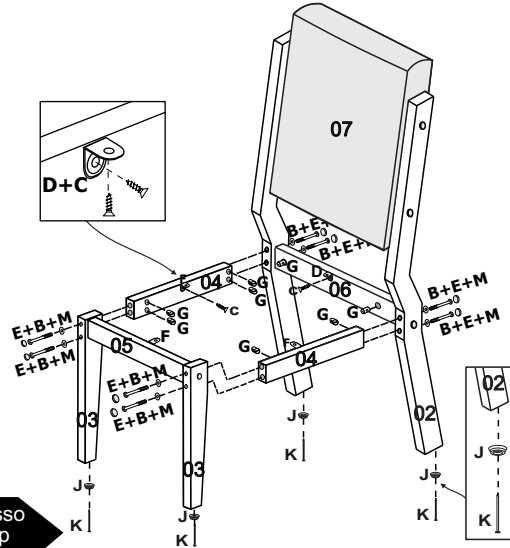

3 Passo
Step
Paso

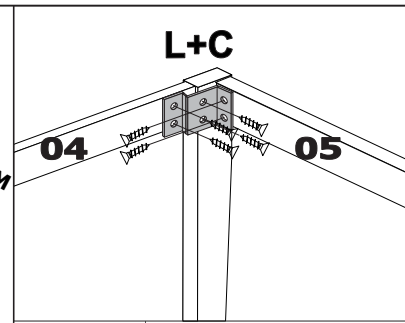

4 Passo
Step
Paso

Ref.	Cód.: Fabrica	Descrição	Qtde
01	1300601	Pé Maior Esquerdo	01
02	1300602	Pé Maior Direito	01
03	1300603	Pé Menor	02
04	1300604	Barra Lateral	02
05	1300605	Barra Frontal	01
06	1300606	Barra Traseira	01
07	1300607	Encosto	01
08	1300609	Assento	01

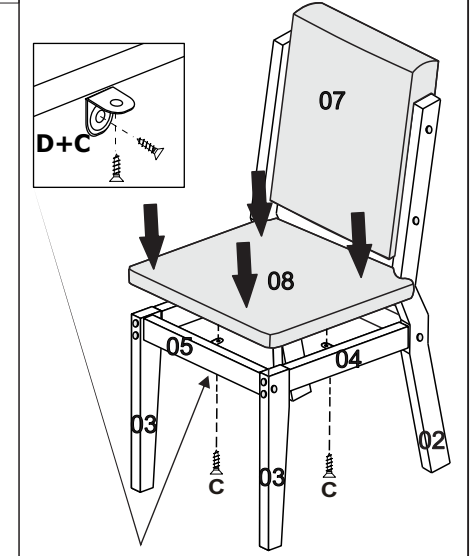

5 Passo
Step
Paso