

emovell

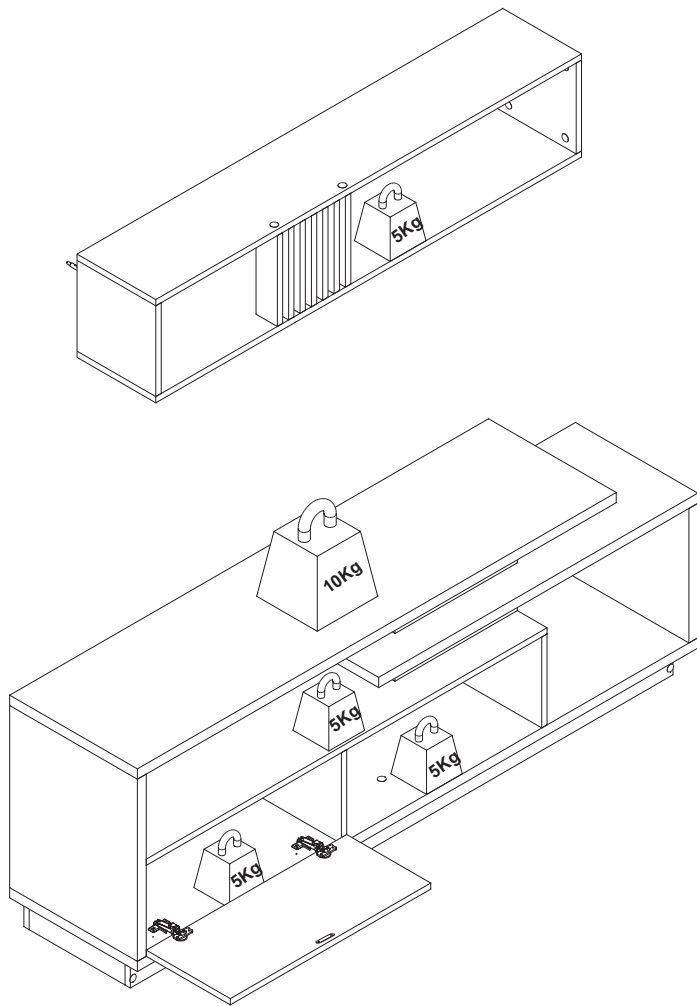

PESO MÁXIMO SUPORTADO
MAXIMUM WEIGHT SUPPORTED
PESO MAXIMO SOPORTADO

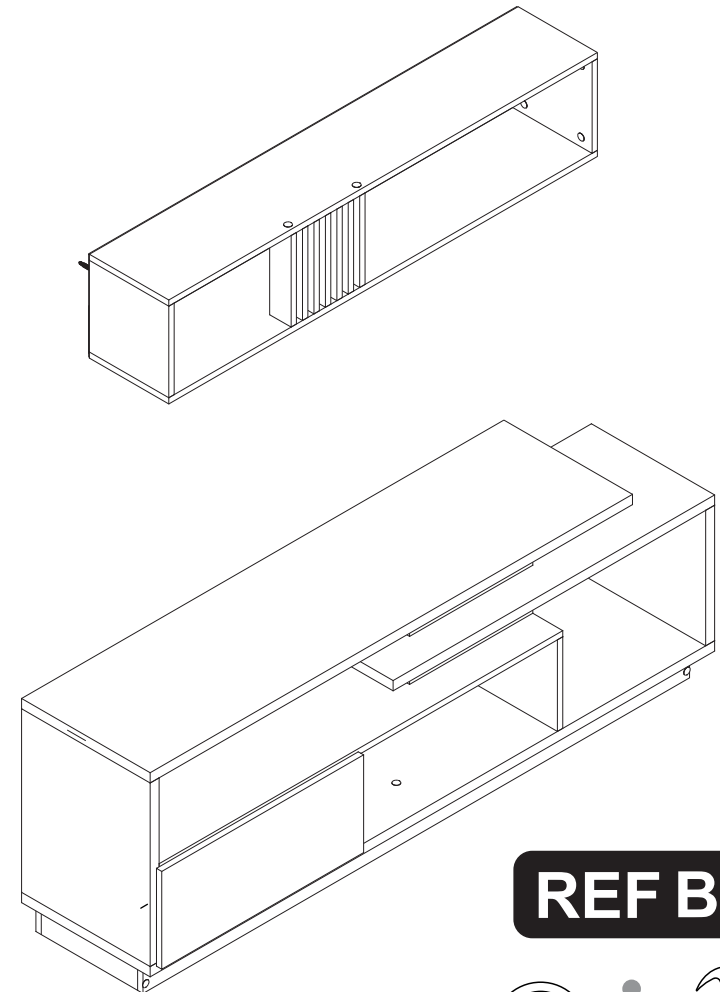

REF B152

Item não acompanha ferramenta de montagem
Item does not come with mounting tool
El artículo no viene con la herramienta de montaje

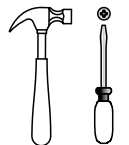

Manutenção e Limpeza:

Use pano levemente umedecido com água, seguido de pano seco. Nunca utilize produtos químicos ou abrasivos.

Maintenance and Cleaning:

Use a cloth slightly dampened with water, followed by a dry cloth. Never use chemicals or abrasives.

Mantenimiento y limpieza:

Use un paño ligeramente humedecido con agua, seguido de un paño seco. Nunca use productos químicos o abrasivos.

Rua José Benediti, nº 1620, Pavilhão C - Fone: +55 (054) 2108-8400 - +55 (054) 99614-6360

CEP: 95706-500 - Bento Gonçalves - RS - Site: www.emovell.com.br - E-mail: comercial@emovell.com.br

FERRAGENS / HARDWARE LIST / LISTA DE HERRAJES



ATENÇÃO!!!











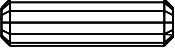







Em caso de uso de parafusadeira comece com um torque bem leve e vá aumentando até achar o ideal. Aperte somente até travar. Torque excessivo pode espanar o parafuso e danificar a peça comprometendo sua correta fixação.

ATTENTION!!!

If using a screwdriver, start with a very light torque and increase until you find the ideal. Press only until it locks. Excessive torque can strip the bolt and damage the part, compromising its correct fixation.

ATENCIÓN!!!

En caso de utilizar un destornillador, comience con un torque muy ligero y vaya aumentando hasta encontrar el ideal. Presione solo hasta que se detener. Torsión excesivo puede desempolvar el tornillo y dañar la pieza, comprometiendo su correcta fijación.

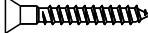
LOC.	IMAGEM / IMAGE / IMAGEN	QUANTIDADE # OF PIECES CANTIDAD
A	 8x30mm	76
B	 8,0x60mm	02
C		24
D		02
E	 3,5x14mm	08
F		04
G		10
H	 4,0x50mm	12
I		24
J		40
K	 4,0x40mm	12
L		08
M	 3,5x14mm	24
N	 3,0x10mm	02
O		40
P		01
Q	 5,0x60mm	02
R		02
S		02
T	 4,0x25mm	04

13

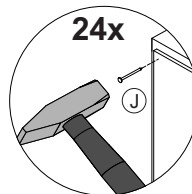

24x

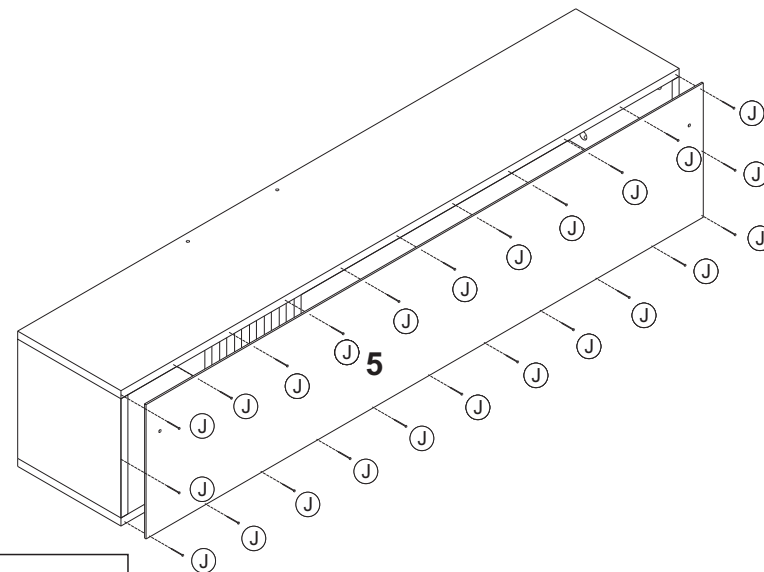

J (20x)

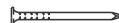

14

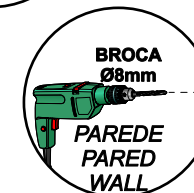
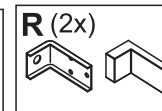
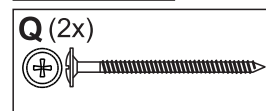
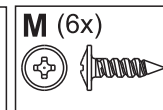
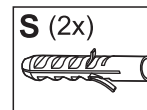
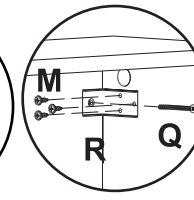
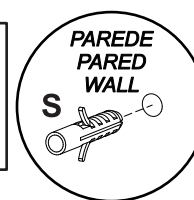
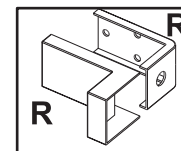
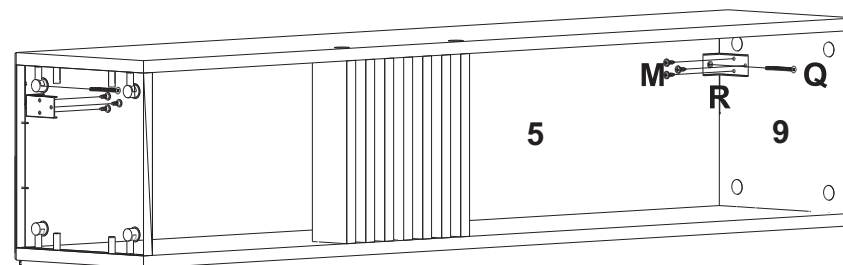

11

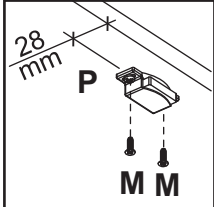
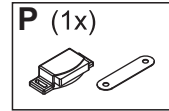
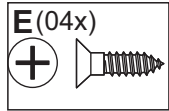
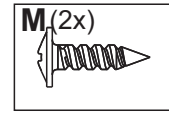
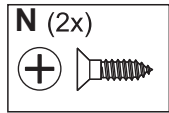
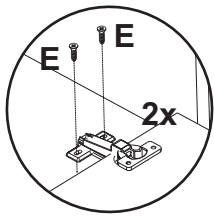
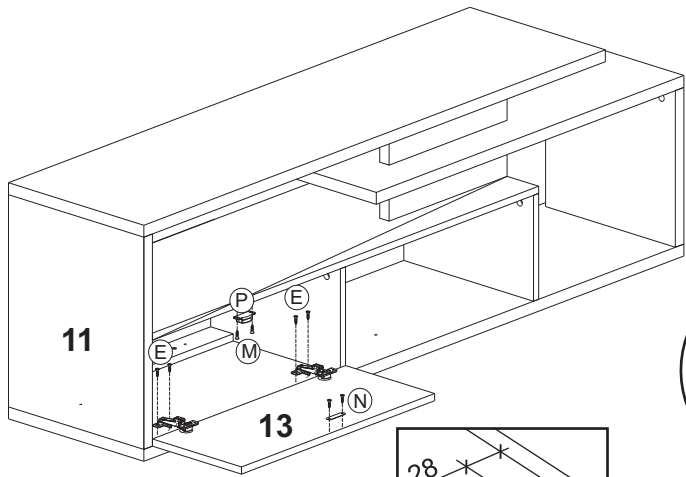
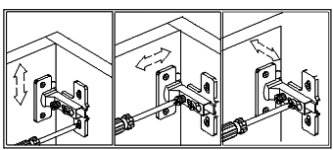

12

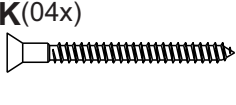
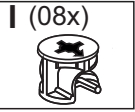
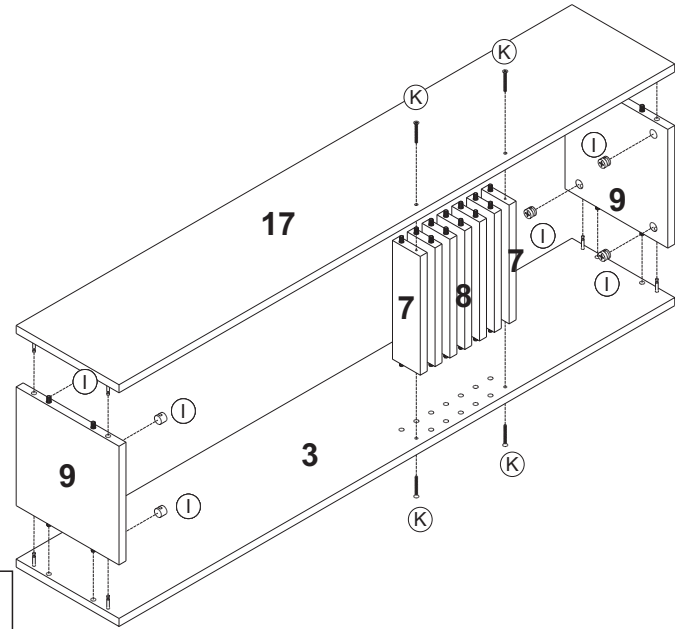

PARTES DO PRODUTO / PRODUCT PARTS / PARTES DEL PRODUCTO

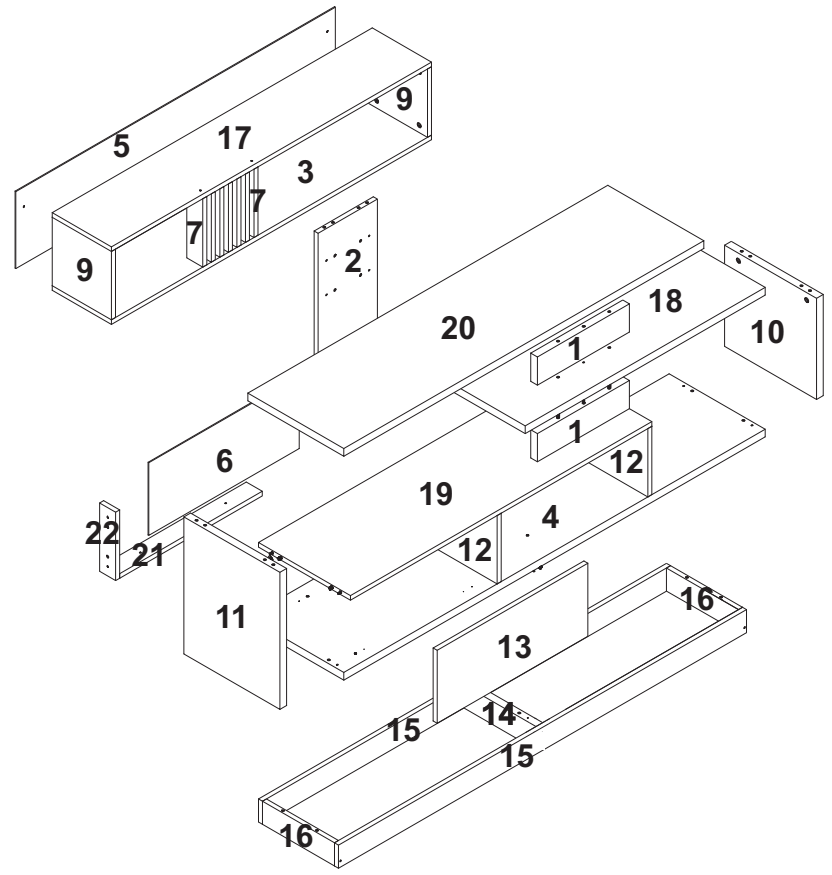

COD	DESCRIÇÃO/DESCRIPTION/DESCRIPCIÓN	DIM	QTD.
1	APOIO DIANT\FRONT SUPPORT\SOPORTE DELANTERO	91,5 X 345 X 25 mm	2
2	APOIO TRAS\BACK SUPPORT\SOPORTE TRASERO	445 X 222 X 15 mm	1
3	BASE AEREO\AIR BASE\BASE AEREA	1200 X 222 X 15 mm	1
4	BASE RACK\BASE RACK\BASE RACK	1580 X 360 X 25 mm	1
5	COSTA AEREO\AIR BACK\TRASERO ARRIBA	1198 X 252 X 3 mm	1
6	COSTA RACK\BACK RACK\TRASERO RACK	564 X 236 X 3 mm	1
7	DET AEREO\AIR DETAIL\DETALLE AEREO	222 X 60 X 15 mm	2
8	DET AEREO CENTRAL\AIR DET CENTER\DETALLE AEREO CENTRAL	222 X 60 X 15 mm	5
9	LAT AEREO\AIR SIDE\LADO AEREO	222 X 222 X 15 mm	2
10	LAT DIR RACK\RACK RIGHT SIDE\LADO DERECHO RACK	328,5 X 345 X 25 mm	1
11	LAT ESQ RACK\RACK LEFT SIDE\LATERAL IZQUIERDO RACK	445 X 360 X 25 mm	1
12	LAT NICHOS RACK\LAT NICHE RACK\LADO NICHOS RACK	345 X 222 X 15 mm	2
13	PORTA\DOOR\PUERTA	565 X 237 X 15 mm	1
14	RODAPE CENTRAL\CENTER BASEBOARD\ZOCALO CENTRAL	270 X 75 X 25 mm	1
15	RODAPE MAIOR\BIGGGER BASEBOARD\ZOCALO MAS GRANDE	1530 X 75 X 15 mm	2
16	RODAPE MENOR\SMALLER BASEBOARD\ZOCALO MAS PEQUEÑO	270 X 75 X 15 mm	2
17	TAMPO AEREO\AIR TOP\TAPA AEREA	1200 X 222 X 15 mm	1
18	TAMPO INTERM\INTERMED TOP\TAPA INTERMEDIARY	900 X 345 X 25 mm	1
19	TAMPO NICHOS RACK\RACK NICHE TOP\TAPA NICHE RACK	1130 X 345 X 15 mm	1
20	TAMPO SUP\UPPER TOP\TAPA ARRIBA	1350 X 360 X 25 mm	1
21	TRAV TRAS INF\LOWER BACK CROSSBAR\TRASENÕ TRASERO ABAJO	535 X 60 X 15 mm	1
22	TRAV TRAS LAT\BACK SIDE CROSSBAR\LADO TRASENÕ TRASERO	222 X 60 X 15 mm	1

1

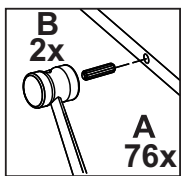
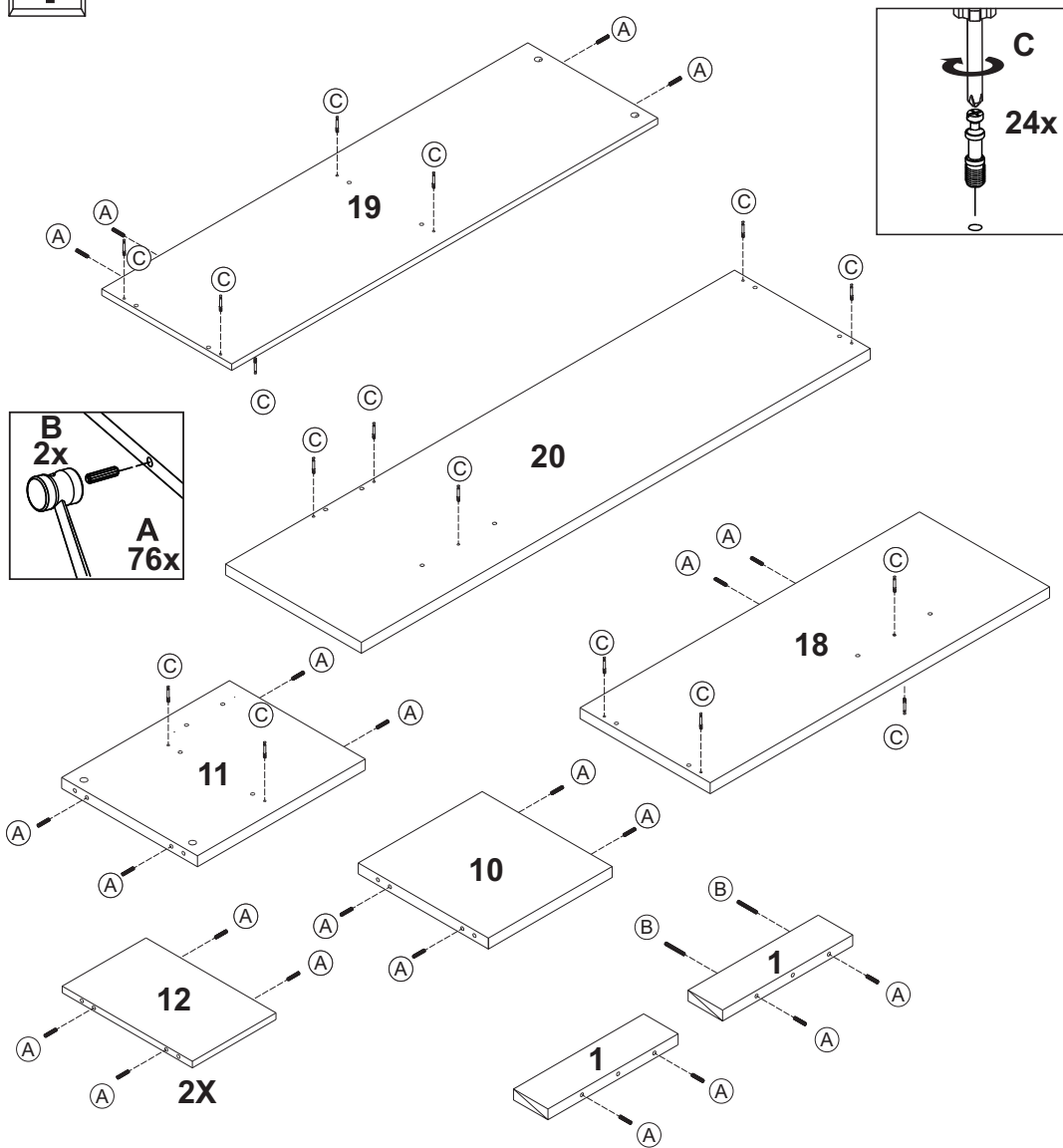

9

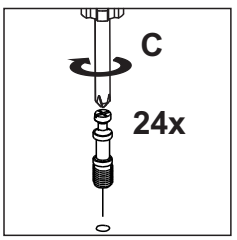

10

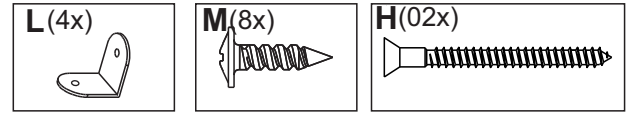
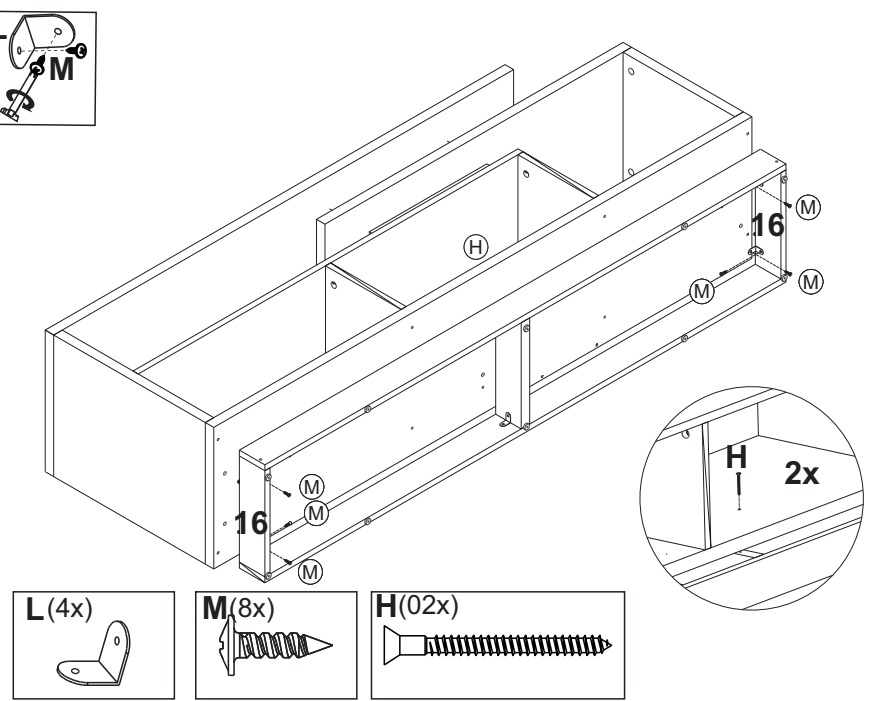
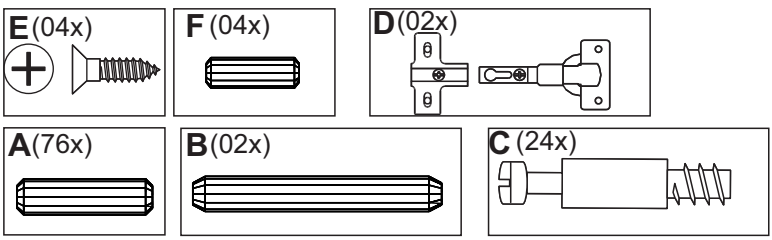
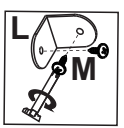
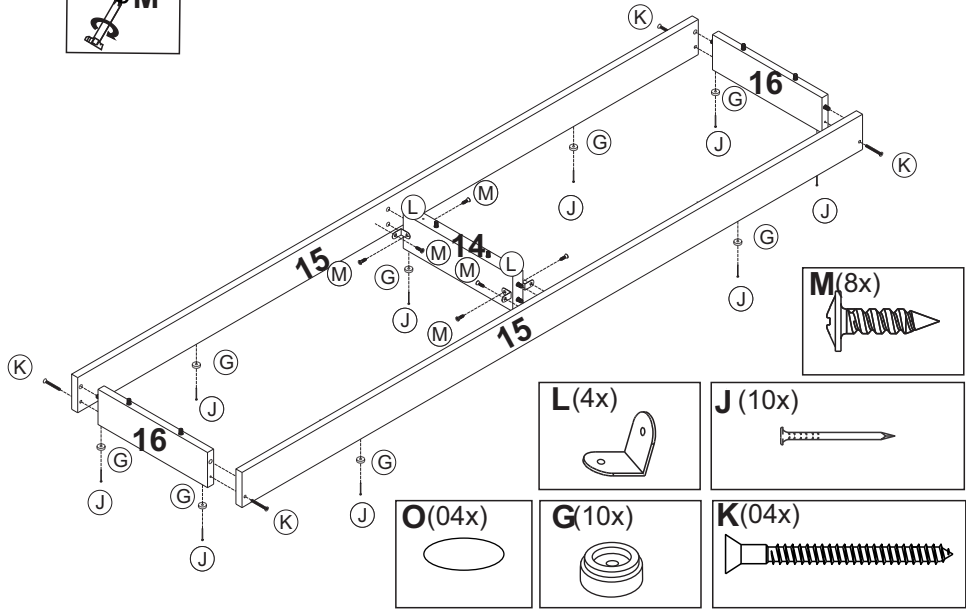

7

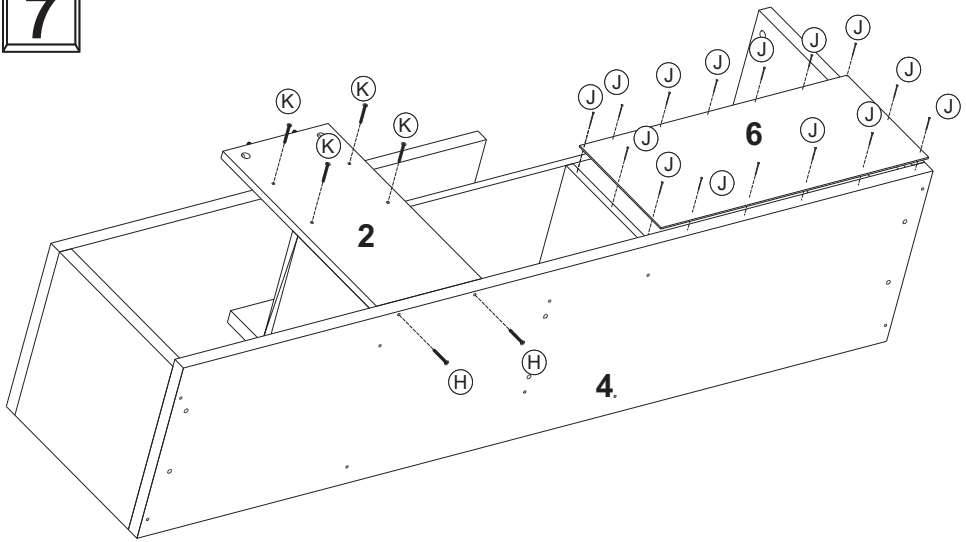

2

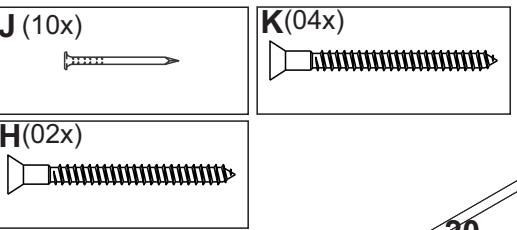
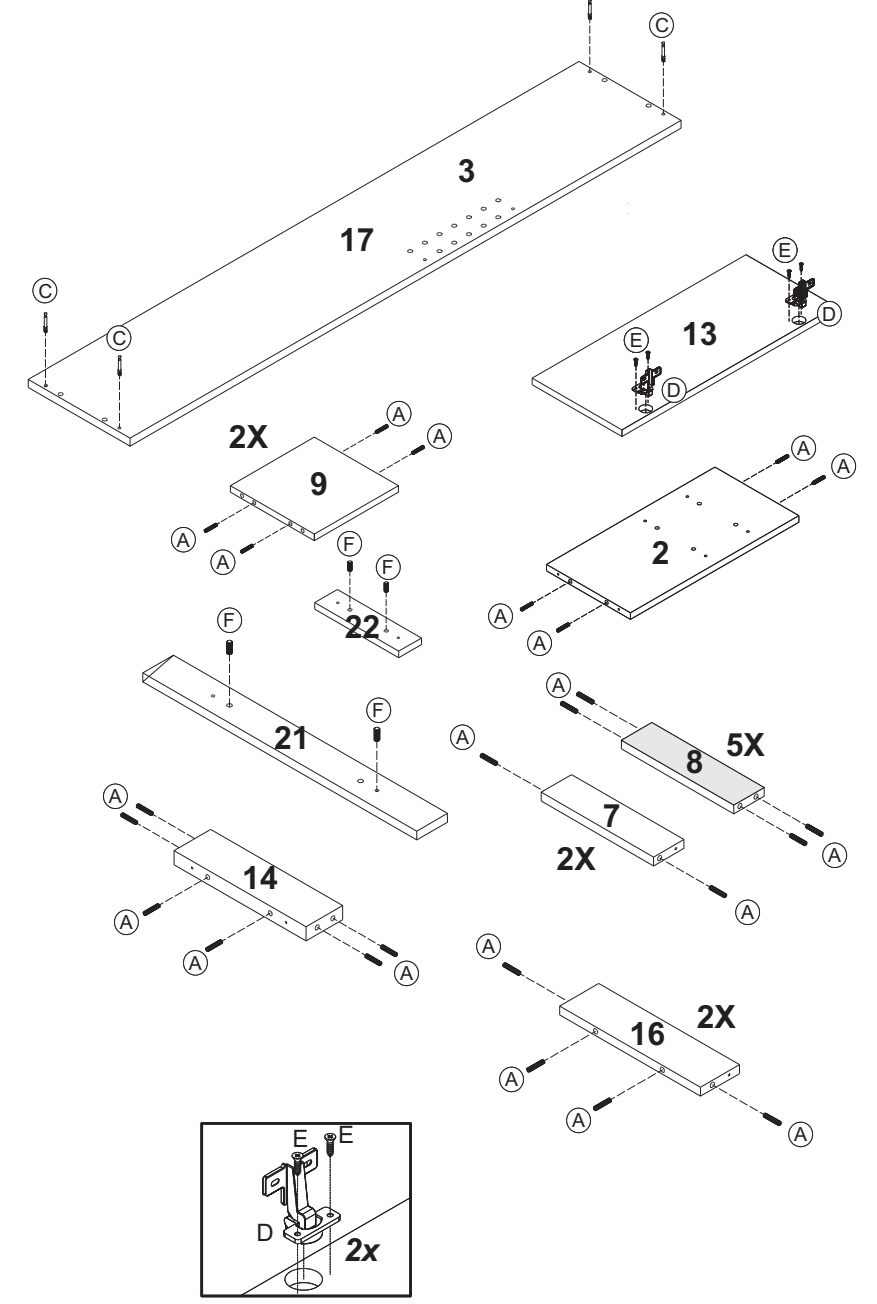

8

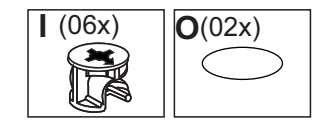
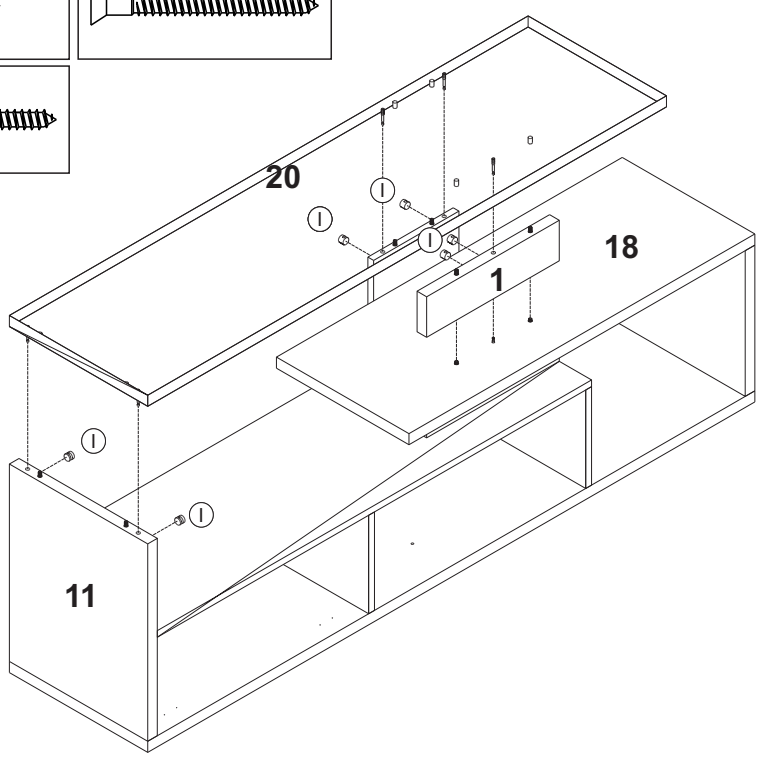

3

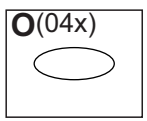
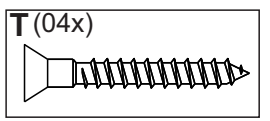
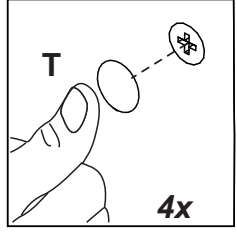
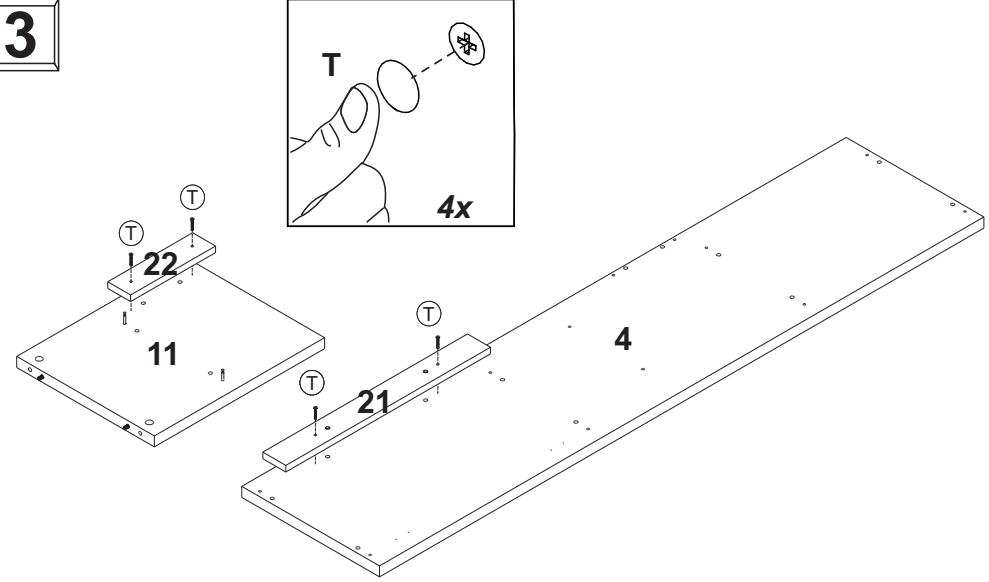

4

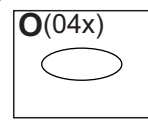
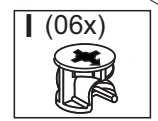
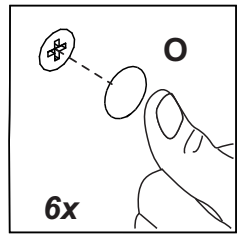
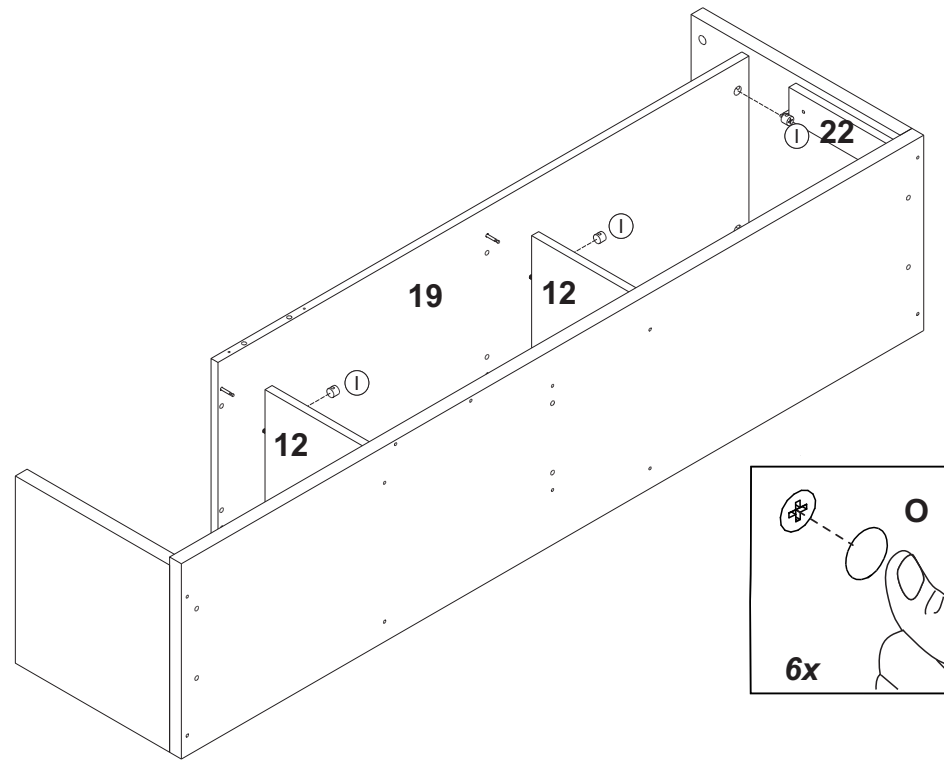
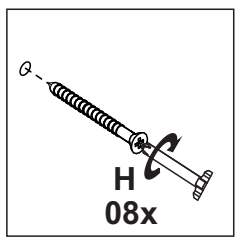
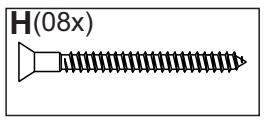
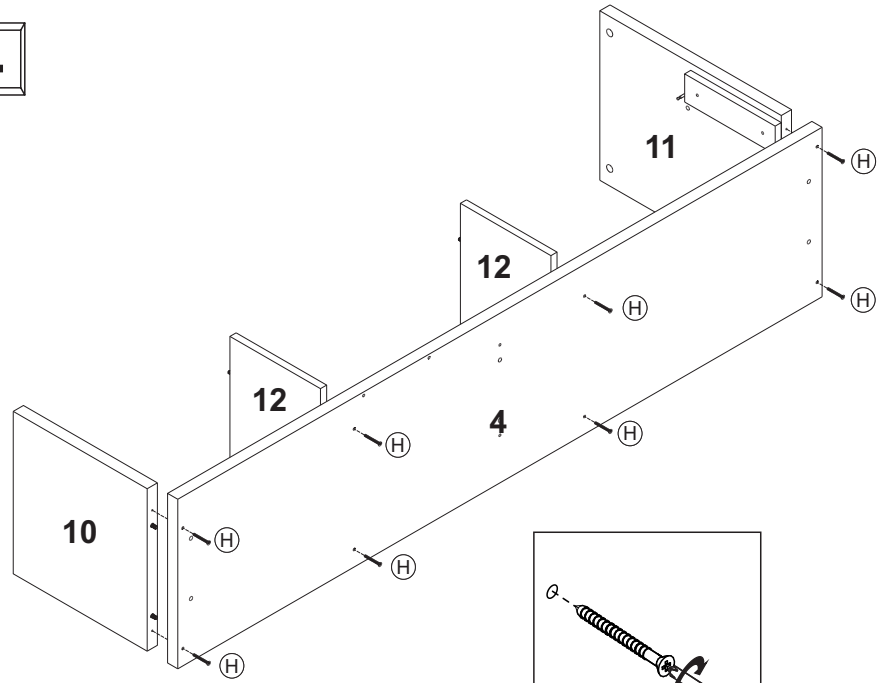

6

