

Doripel

móveis

MANUAL DE MONTAGEM
ASSEMBLE INSTRUCTONS
INSTRUCCIONES DE ARMADO

SP 5000
SAPATEIRA

Accesse a Instrução de montagem completa pelo QRCode.

Access the complete assembly instructions via QRCode.

Accede las instrucciones de montaje completas mediante QRCode.

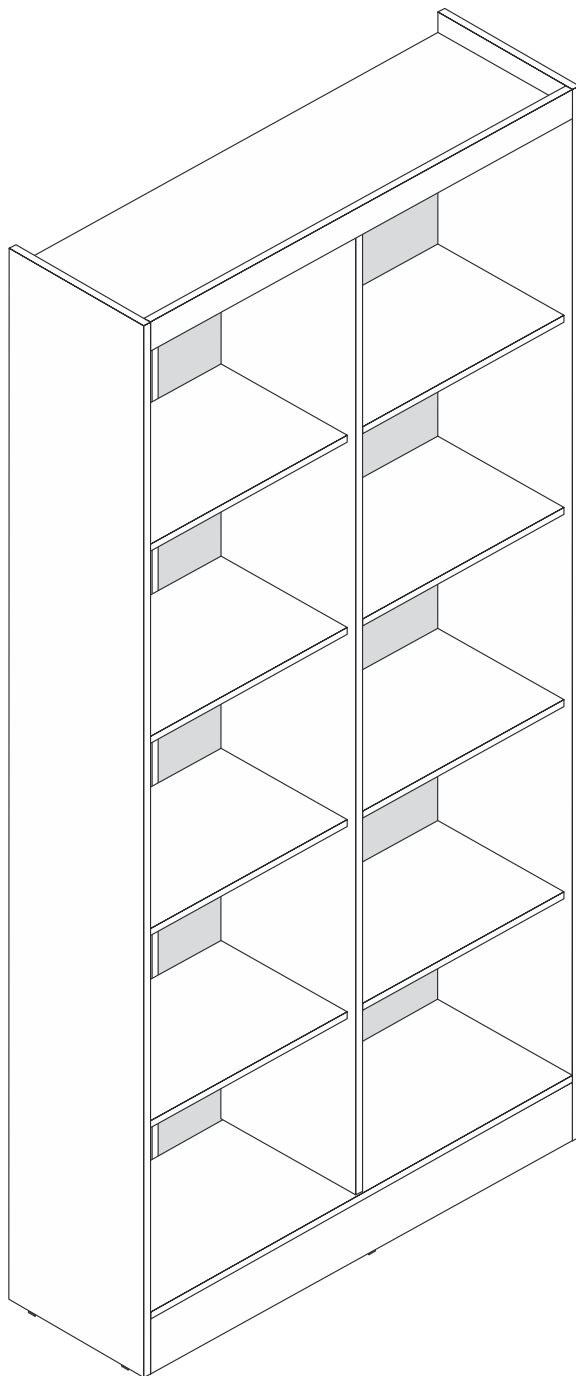
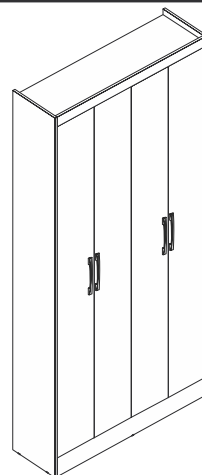

INSTRUÇÕES DE MONTAGEM DO ROUPEIRO

- 1- Começa preparando o espaço onde vai ser montado o roupeiro. Forre o chão para que não arranhe o móvel.
 - 2- Ter as ferramentas necessárias como: parafusadeira, chave de fenda, etc.
 - 3- Abrir as caixas e conferir as peças conforme está no manual.
 - 4- Fazer a separação das peças como indicado na imagem.
 - 5- Começa pela base pelas partes menores seguindo as etapas descritas no manual.
 - 6- Montar o roupeiro deitado com a frente para baixo para facilitar o trabalho.
 - 7- As portas e gavetas serão instaladas por último.
 - 8- E por fim verifique se está tudo certo alinhado e fixado corretamente.
- Lembrando que o esquema de montagem varia entre os modelos de roupeiros.
 - É aconselhável pedir ajuda a outra pessoa para te auxiliar na hora de erguer o móvel.

WARDROBE ASSEMBLY INSTRUCTIONS

- 1- Start by preparing the space where the wardrobe will be assembled. Cover the floor so that it does not scratch the furniture.
 - 2- Have the necessary tools such as: screwdriver, screwdriver, etc.
 - 3- Open the boxes and check the parts as shown in the manual.
 - 4- Separate the parts as shown in the image.
 - 5- Start at the base with the smallest parts following the steps described in the manual.
 - 6- Assemble the wardrobe lying face down to make the work easier.
 - 7- The doors and drawers will be installed last.
 - 8- And finally check that everything is aligned and correctly fixed.
- Remember that the assembly scheme varies between wardrobe models.
 - It is advisable to ask another person to help you when lifting the furniture.





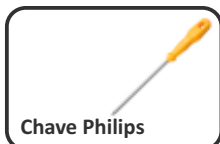

INSTRUCCIONES DE MONTAJE DEL ARMARIO

- 1- Prepare el espacio donde se montará el armario. Cubra el suelo para que no raye el mueble.
 - 2- Disponga de las herramientas necesarias, como destornillador, destornillador, etc.
 - 3- Abra las cajas y revise las piezas como se indica en el manual.
 - 4- Separe las piezas como se muestra en la imagen.
 - 5- Comience por la base con las piezas más pequeñas siguiendo los pasos descritos en el manual.
 - 6- Monte el armario boca abajo para facilitar el trabajo.
 - 7- Las puertas y los cajones se instalarán en último lugar.
 - 8- Por último, compruebe que todo esté alineado y correctamente fijado.
- Recuerde que el esquema de montaje varía según el modelo de armario.
 - Se recomienda pedir ayuda a otra persona para levantar el mueble.

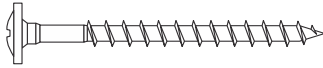
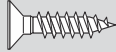
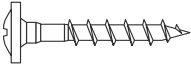
MATERIAL PARA MONTAGEM | ASSEMBLY MATERIAL | MATERIAL PARA ARMADO

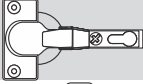

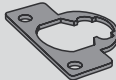
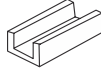
FERRAGEM | HARDWARE | HERRAJES

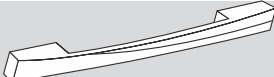
A	PARAFUSO FLANGEADO 3,5x40 FLANGE SCREW 3,5x40 TORNILLO FLANGEADO 3,5x40		18
B	PARAFUSO 3,5x12 C/C SCREW 3,5x12 TORNILLO 3,5x12		62
C	PARAFUSO FLANGEADO 3,5x25 FLANGE SCREW 3,5x25 TORNILLO FLANGEADO 3,5x25		08
D	CANTONEIRA 18x18 15x15 CORNER ESQUINA 15x15		07
E	PREGO 10x10 C/C NAIL 10x10 CLAVO 10x10		50
F	DOBRADIÇA HINGE BISAGRA		12
G	CALÇO DOBRADIÇA HINGE MOUNTING PLATE BASE DE BISAGRA		12
H	ARRUELA DOBRADIÇA HINGE WASHER ARANDELA DE BISAGRA		12
I	SAPATA SHOE ZAPATA		06
J	SUPORTE PRATELEIRA SHELF SUPPORT APOYO ESTANTE		32
K	PERFIL PROFILE PERFIL		02
L	PUXADOR HANDLE TIRADOR		04



UTILIZE A RÉGUA PARA A MEDIÇÃO DOS PARAFUSOS | USE THE RULER TO MEASURE THE SCREWS | USA LA REGLA PARA MEDIR LOS TORNILLOS



CÓDIGO CODE CODIGO	DESCRIÇÃO DESCRIPTION DESCRIPCIÓN	QTD. QUANTITY CANTIDAD	DIMENSÕES DIMENSIONS DIMENSIONES		
			COMP. LENGTH LONGITUD	LARG. WIDTH ANCHO	CHAPA PLATE LÁMINA
722	PORTA DOOR / PUERTA	04	1,545	0,224	12mm
641	RODAPÉ FRONTAL FRONT SKIRT / RODAPIÉ FRONTAL	01	0,892	0,158	12mm
646	LATERAL DIREITA RIGHT SIDE / LATERAL DERECHA	01	1,755	0,297	12mm
647	LATERAL ESQUERDA LEFT SIDE / LATERAL IZQUIERDA	01	1,755	0,297	12mm
648	TAMPO INFERIOR BOTTOM PANEL / TAPA INFERIOR	01	0,892	0,297	9mm
537	PRATELEIRA SHELF / ESTANTE	08	0,440	0,268	9mm
649	DIVISÓRIA DIVIDER / DIVISIÓN	01	1,534	0,297	12mm
650	COSTAS BACK PANEL / PARTE TRASERA	03	1,570	0,300	3mm
123	RODAFORRO BOTTOM TRIM / ZÓCALO	01	0,892	0,045	12mm
1505	TAMPO SUPERIOR TOP PANEL / TAPA SUPERIOR	01	0,892	0,297	9mm
1791	RODAPÉ TRASEIRO REAR SKIRT / RODAPIÉ TRASERO	01	0,892	0,158	12mm

Preparando a Lateral Esquerda.

Preparing Left Side.

Preparante Lateral Izquierda.

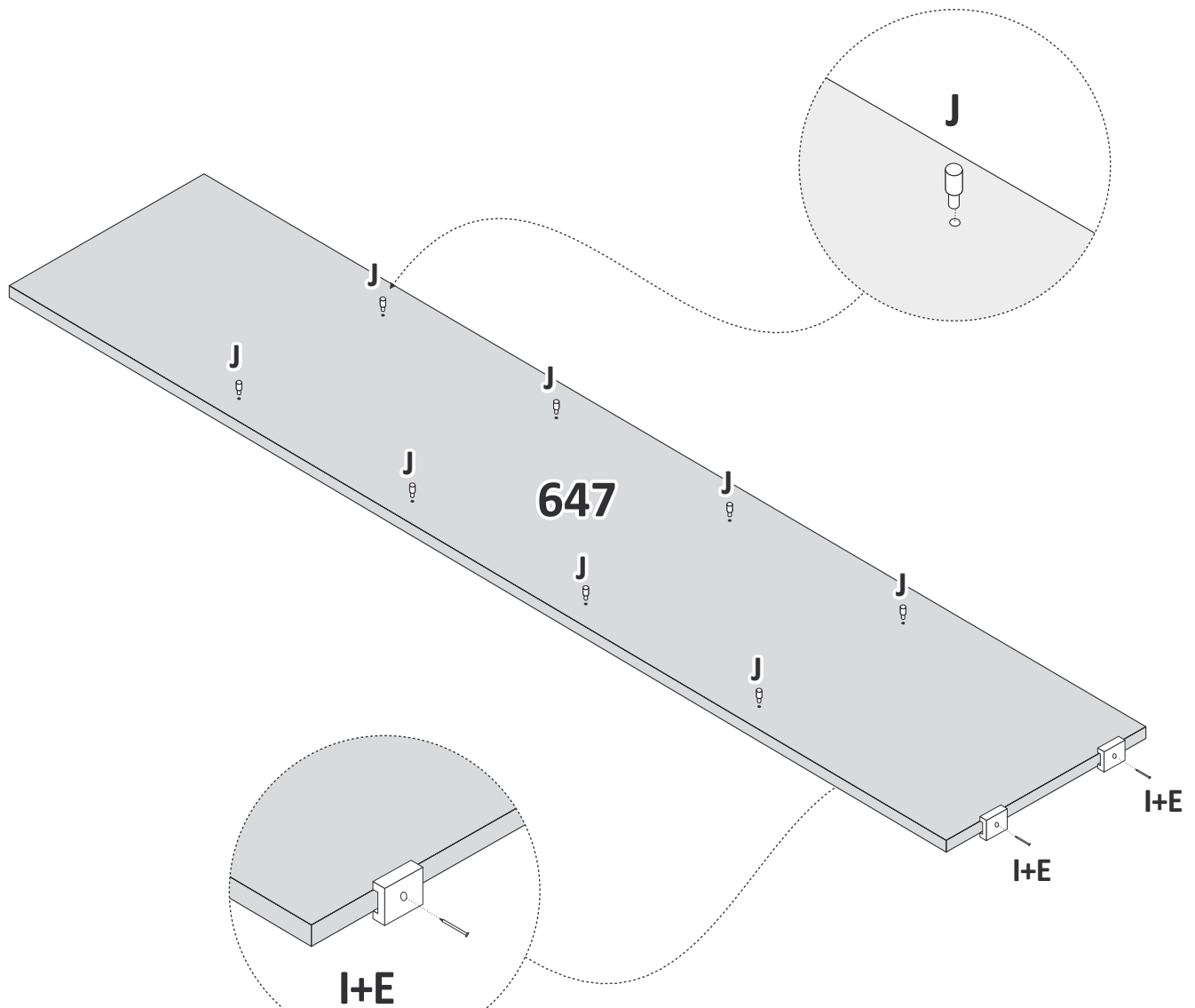

COLOCAÇÃO DAS SAPATAS.

putting on the shoes.
poniéndose los zapatos.

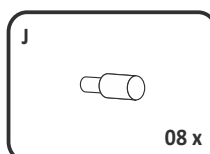
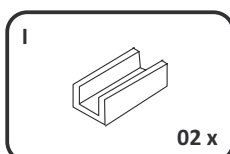
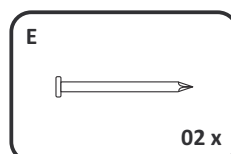

Preparando a Lateral Direita.

Preparing Right Side.

Preparante Lateral Derecha.

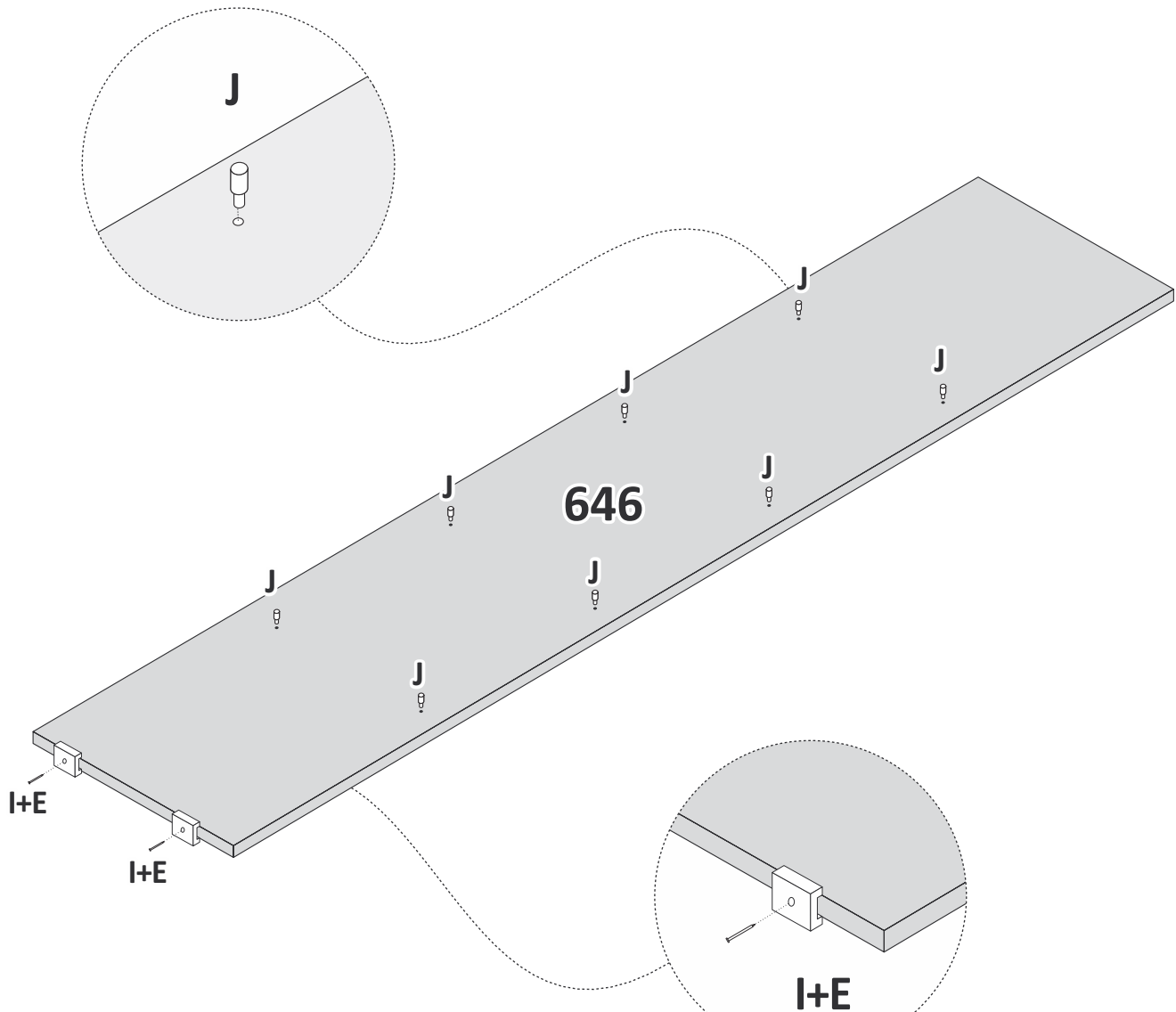

COLOCAÇÃO DAS SAPATAS.

putting on the shoes.

poniéndose los zapatos.

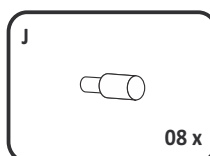
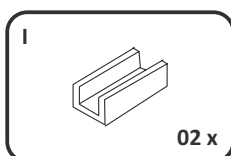
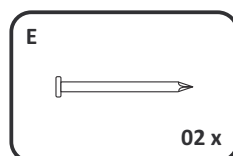

Preparando a Divisão.

Preparing Divider.
Preparante División.

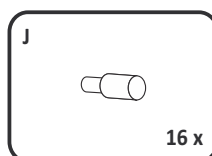
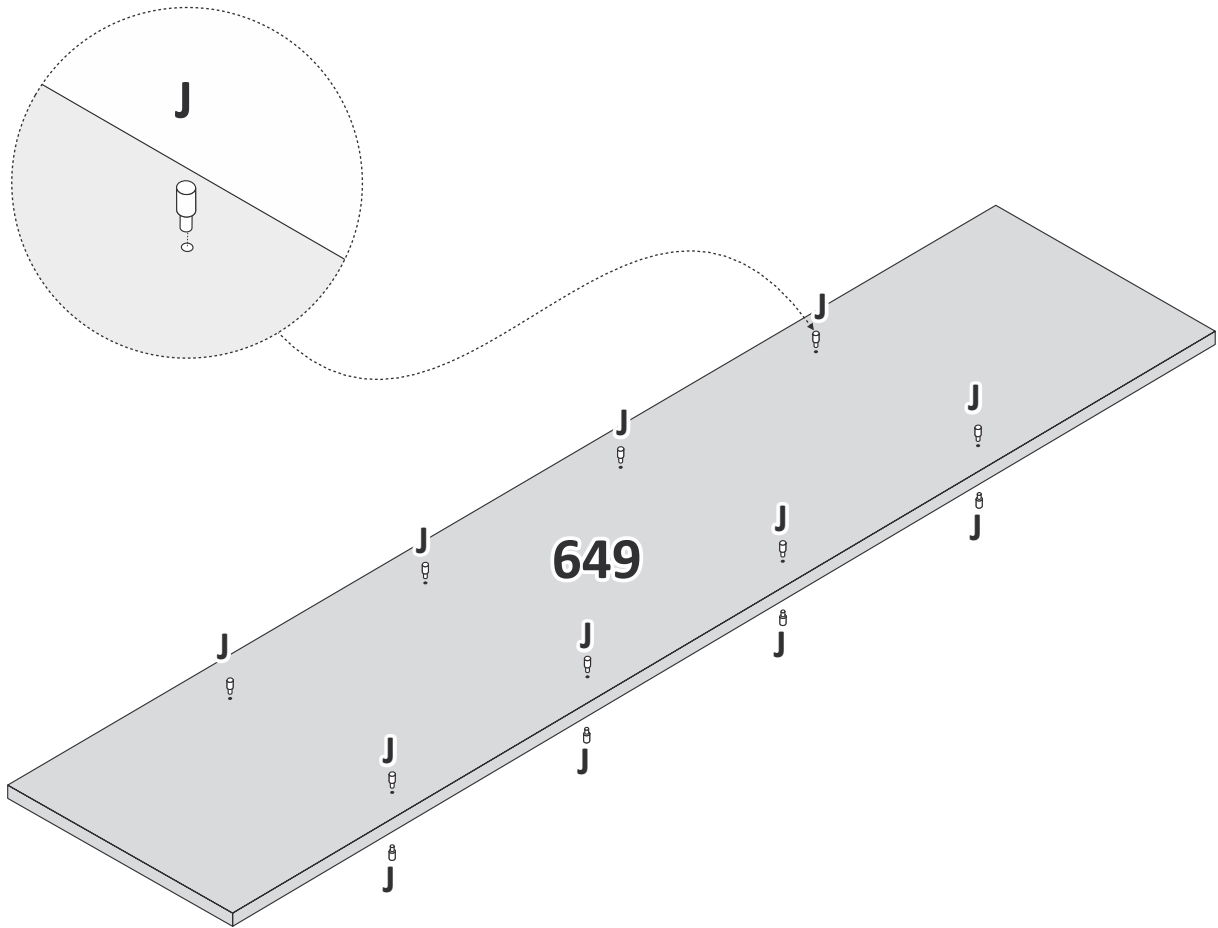

Montagem Tampo Superior e Inferior na Divisória.

Assembly of the Top and Bottom Panels on the Divider.

Montaje del Tampo Superior e Inferior en la División.

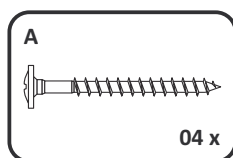
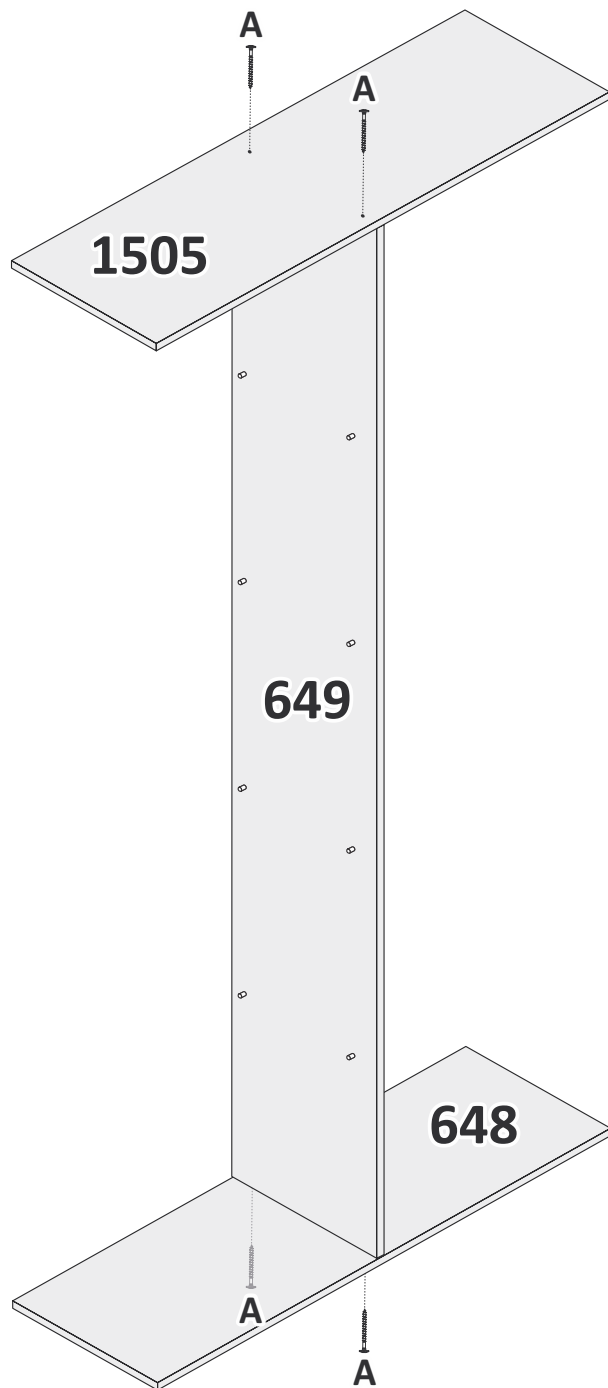

Montagem Laterais no Tampo Superior.

Assembly Sides on the Top Panel.

Montaje Laterales en la Tampo Superior.

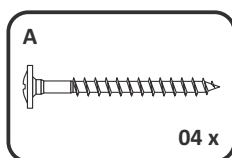
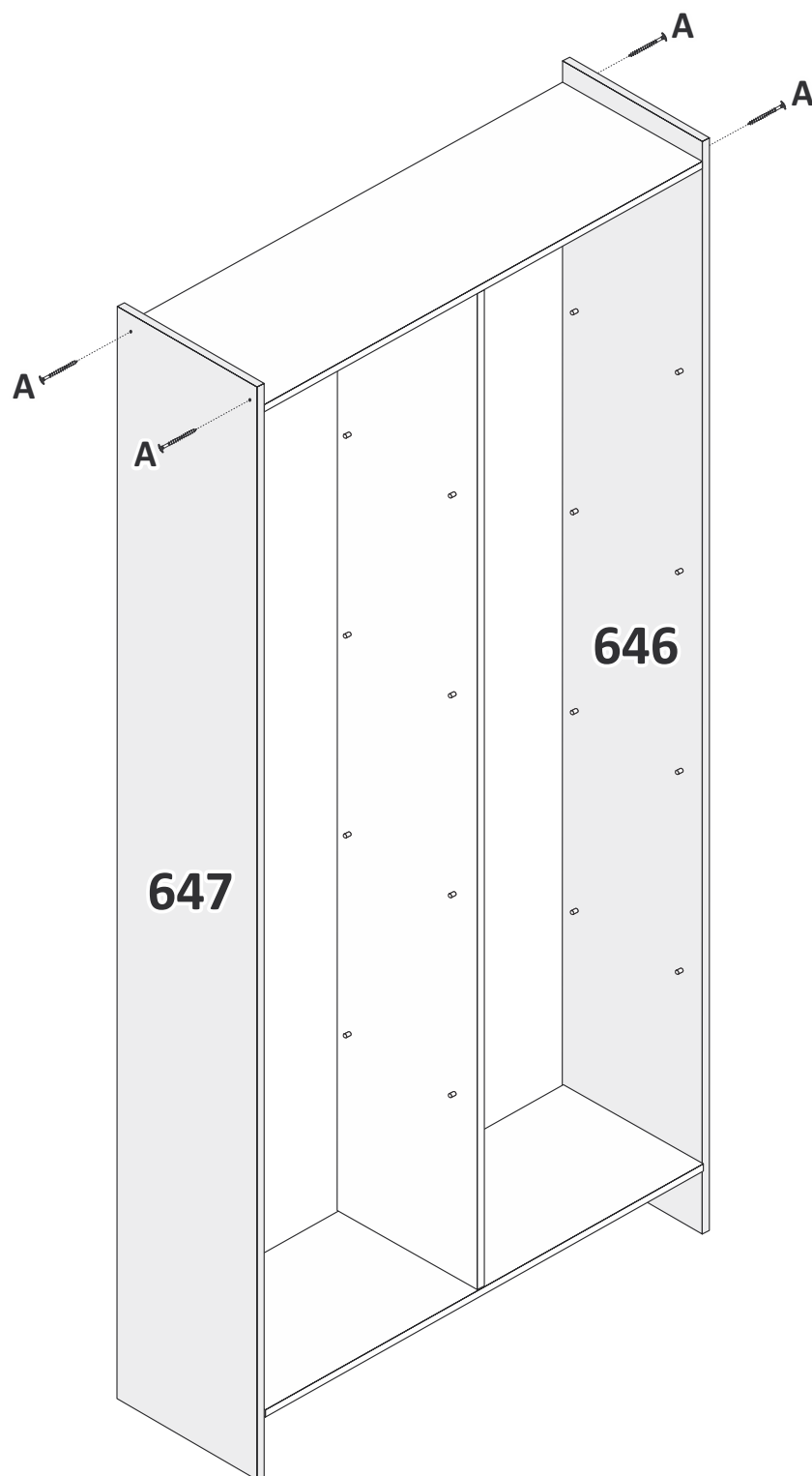

Preparando Rodapé.

Preparing Baseboard.
preparando Zócalo.

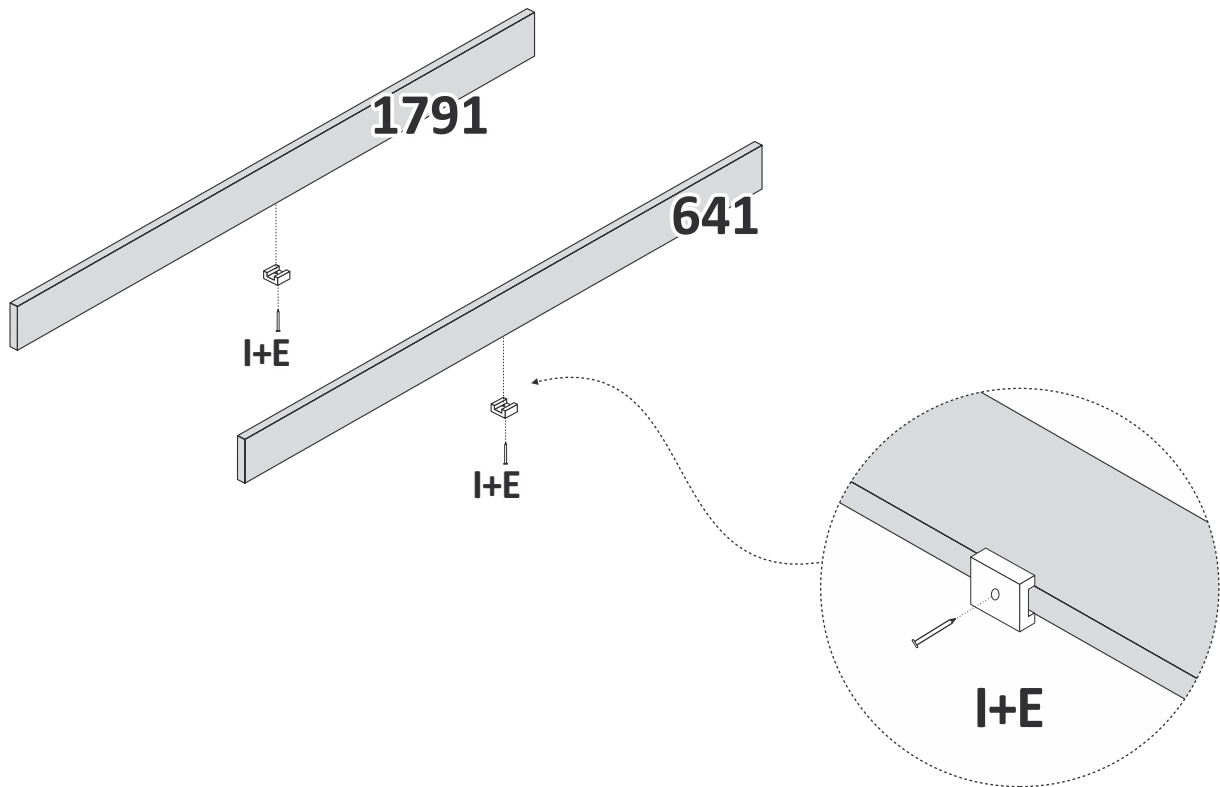

COLOCAÇÃO DAS SAPATAS.

putting on the shoes.
poniéndose los zapatos.

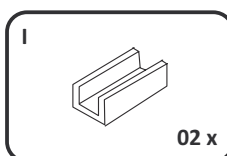
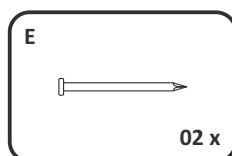

Montar Rodapé.

Assembly Baseboard.

Montaje Zócalo.

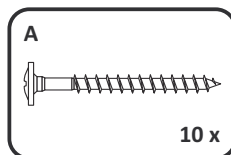
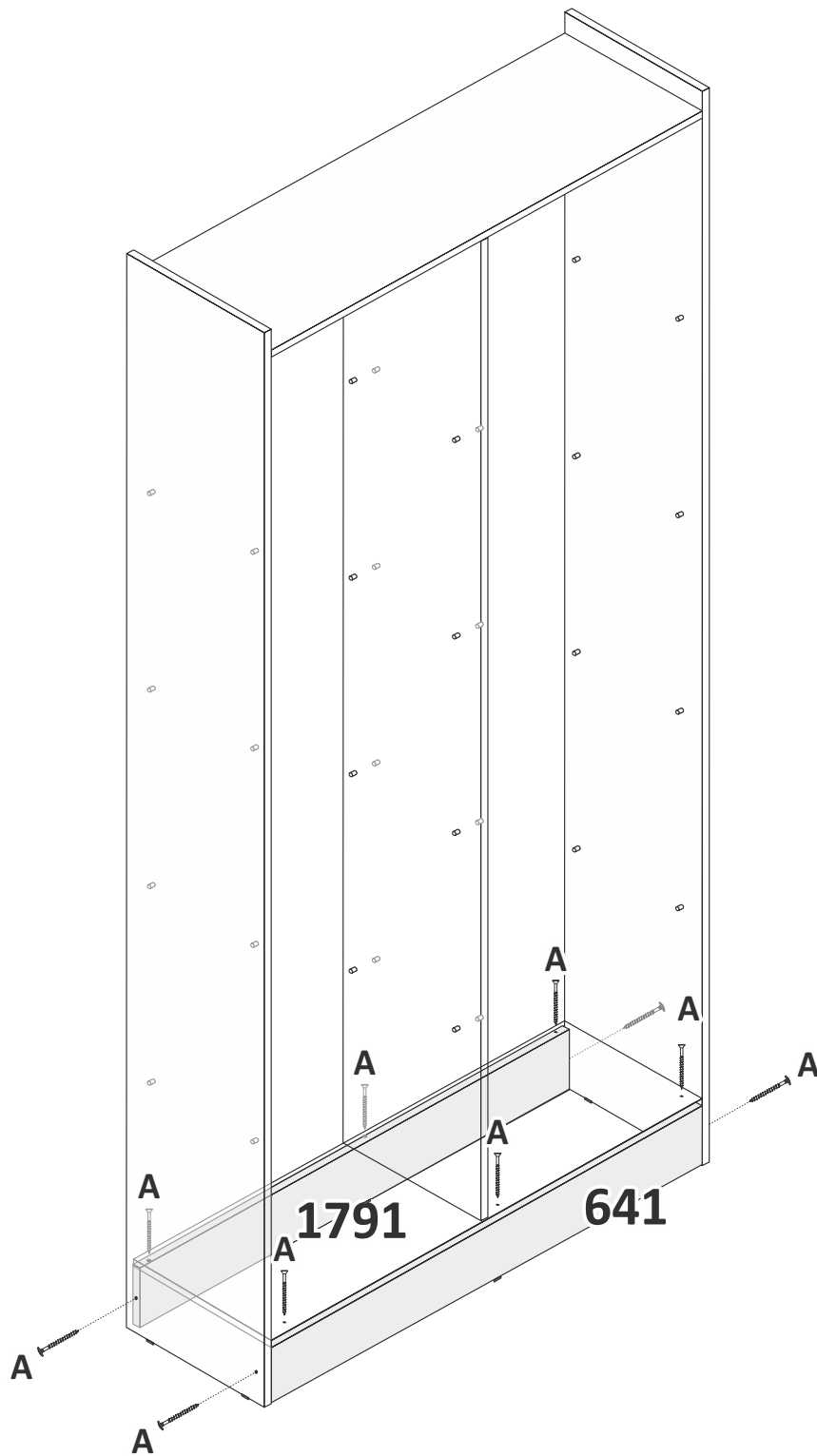

Montagem Rodaforro.

Assembly Rodaforro.
Montaje de Rodaforro.

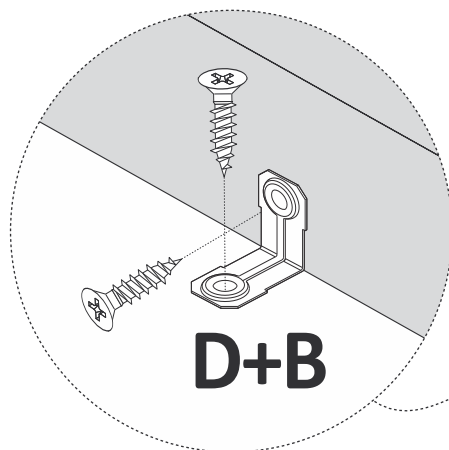

D+B

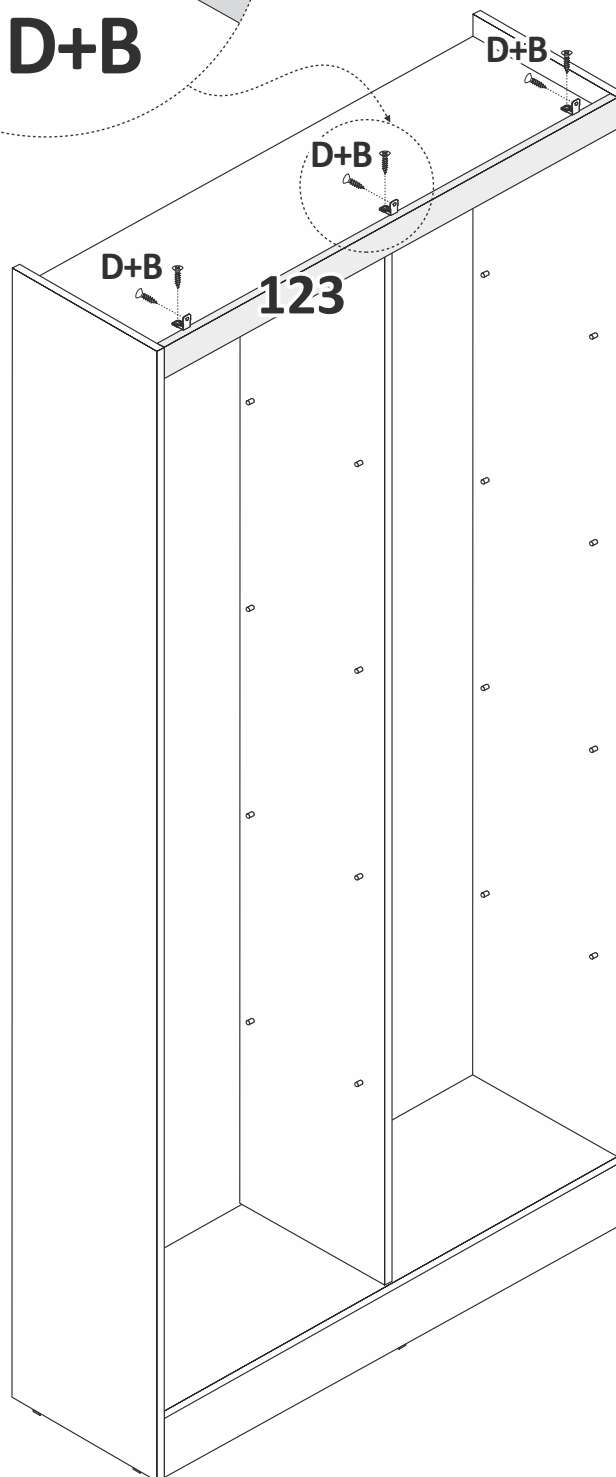

123

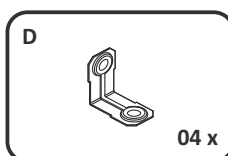
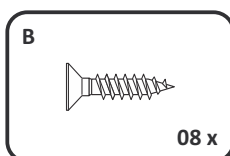

Montagem das Costas.

Back Assembly.
Montaje Trasero.

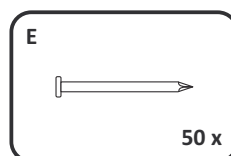
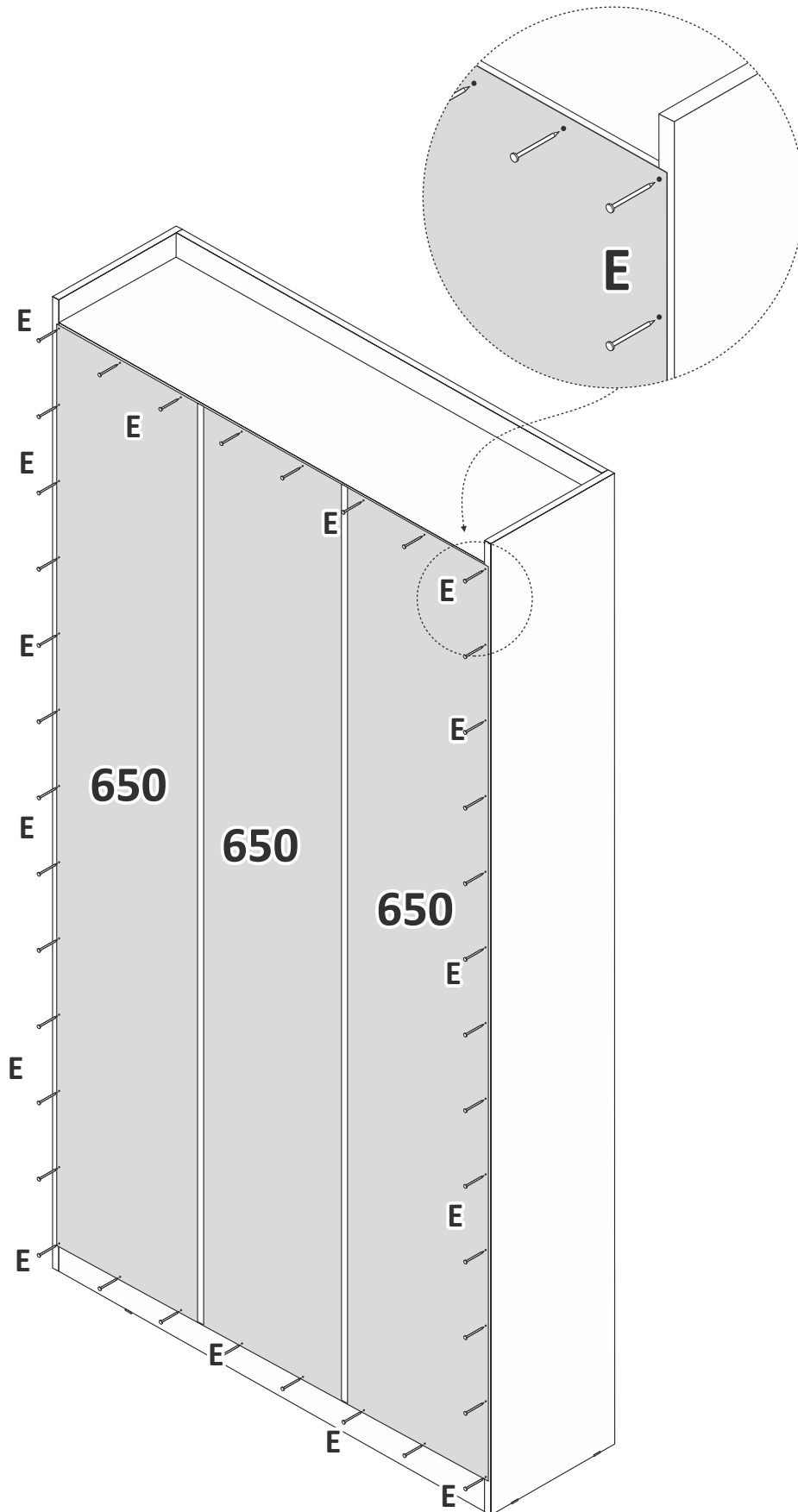

Montagem das Prateleiras.

Assembly Shelves.
Montaje de Estantes.

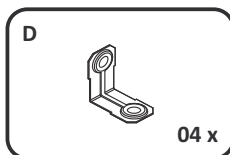
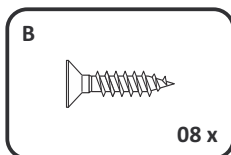
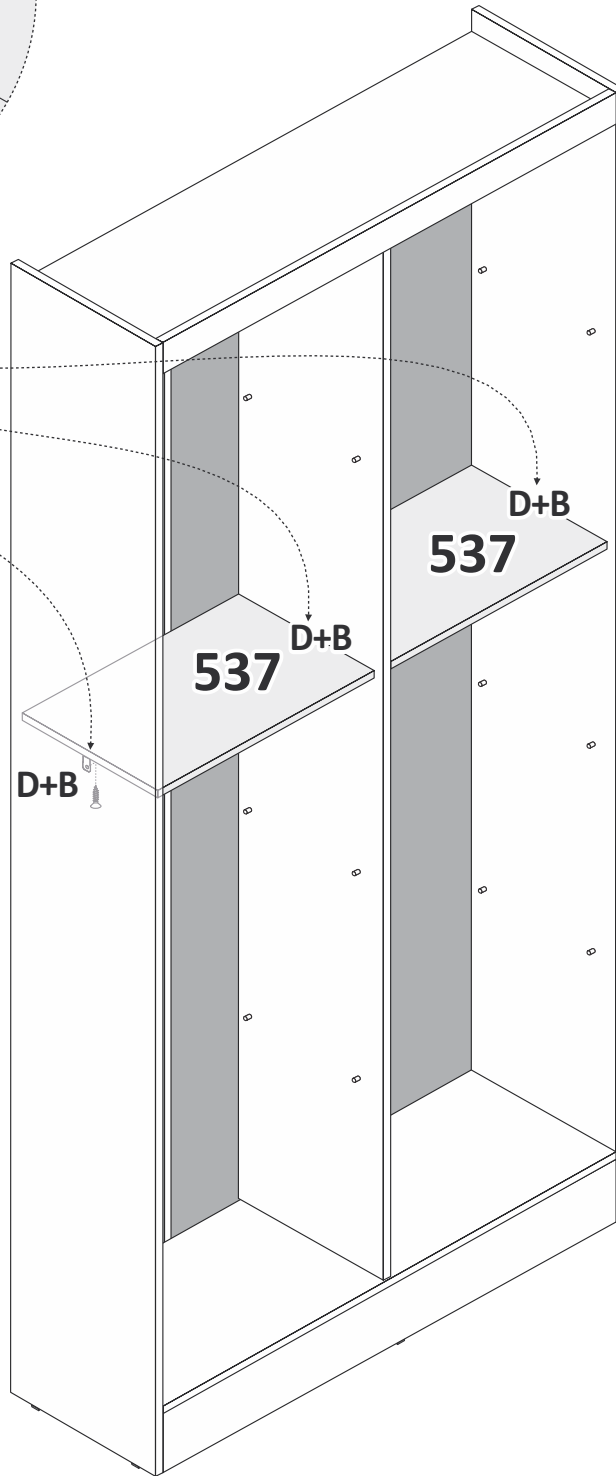
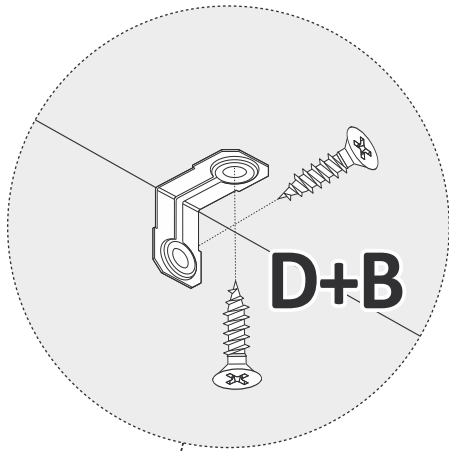

Montagem das Prateleiras.

Assembly Shelves.
Montaje de Estantes.

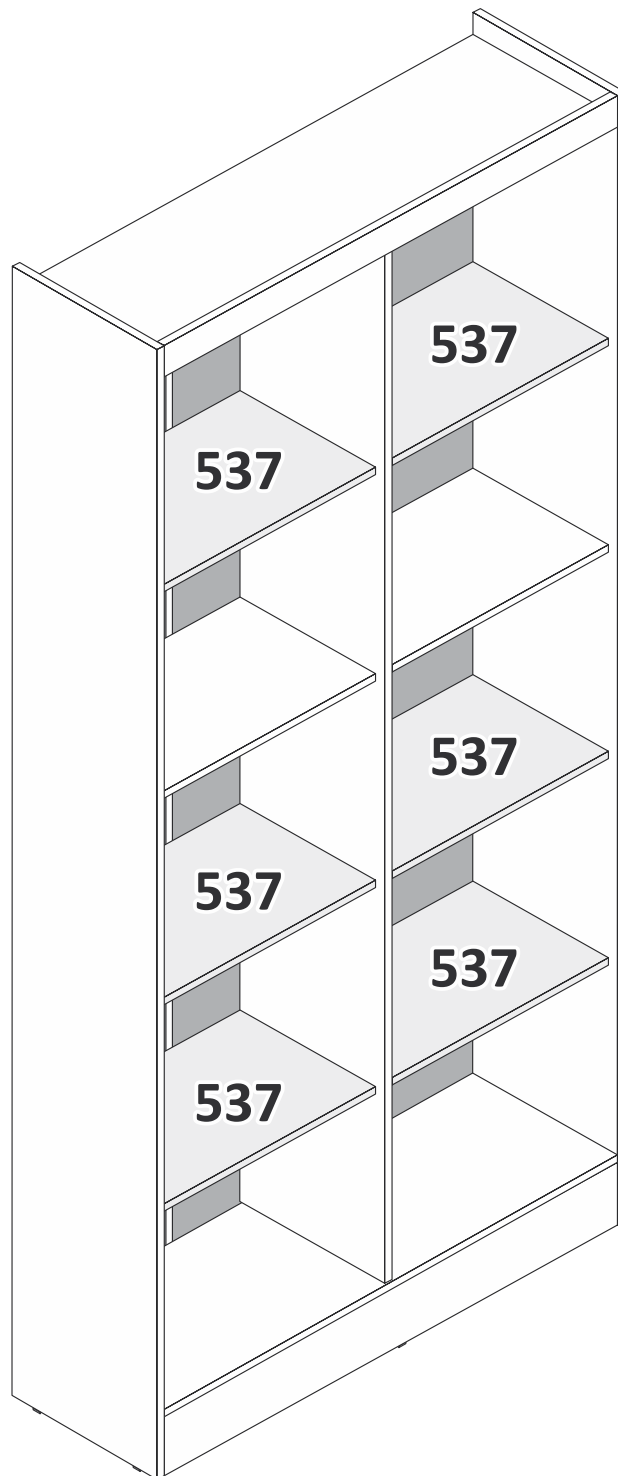

Peso suportado em cada parte.

Weight supported on each part.

Peso soportado en cada parte.

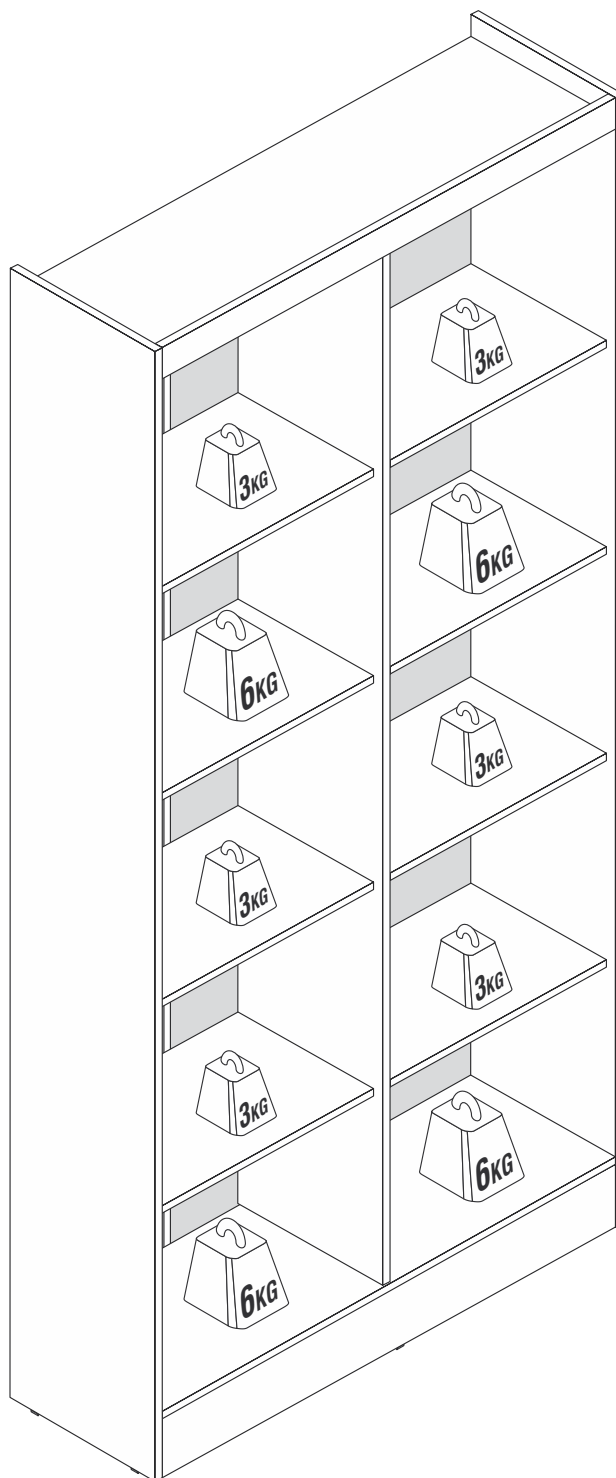

Medidas espaços internos.

Internal spaces measurements.

Medidas del espacios interiores.

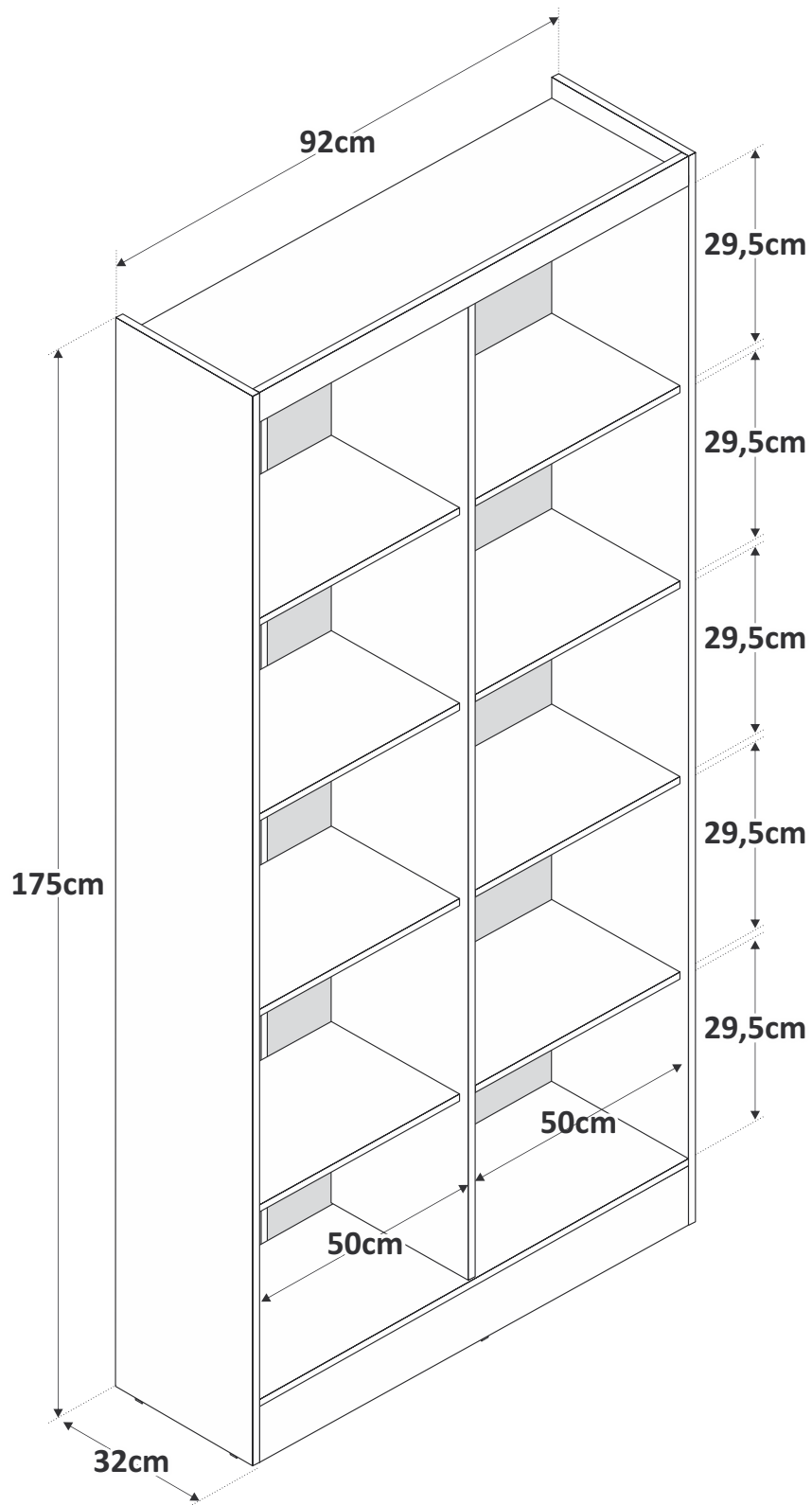

Montagem Porta Esquerda Grande.

Big Left Side Door Assembly.

Montaje de la Puerta Lateral Izquierda Grande.

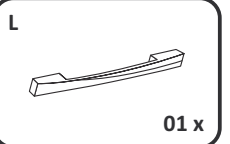
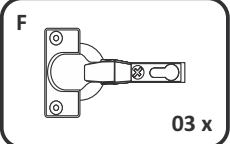
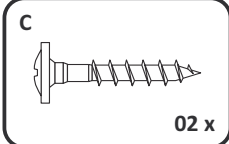
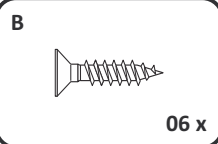
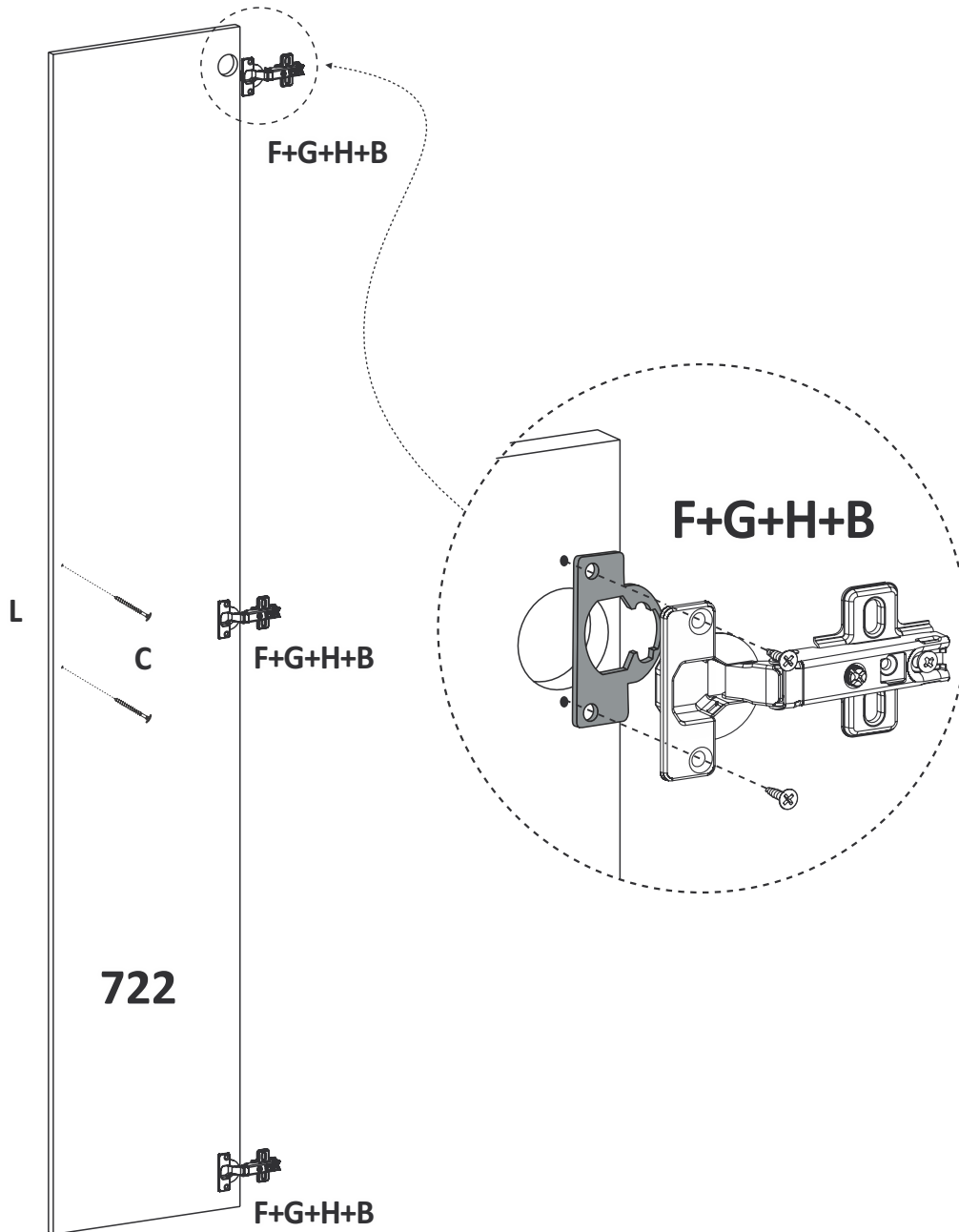

Montagem Porta Direita Grande.

Big Right Side Door Assembly.

Montaje de la Puerta Lateral Derecha Grande.

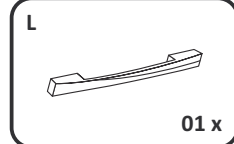
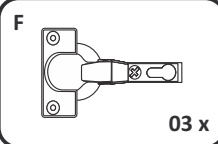
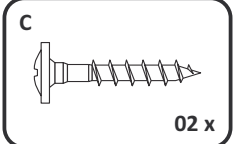
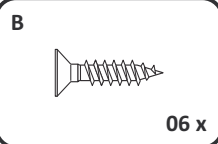
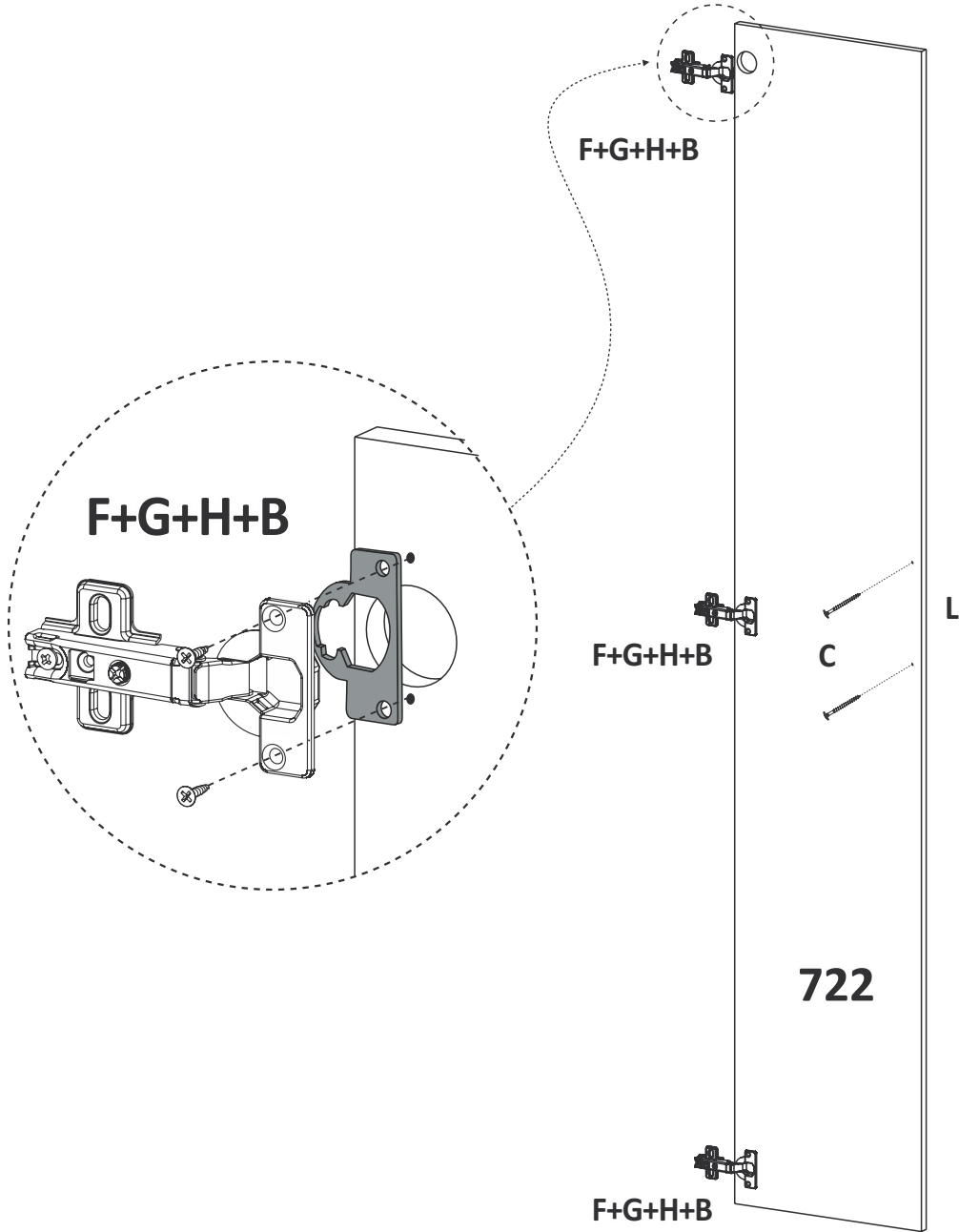

Coloção das Portas.

Door Placement.

Colocación de Puertas.

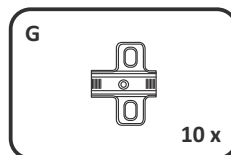
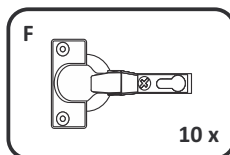
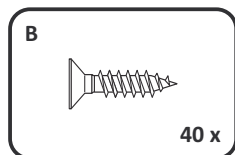
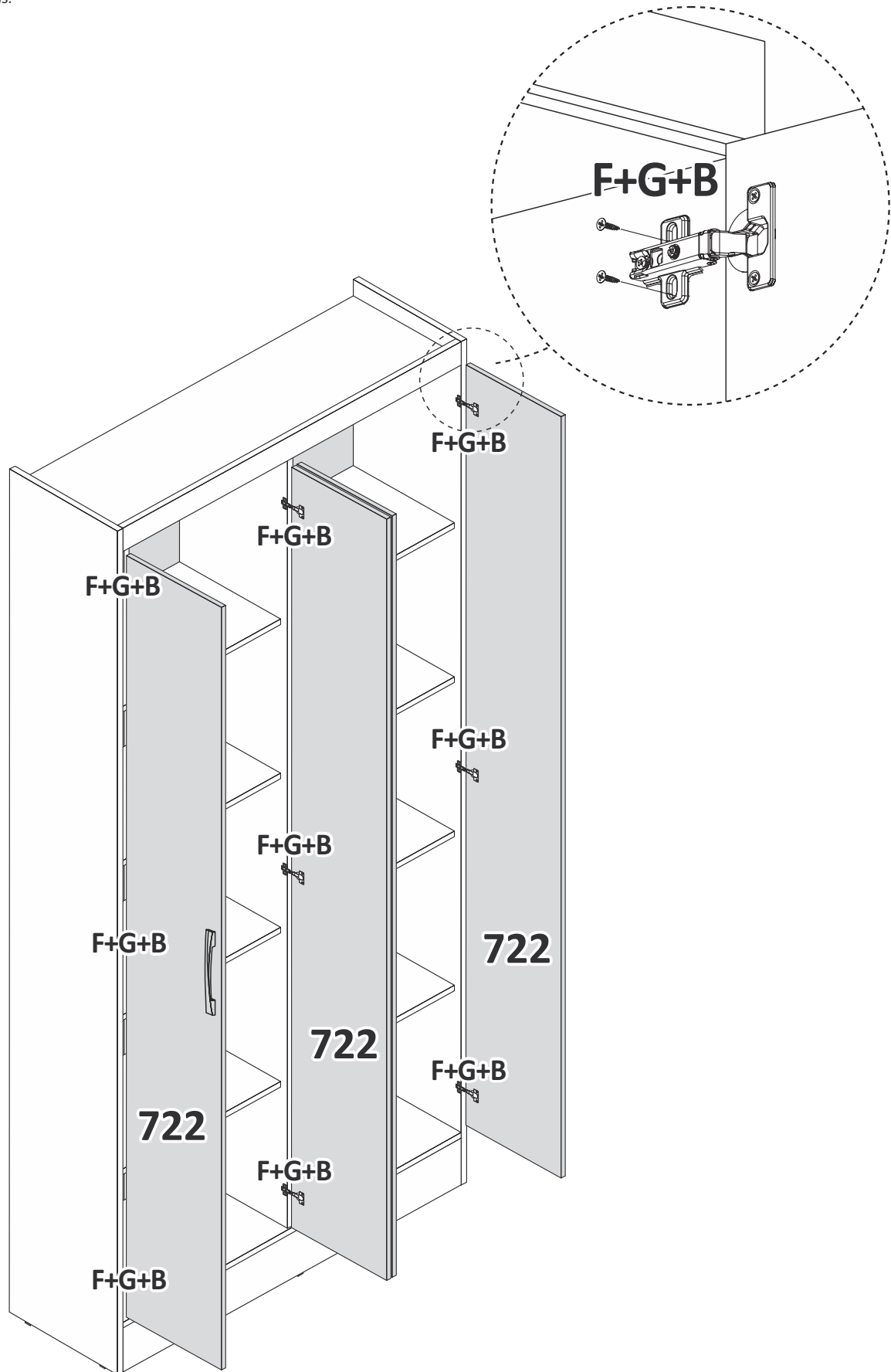

Produto montado.

Asembled product.
Producto ensamblado.

☎ 98887667

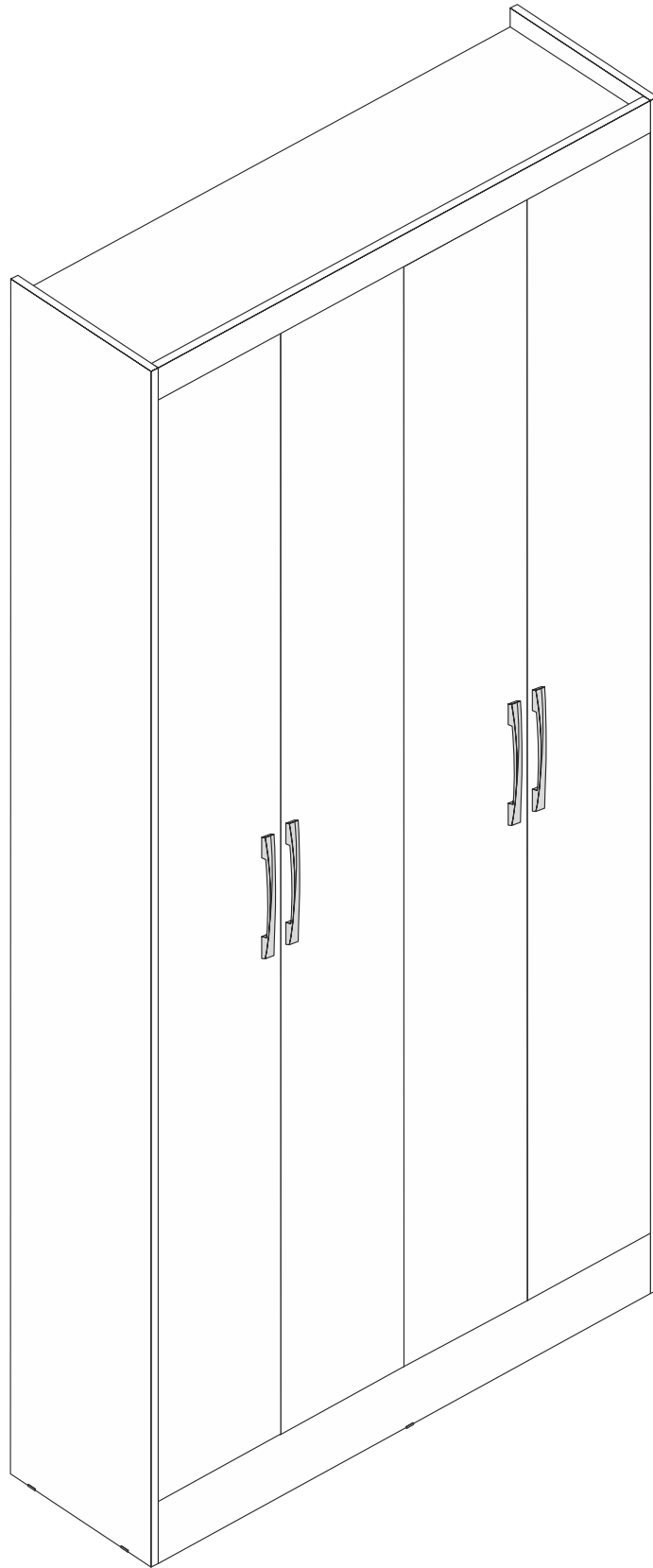



Doripel
móveis

Moveis.Doripel 

DoripelMoveis 

54 3358.6500 

Av. Julio Vanzin, 1600 - Área Industrial Lagoa Vermelha - RS - Brasil 

comercial@doripel.com.br | assistencia@doripel.com.br 

doripel.com.br 