

Doripel

móveis

MANUAL DE MONTAGEM
ASSEMBLE INSTRUCTONS
INSTRUCCIONES DE ARMADO

RP 68600
RP 40650
Roupeiro 06 Pts

Accesse a Instrução de montagem completa pelo QRCode.

Access the complete assembly instructions via QRCode.

Accede las instrucciones de montaje completas mediante QRCode.



RP 68600

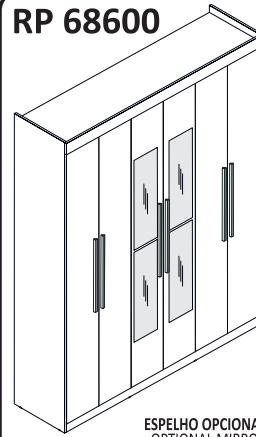

ESPELHO OPCIONAL
OPTIONAL MIRROR
ESPEJO OPCIONAL

RP 40650

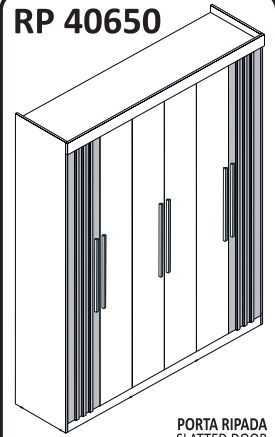

PORTA RIPADA
SLATTED DOOR
PUERTA RANURADA

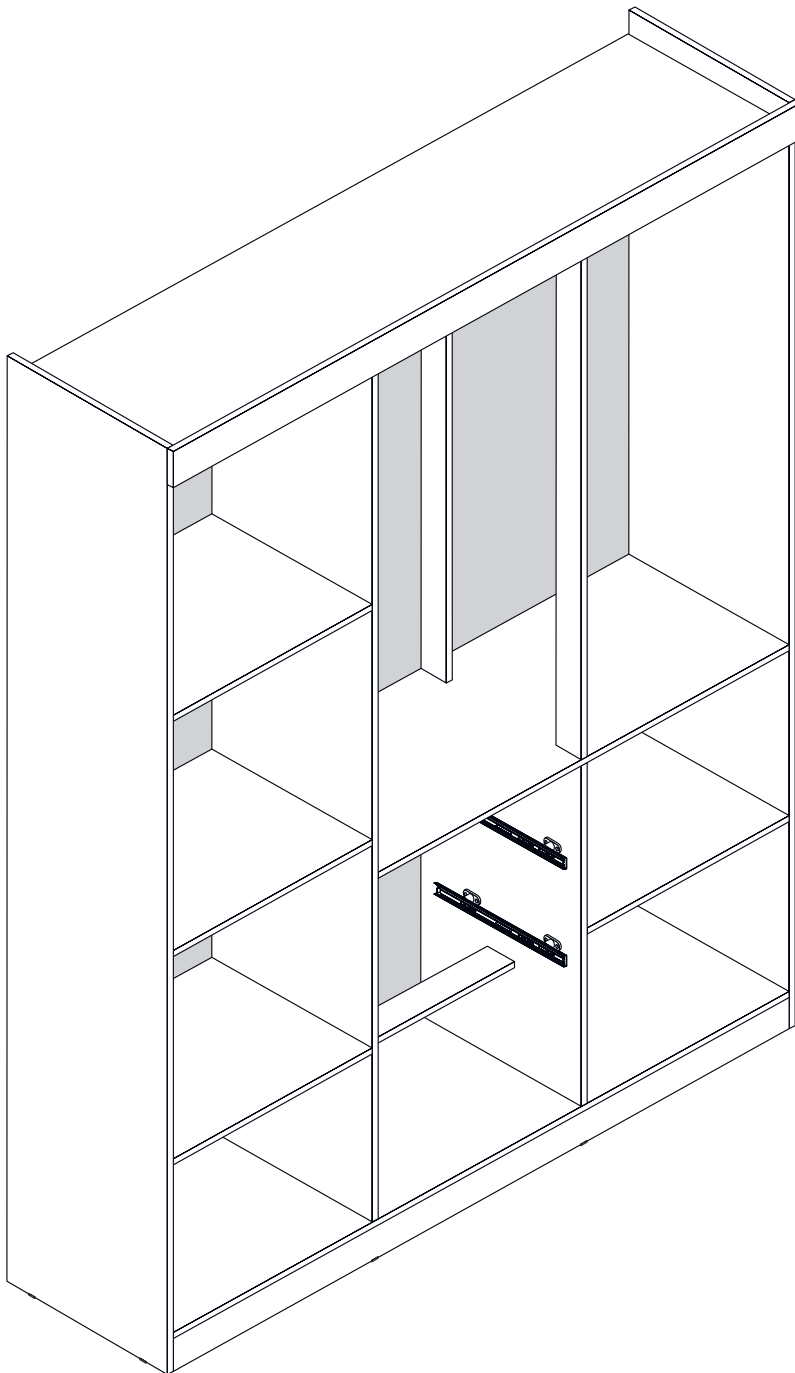

INSTRUÇÕES DE MONTAGEM DO ROUPEIRO

- 1- Começa preparando o espaço onde vai ser montado o roupeiro. Forre o chão para que não arranhe o móvel.
 - 2- Ter as ferramentas necessárias como: parafusadeira, chave de fenda, etc.
 - 3- Abrir as caixas e conferir as peças conforme está no manual.
 - 4- Fazer a separação das peças como indicado na imagem.
 - 5- Começa pela base pelas partes menores seguindo as etapas descritas no manual.
 - 6- Montar o roupeiro deitado com a frente para baixo para facilitar o trabalho.
 - 7- As portas e gavetas serão instaladas por último.
 - 8- E por fim verifique se está tudo certo alinhado e fixado corretamente.
- Lembrando que o esquema de montagem varia entre os modelos de roupeiros.
 - É aconselhável pedir ajuda a outra pessoa para te auxiliar na hora de erguer o móvel.

WARDROBE ASSEMBLY INSTRUCTIONS

- 1- Start by preparing the space where the wardrobe will be assembled. Cover the floor so that it does not scratch the furniture.
 - 2- Have the necessary tools such as: screwdriver, screwdriver, etc.
 - 3- Open the boxes and check the parts as shown in the manual.
 - 4- Separate the parts as shown in the image.
 - 5- Start at the base with the smallest parts following the steps described in the manual.
 - 6- Assemble the wardrobe lying face down to make the work easier.
 - 7- The doors and drawers will be installed last.
 - 8- And finally check that everything is aligned and correctly fixed.
- Remember that the assembly scheme varies between wardrobe models.
 - It is advisable to ask another person to help you when lifting the furniture.







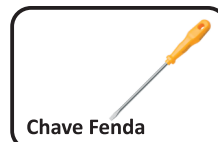
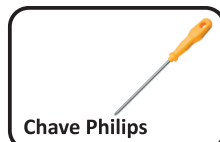



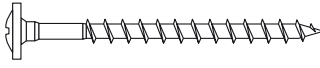
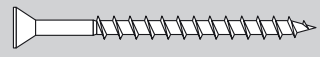
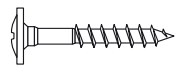
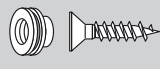
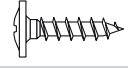
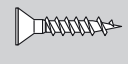

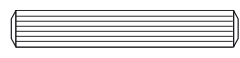

INSTRUCCIONES DE MONTAJE DEL ARMARIO

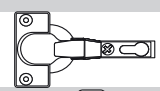
- 1- Prepare el espacio donde se montará el armario. Cubra el suelo para que no raye el mueble.
 - 2- Disponga de las herramientas necesarias, como destornillador, destornillador, etc.
 - 3- Abra las cajas y revise las piezas como se indica en el manual.
 - 4- Separe las piezas como se muestra en la imagen.
 - 5- Comience por la base con las piezas más pequeñas siguiendo los pasos descritos en el manual.
 - 6- Monte el armario boca abajo para facilitar el trabajo.
 - 7- Las puertas y los cajones se instalarán en último lugar.
 - 8- Por último, compruebe que todo esté alineado y correctamente fijado.
- Recuerde que el esquema de montaje varía según el modelo de armario.
 - Se recomienda pedir ayuda a otra persona para levantar el mueble.

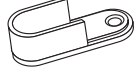
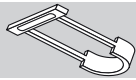
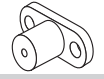
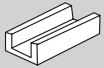
MATERIAL PARA MONTAGEM | ASSEMBLY MATERIAL | MATERIAL PARA ARMADO

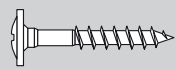
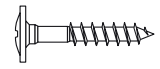

FERRAGEM | HARDWARE | HERRAJES

A	PARAFUSO FLANGEADO 3,5x40 FLANGE SCREW 3,5x40 TORNILLO FLANGEADO 3,5x40		39
B	PARAFUSO 3,5x40 SCREW 3,5x40 TORNILLO FLANGEADO 3,5x40		03
C	PARAFUSO FLANGEADO 3,5x25 FLANGE SCREW 3,5x25 TORNILLO FLANGEADO 3,5x25		12
D	KIT FIXADOR ESPELHO MIRROR FIXING KIT KIT FIJACIÓN ESPEJO		01
E	PARAFUSO FLANGEADO 3,5x12 FLANGE SCREW 3,5x12 TORNILLO FLANGEADO 3,5x12		120
F	PARAFUSO 3,5x16 SCREW 3,5x16 TORNILLO 3,5x16		08
G	FIXADOR FIXER FIJADOR		16
H	CANTONEIRA 18x18 15x15 CORNER ESQUINA 15x15		09
I	CAVILHA 6x30 6x30 PEGS TACOS 6x30		11
J	CAVILHA 6x50 6x50 PEGS TACOS 6x50		03
K	PREGO 10x10 C/C NAIL 10x10 CLAVO 10x10		110
L	PREGO 13x15 C/C NAIL 13x15 CLAVO 13x15		08
M	DOBRADIÇA HINGE BISAGRA		18
N	CALÇO DOBRADIÇA HINGE MOUNTING PLATE BASE DE BISAGRA		18
O	SUPORTE CABIDEIRO HANGER SUPPORT APOYO PERCHERO		02
P	SUPORTE CENTRAL CENTER SUPPORT APOYO CENTRAL		01
Q	DISTANCIADOR 32mm 32mm DISTANCER DISTANCIADOR 32mm		08
R	SAPATA SHOE ZAPATA		08
S	SUPORTE PRATELEIRA SHELF SUPPORT SOPORTE ESTANTE		12
T	COLA GLUES PEGAMENTO		01
U	CABIDEIRO HANGER PERCHERO		01
V	PUXADOR HANDLE TIRADOR		06
W	CORREDIÇA SLIDER CORREDIZA		02
X	PARAFUSO 3,5x25 FLANGEADO (RIPADO) 3,5x25 FLANGE SCREW (SLATTED) TORNILLO 3,5x25 FLANGEADO (RANURADO)		18
Z	PARAFUSO FLANGEADO 3,5x20 FLANGE SCREW 3,5x20 TORNILLO FLANGEADO 3,5x20		02



UTILIZE A RÉGUA PARA A MEDIÇÃO DOS PARAFUSOS | USE THE RULER TO MEASURE THE SCREWS | USA LA REGLA PARA MEDIR LOS TORNILLOS

LISTA DE PEÇAS | PARTS LIST | LISTA DE PIEZAS

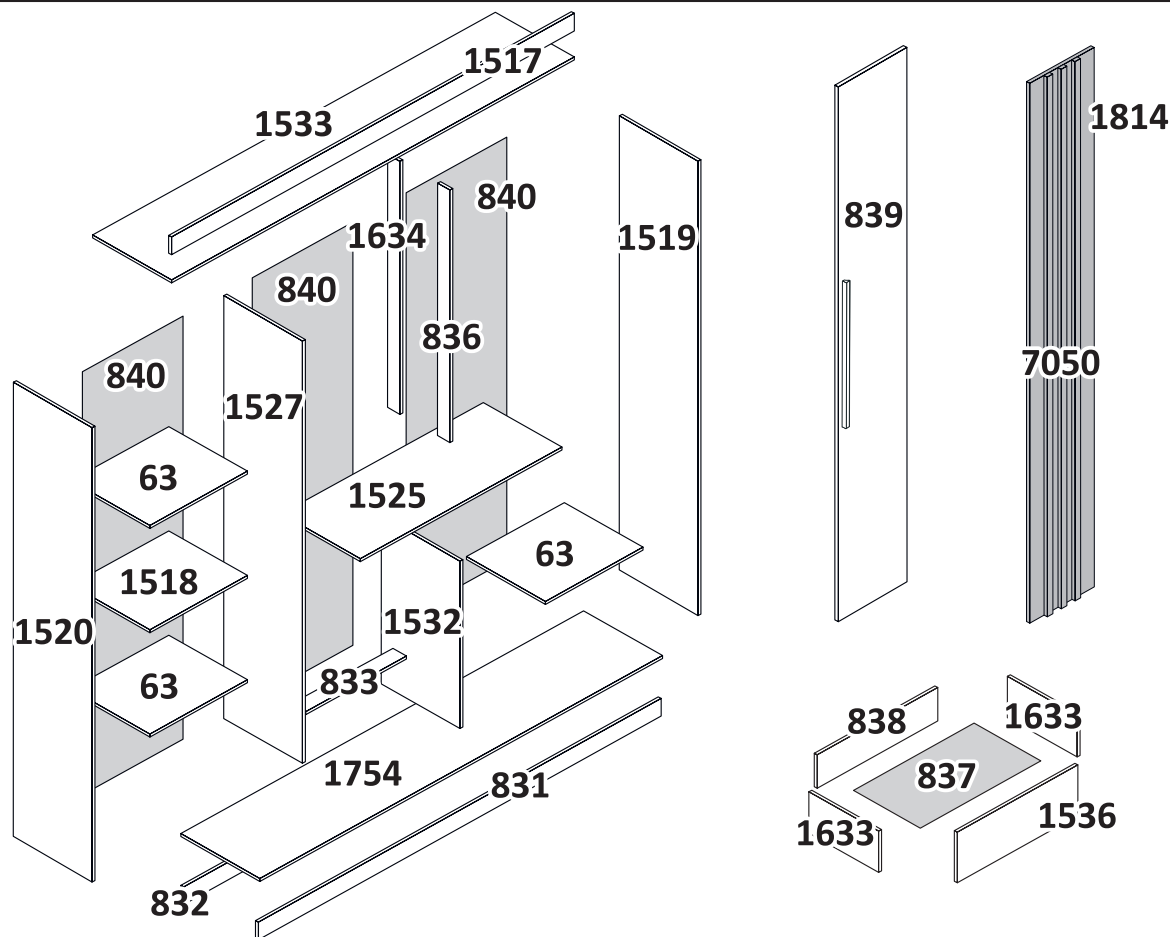

CÓDIGO CODE CODIGO	DESCRIÇÃO DESCRIPTION DESCRIPCIÓN	QTD. QUANTITY CANTIDAD	DIMENSÕES DIMENSIONS DIMENSIONES		
			COMP. LENGTH LONGITUD	LARG. WIDTH ANCHO	CHAPA PLATE LÁMINA
1519	LATERAL DIREITA RIGHT SIDE / LATERAL DERECHA	01	1,994	0,430	12mm
1520	LATERAL ESQUERDA LEFT SIDE / LATERAL IZQUIER	01	1,994	0,430	12mm
1517	RODA FORRO BACKING PANEL / PANEL DE RESPALDO	01	1,806	0,105	12mm
0831	RODAPÉ FRONTAL DFRONT BASEBOARD / ZÓCALO FRONTAL	01	1,794	0,100	12mm
0832	RODAPÉ TRASEIRO BACK BASEBOARD / ZÓCALO TRASERO	01	1,794	0,100	12mm
0833	TRAVESSA CROSSBAR / TRAVESAÑO	01	0,590	0,070	15mm
1533	TAMPO SUPERIOR TOP PANEL / TAPA SUPERIOR	01	1,794	0,430	12mm
1754	TAMPO INFERIOR BOTTOM PANEL / TAPA INFERIOR	01	1,794	0,430	12mm
1525	TAMPO CENTRAL CENTRAL PANEL / TAPA CENTRAL	01	1,192	0,430	12mm
1527	DIVISÓRIA ESQUERDA LEFT DIVIDER / DIVISIÓN IZQUIERDA	01	1,770	0,430	12mm
1532	DIVISÓRIA DIREITA RIGHT DIVIDER / DIVISIÓN DERECHA	01	0,800	0,430	12mm
0063	PRATELEIRA MÓVEL ADJUSTABLE SHELF / REPISA MÓVIL	03	0,590	0,330	12mm
1634	PILASTRA TRASEIRA BACK PILASTER / PILASTRA TRASERA	01	0,958	0,100	12mm
0838	TRASEIRO GAVETA DRAWER BACK / PARTE TRASERA DE CAJÓN	02	0,475	0,070	12mm
1633	LATERAL GAVETA DRAWER SIDE / LATERAL DE CAJÓN	04	0,320	0,085	12mm
1536	FRENTE GAVETA DRAWER FRONT / FRENTE DE CAJÓN	02	0,525	0,158	12mm
1518	PRATELEIRA FIXA FIXED SHELF / ESTANTE FIJA	01	0,590	0,330	12mm
0836	PILASTRA FRONTAL FRONT PILASTER / PILASTRA FRONTAL	01	0,958	0,100	12mm
0837	FUNDO GAVETA DRAWER BOTTOM / FONDO DE CAJÓN	02	0,327	0,495	3mm
0839	PORTA DOOR / PUERTA	06	1,794	0,298	15mm
0840	COSTAS BACK / TRASERA	03	1,805	0,605	3mm
7050	RIPADO SLATTED / RANURADO	06	1,794	0,025	12mm
1814	PORTA RIPADO SLATTED DOOR / PUERTA RANURADO	02	1,794	0,298	15mm

Preparando a Lateral Esquerda.

Preparing Left Side.

Preparante Lateral Izquierda.

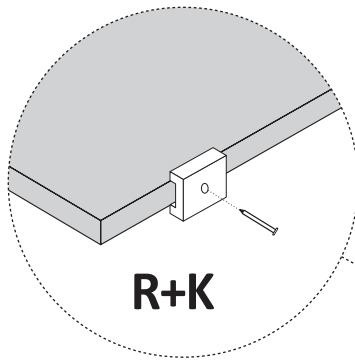
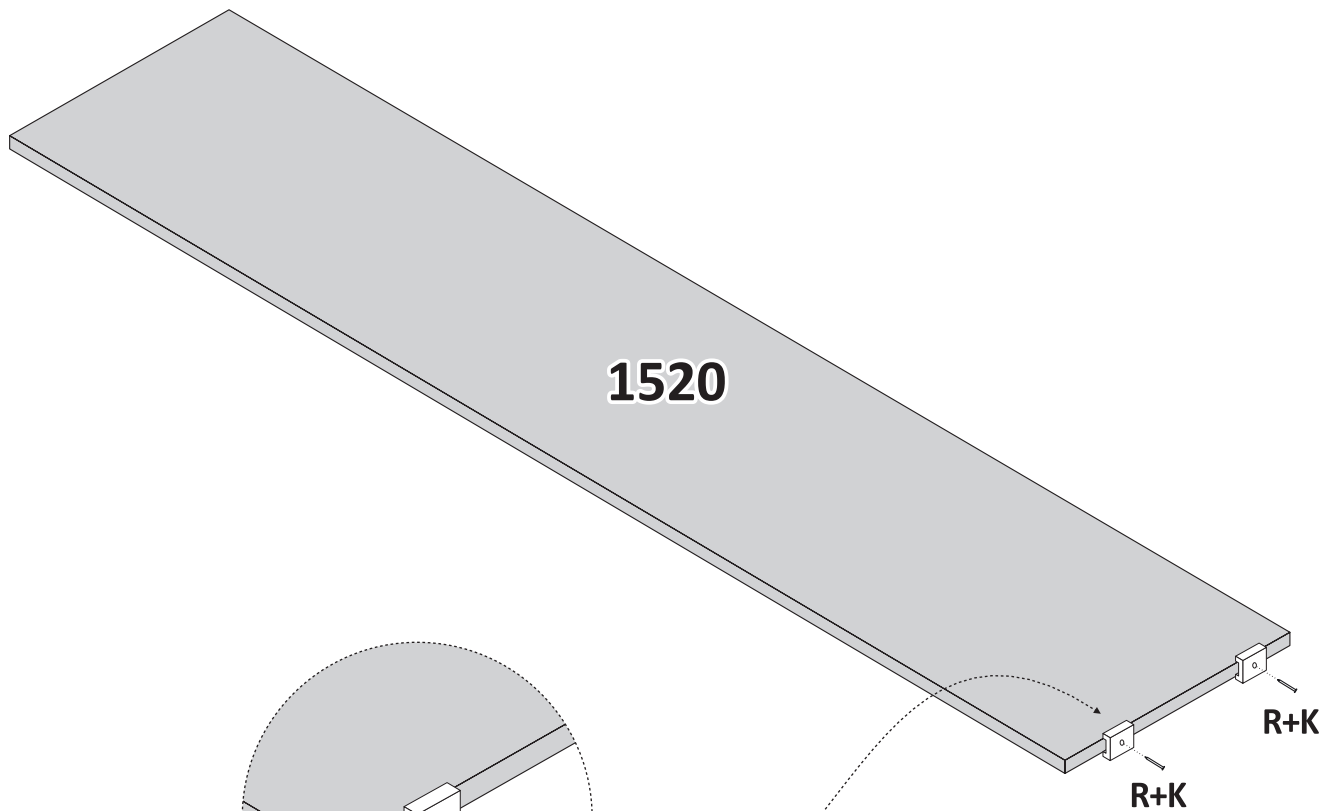

COLOCAÇÃO DAS SAPATAS.

putting on the shoes.
poniéndose los zapatos.

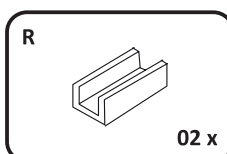
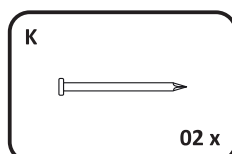

Preparando a Lateral Direita.

Preparing Right Side.

Preparante Lateral Derecha.

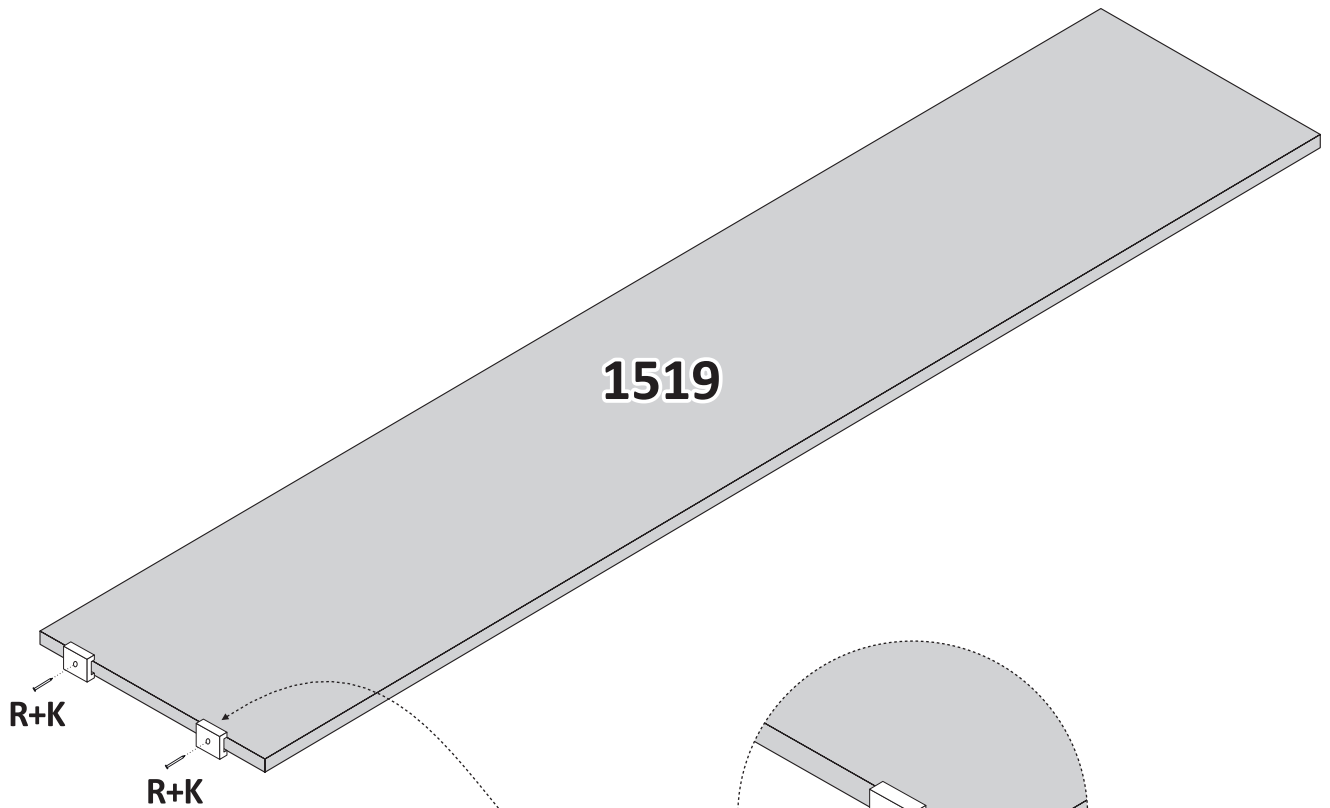

COLOCAÇÃO DAS SAPATAS.

putting on the shoes.
poniéndose los zapatos.

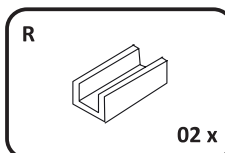
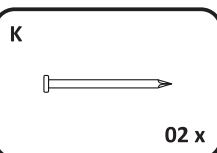

Montando Lateral Esquerda.

Assembly Left Side.

Montaje Lateral Izquierda.

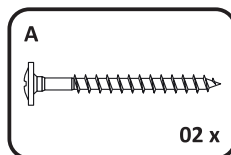
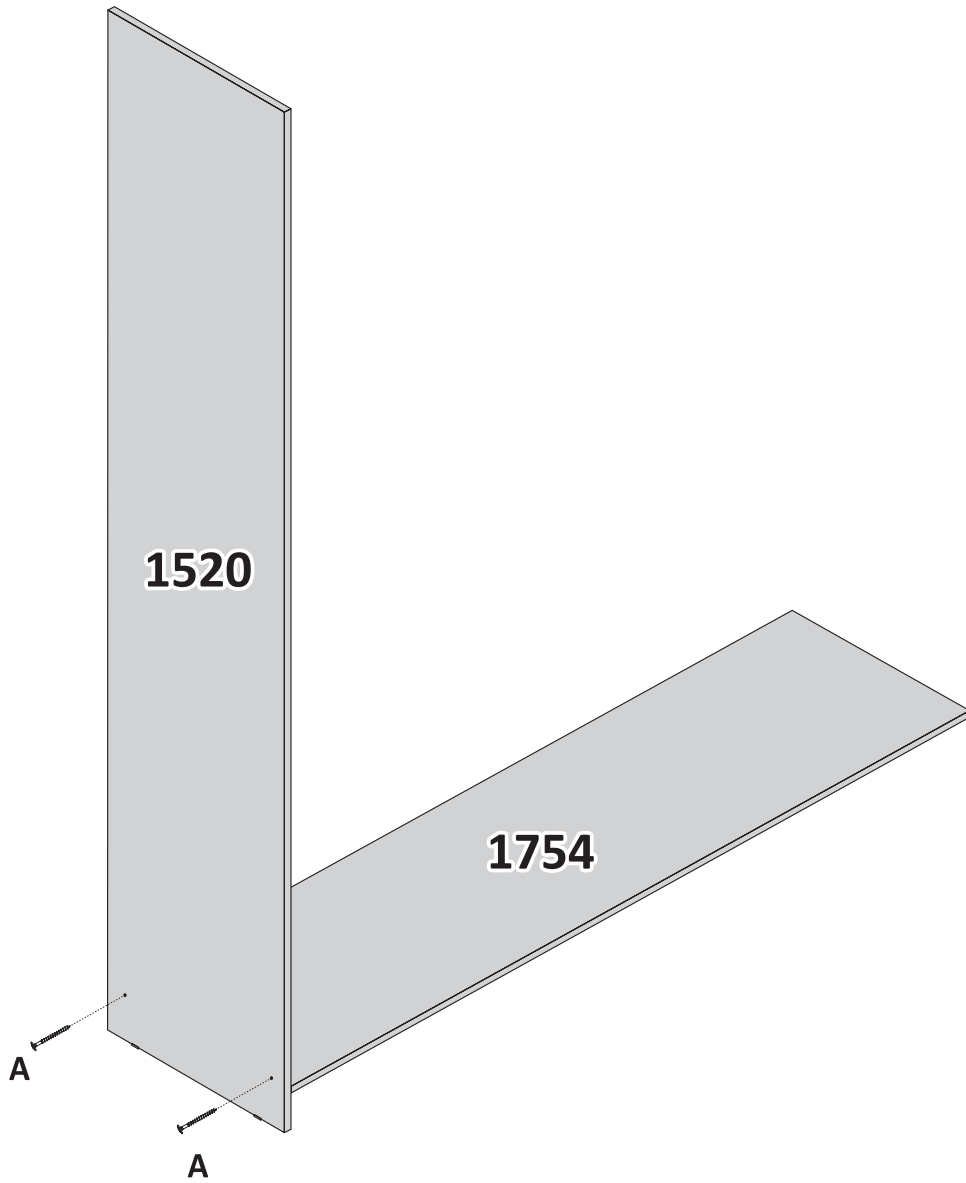

Montando Lateral Direita.

Assembly Right Side.

Montaje Lateral Derecha.

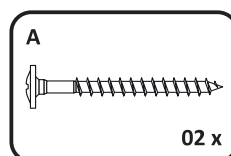
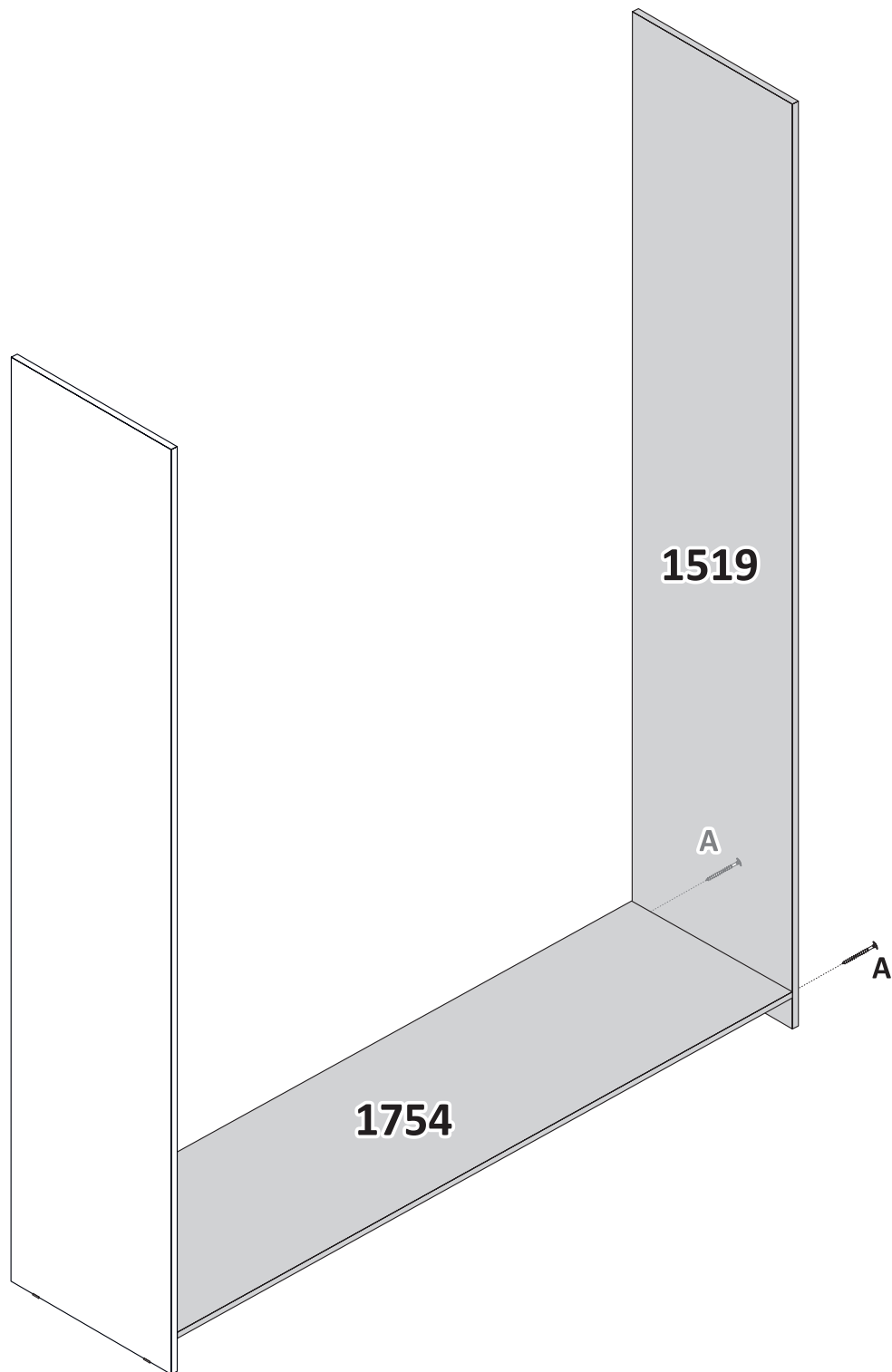

Preparando a Divisão Esquerda.

Preparing Left Divider.

Preparante División Izquierda.

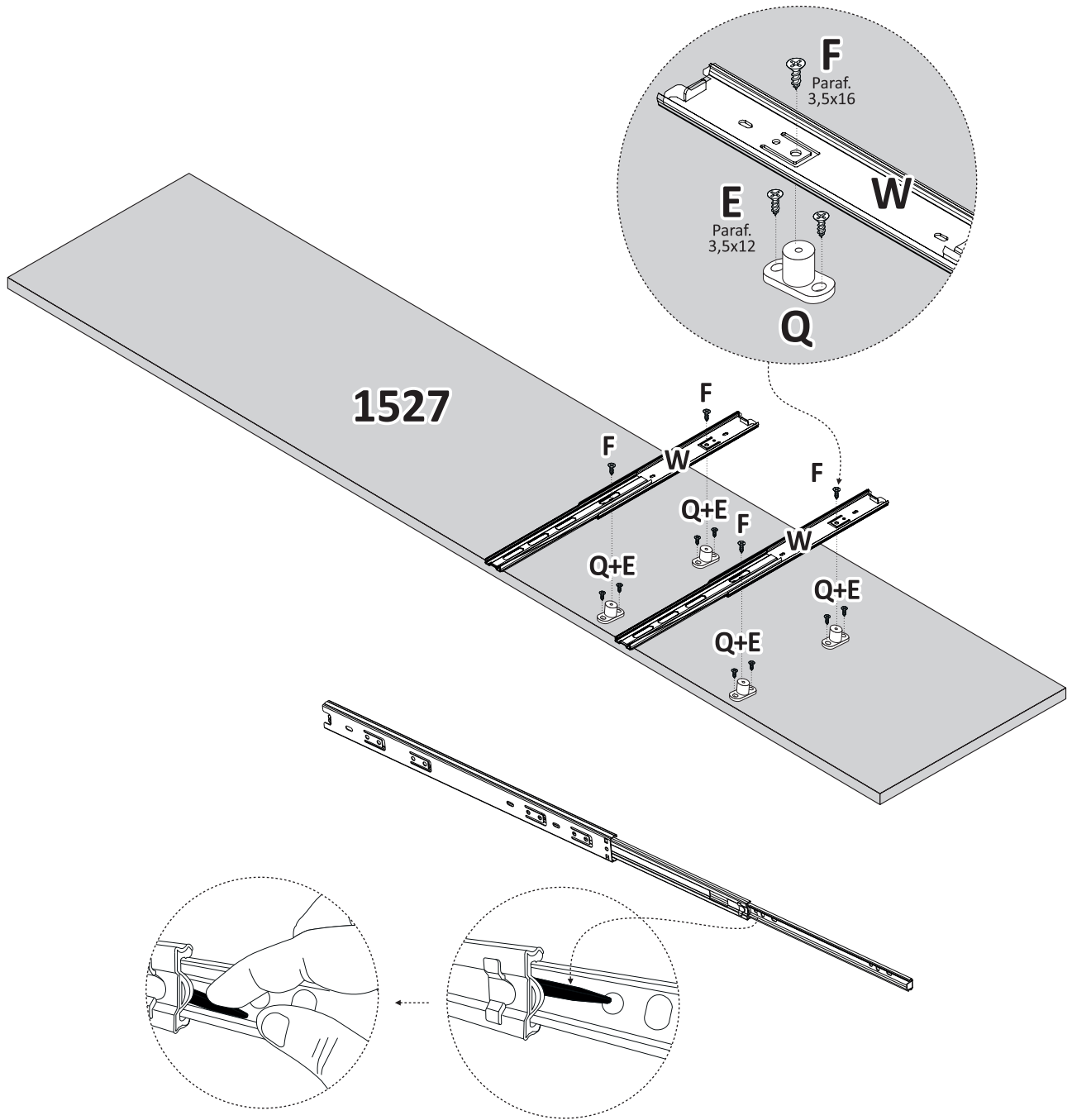

ABAIXE A TRAVA PRETA E RETIRE A PEÇA CONFORME DESENHO ABAIXO.
LOWER THE BLACK LATCH AND REMOVE THE PART AS SHOWN IN THE DRAWING BELOW.
BAJE EL SEGURO NEGRO Y RETIRE LA PIEZA SEGÚN EL DIBUJO DE ABAJO.

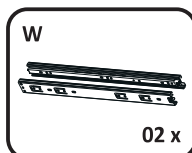
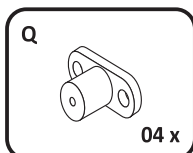
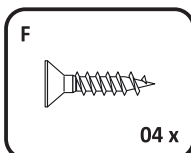
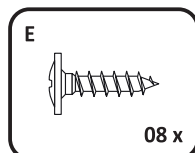

Preparando a Divisão Central.

Preparing Central Divider.

Preparante División Central.

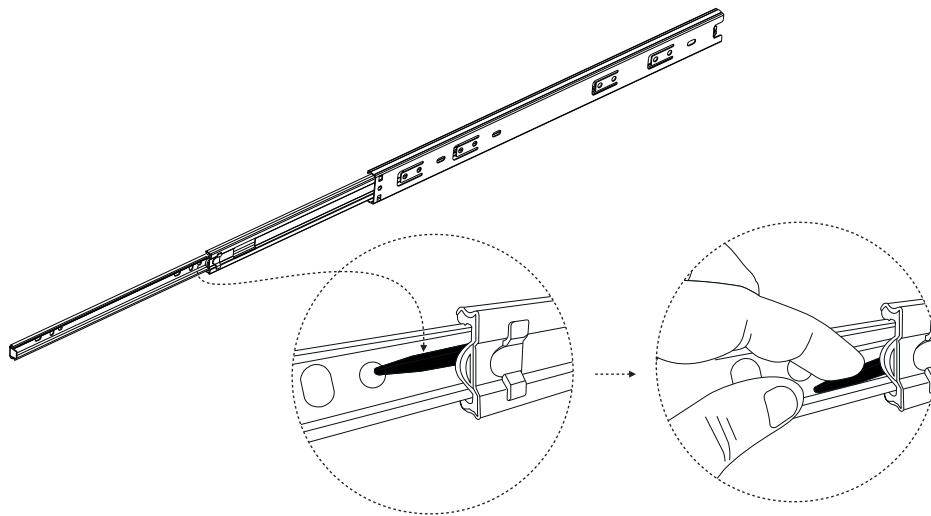
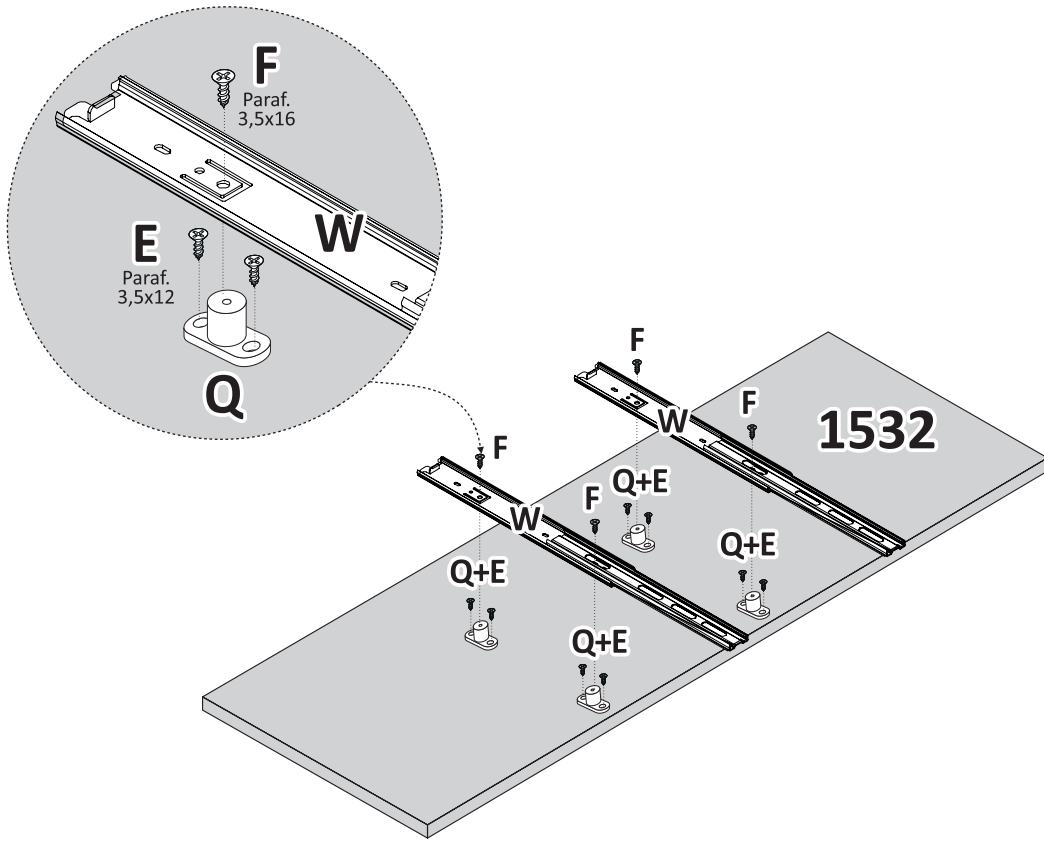

ABAIXE A TRAVA PRETA E RETIRE A PEÇA CONFORME DESENHO ABAIXO.

LOWER THE BLACK LATCH AND REMOVE THE PART AS SHOWN IN THE DRAWING BELOW.

BAJE EL SEGURO NEGRO Y RETIRE LA PIEZA SEGÚN EL DIBUJO DE ABAJO.

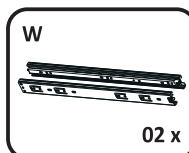
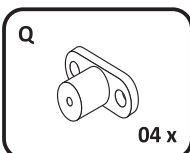
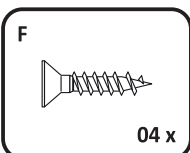
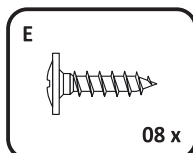

Montar as Divisões.

Assembly Divider.
Montaje División.

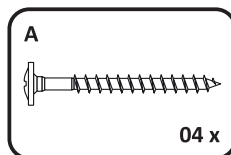
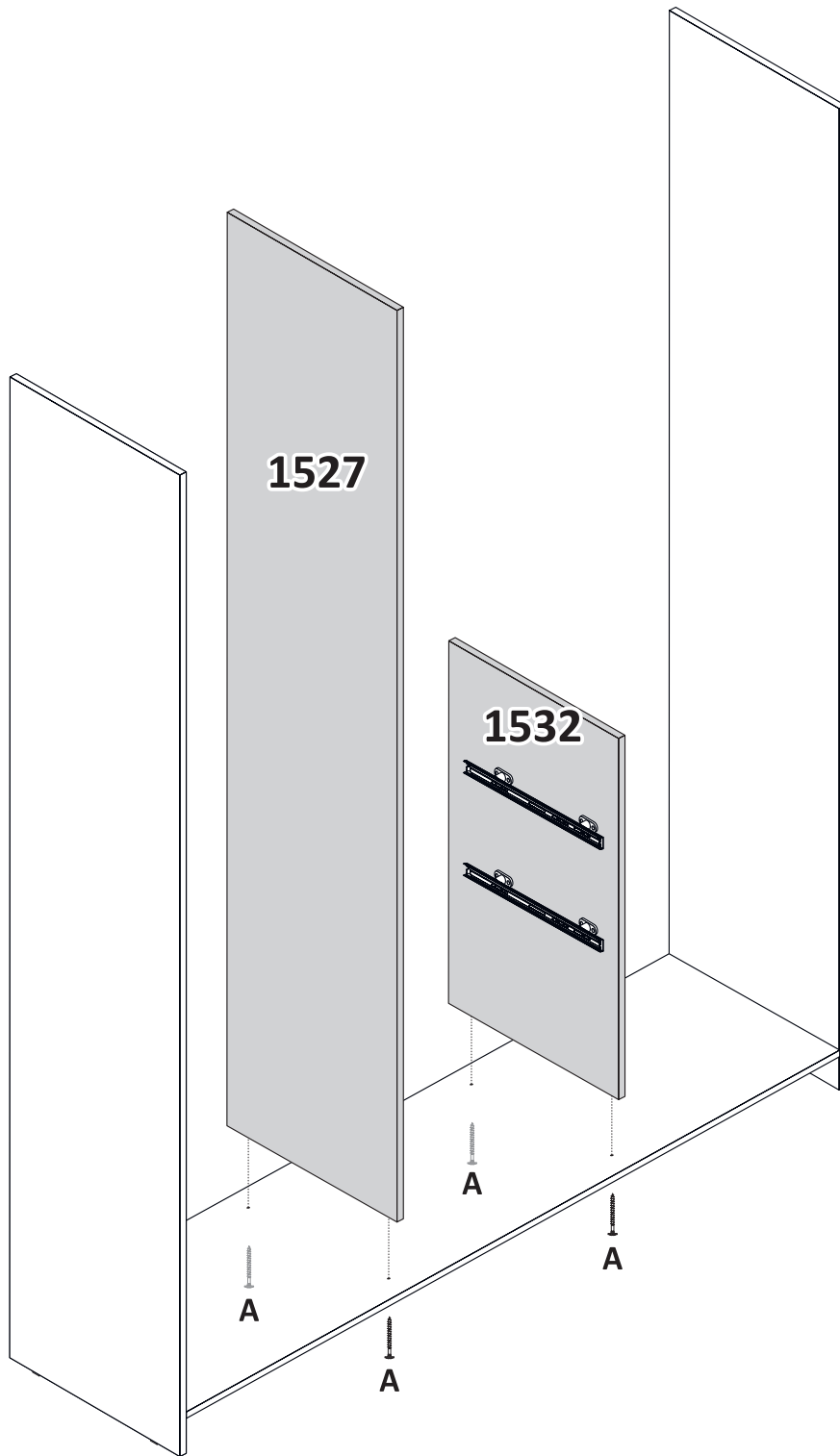

Preparando Rodapé.

Preparing Baseboard.
Preparando Zócalo.

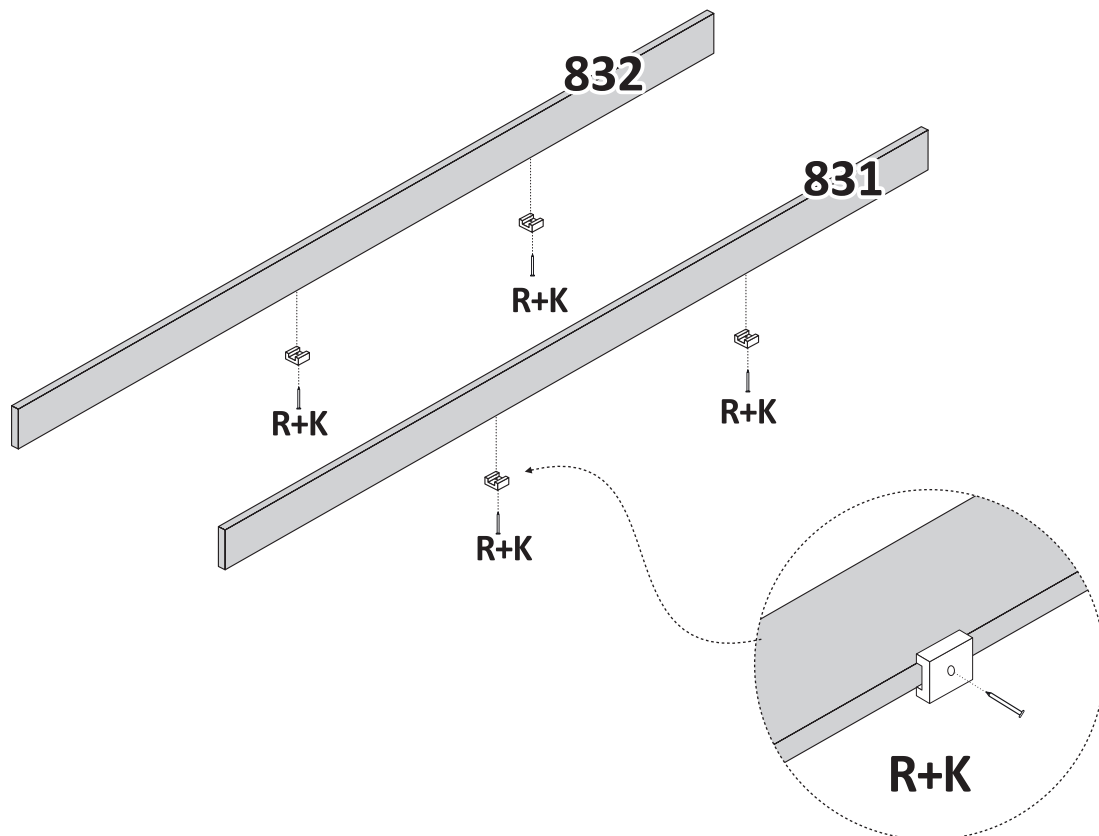

COLOCAÇÃO DAS SAPATAS.

putting on the shoes.
poniéndose los zapatos.

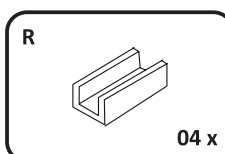
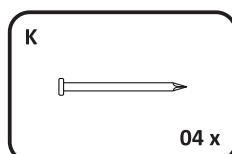

Montar Rodapé.
Assembly Baseboard.
Montaje Zócalo.

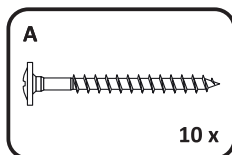
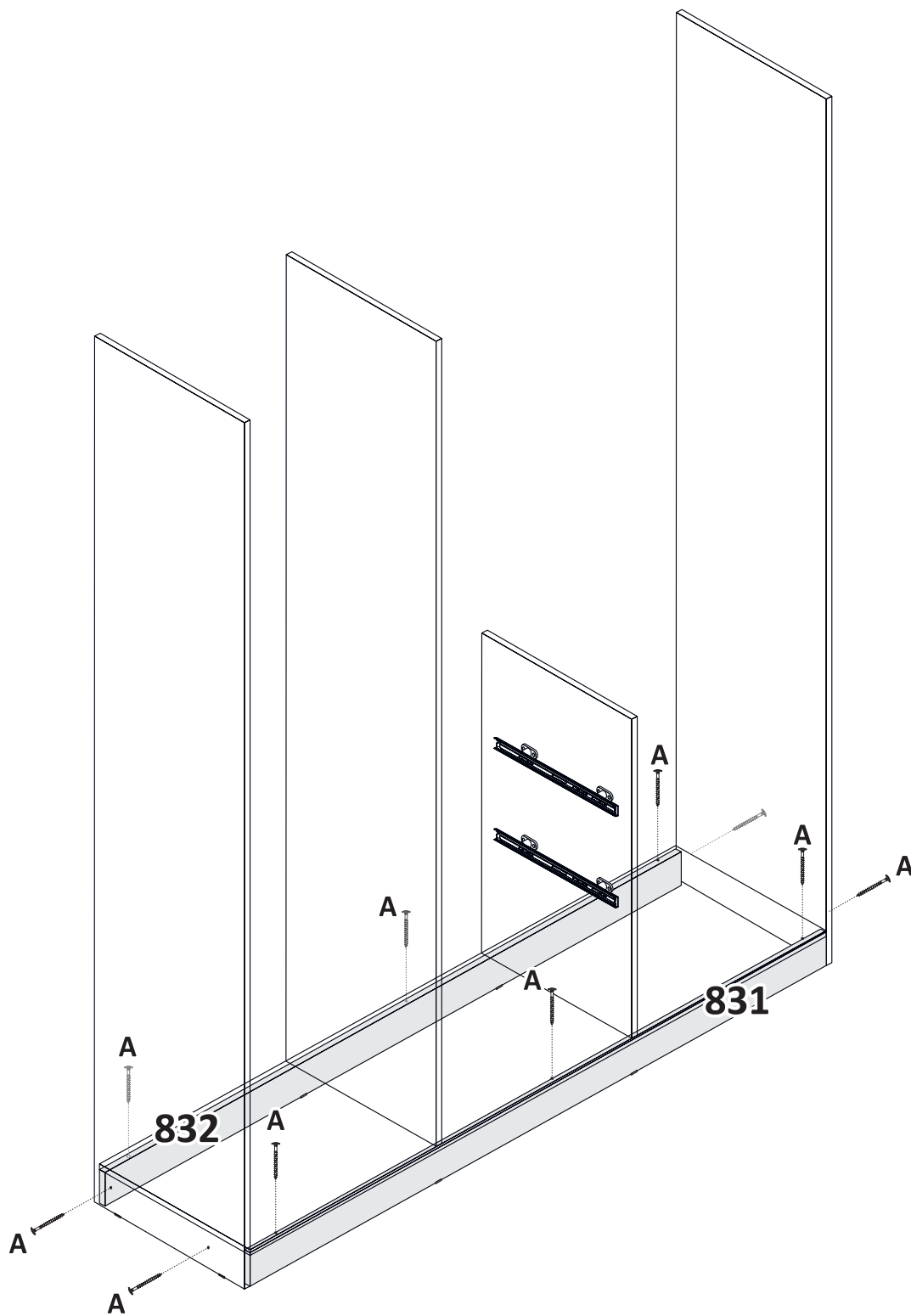

Preparando Tampo Central.

Preparing Central Panel.
Preparando Tapa Central

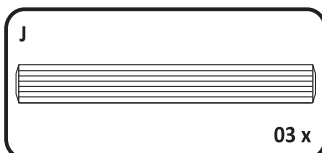
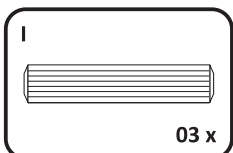
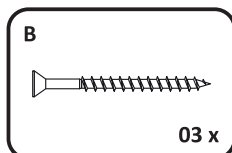
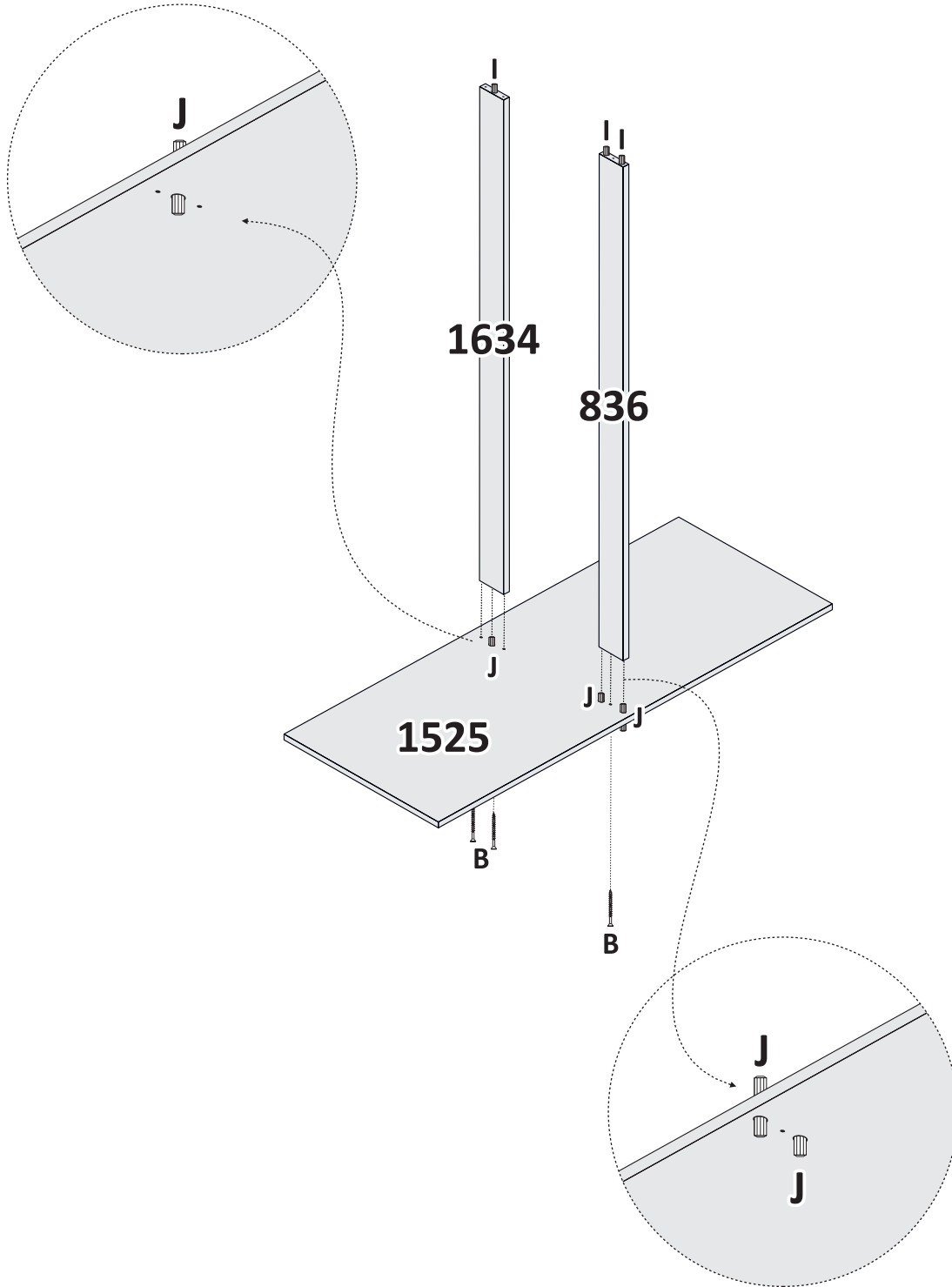

Montando Tampo Central.

Assembly Central Panel.
Montaje Tapa Central.

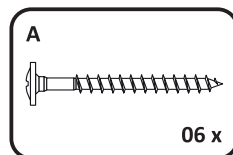
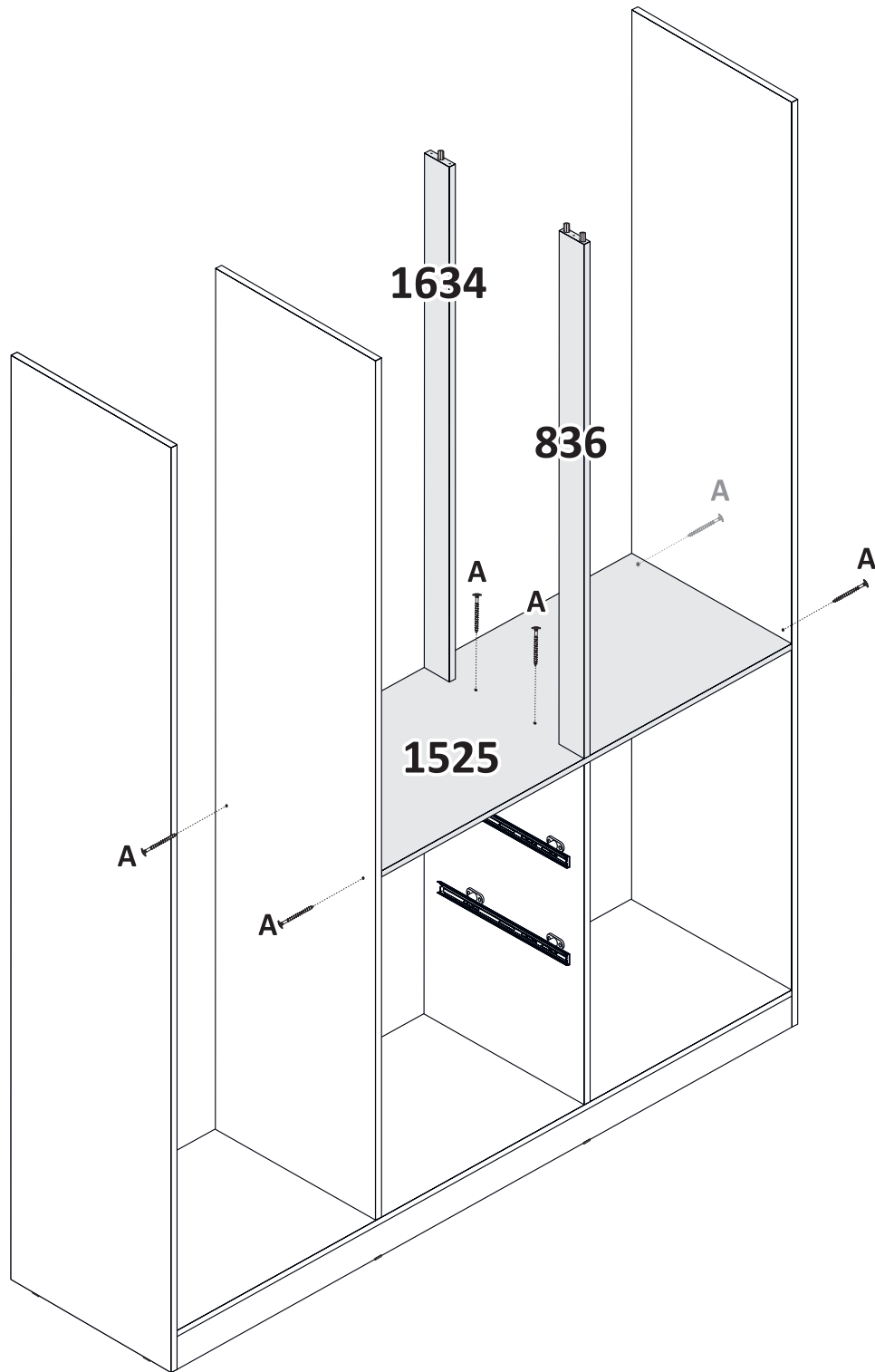

Montando Prateleiras Furadas e Travessas.

Assembling Perforated Shelves and Crossbars.
Montaje de Estantes Perforados y Travesaños.

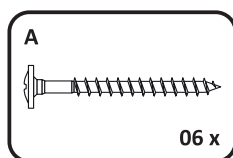
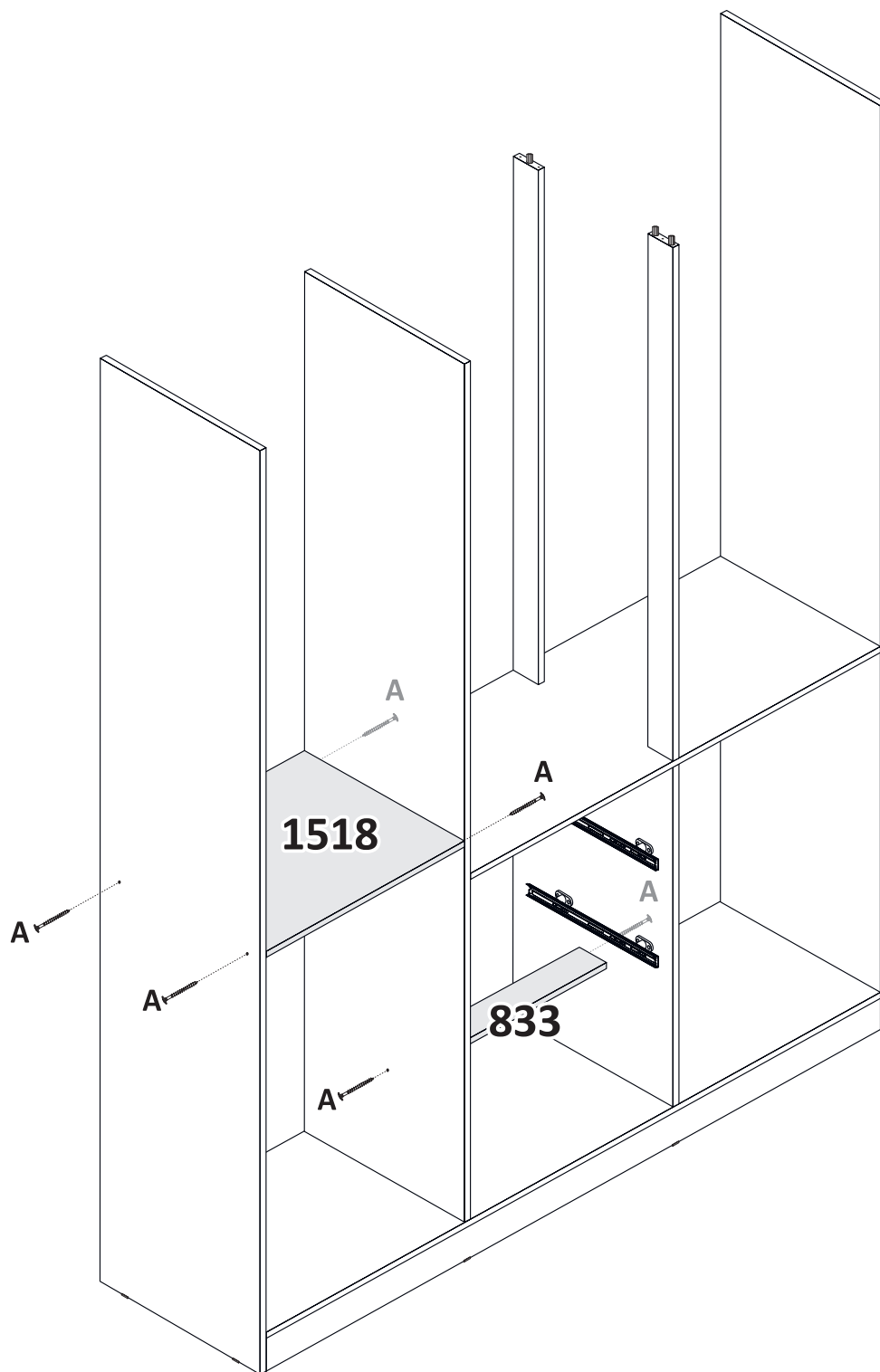

Montagem Tampo.

Hive Top.
Estante Tapa.

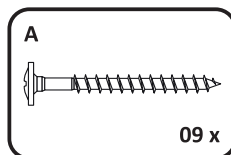
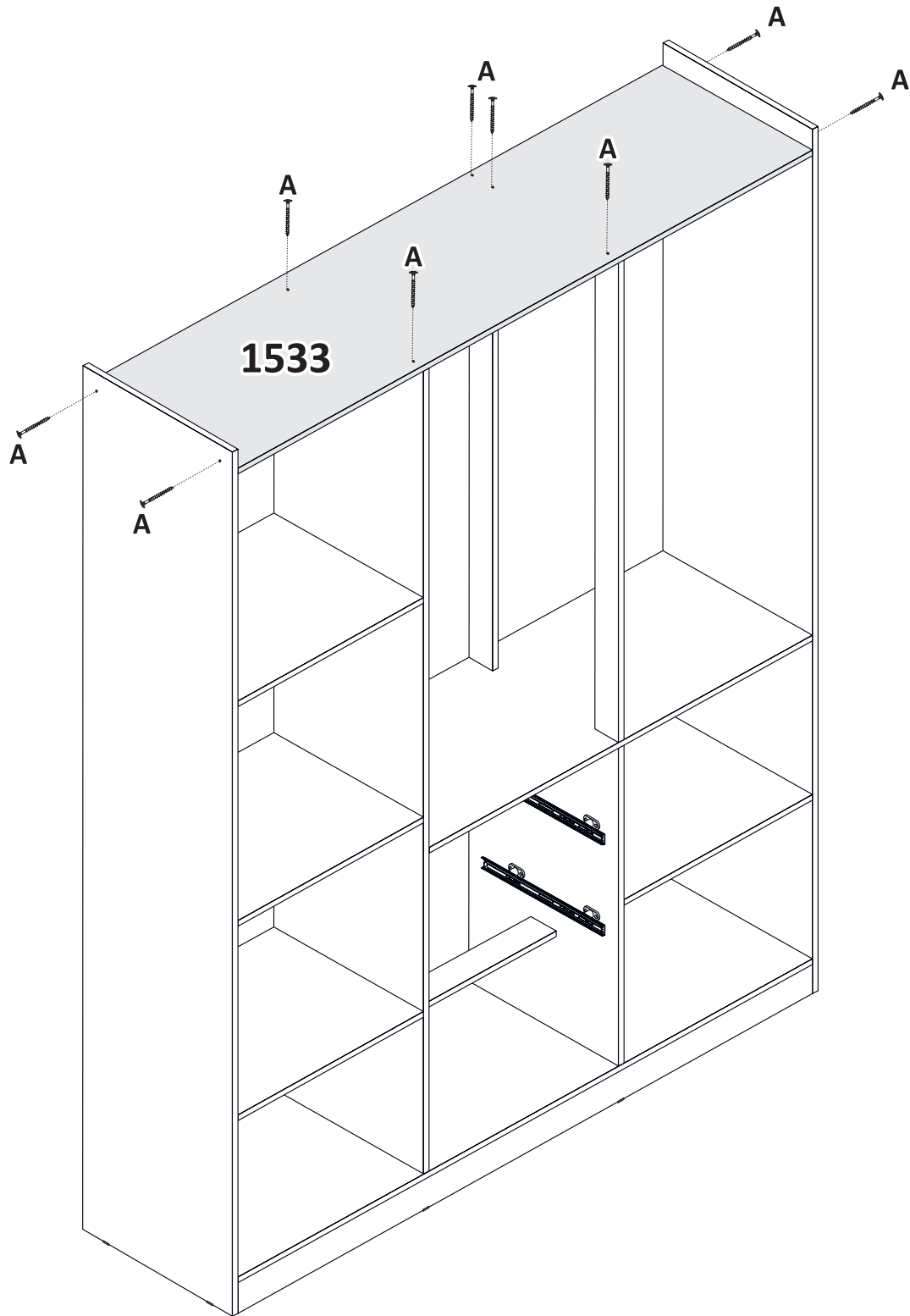

Montagem Rodaforro.

Assembly Rodaforro.
Montaje de Rodaforro.

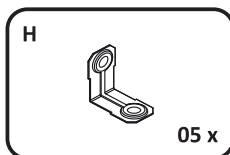
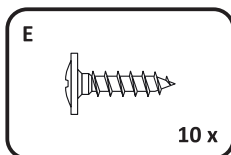
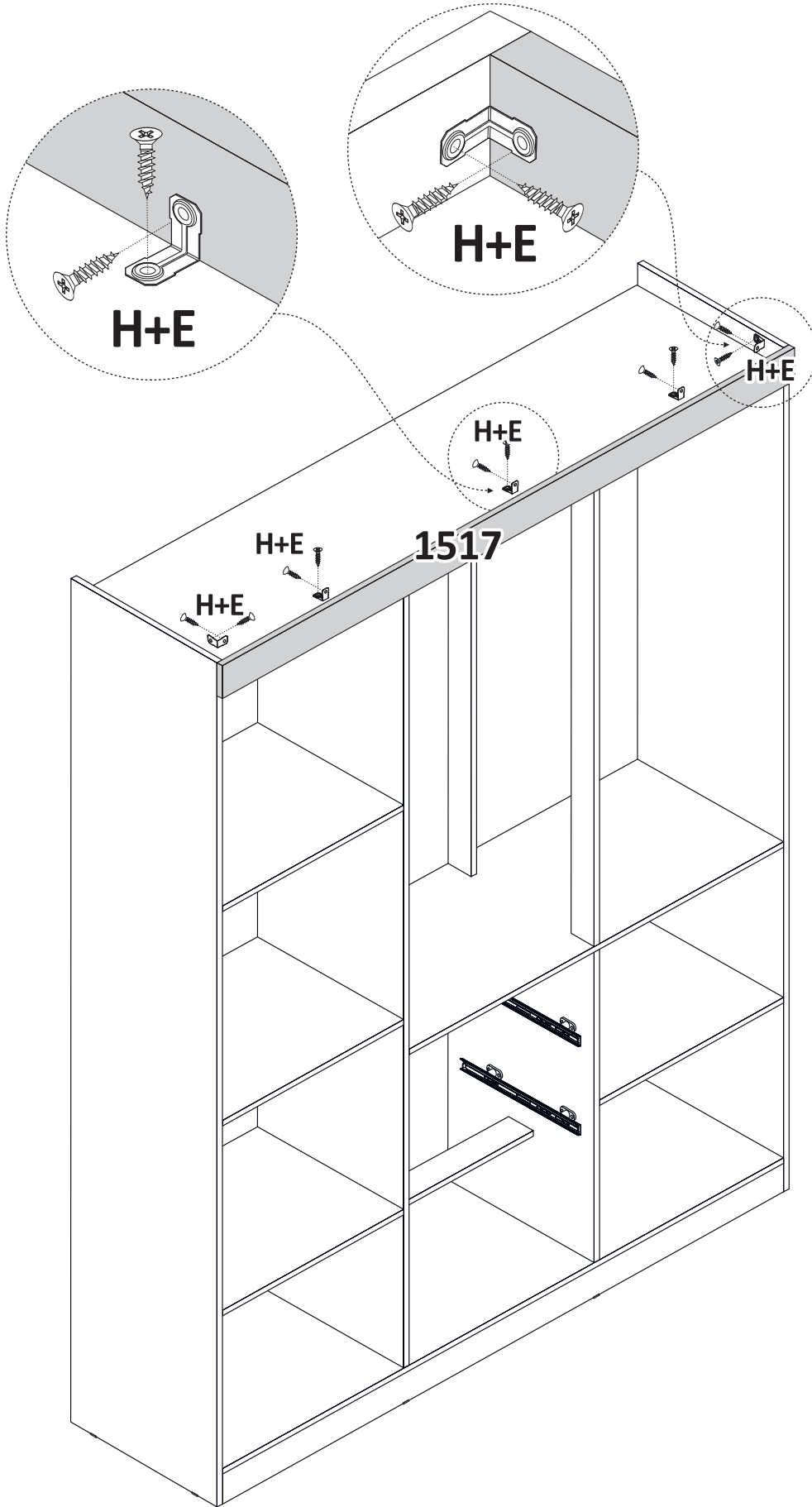

Montagem das Costas.

Back Assembly.
Montaje Trasero.

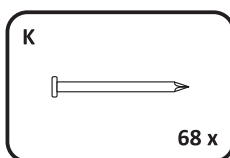
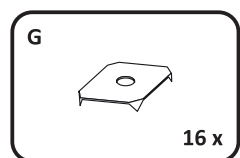
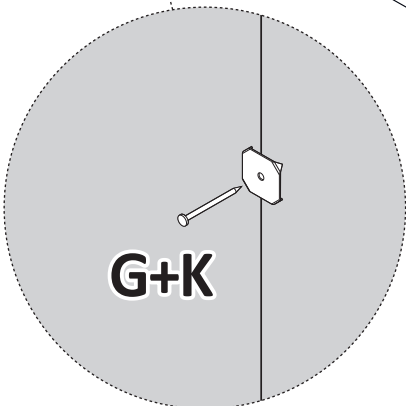
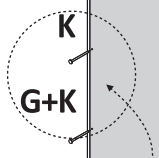
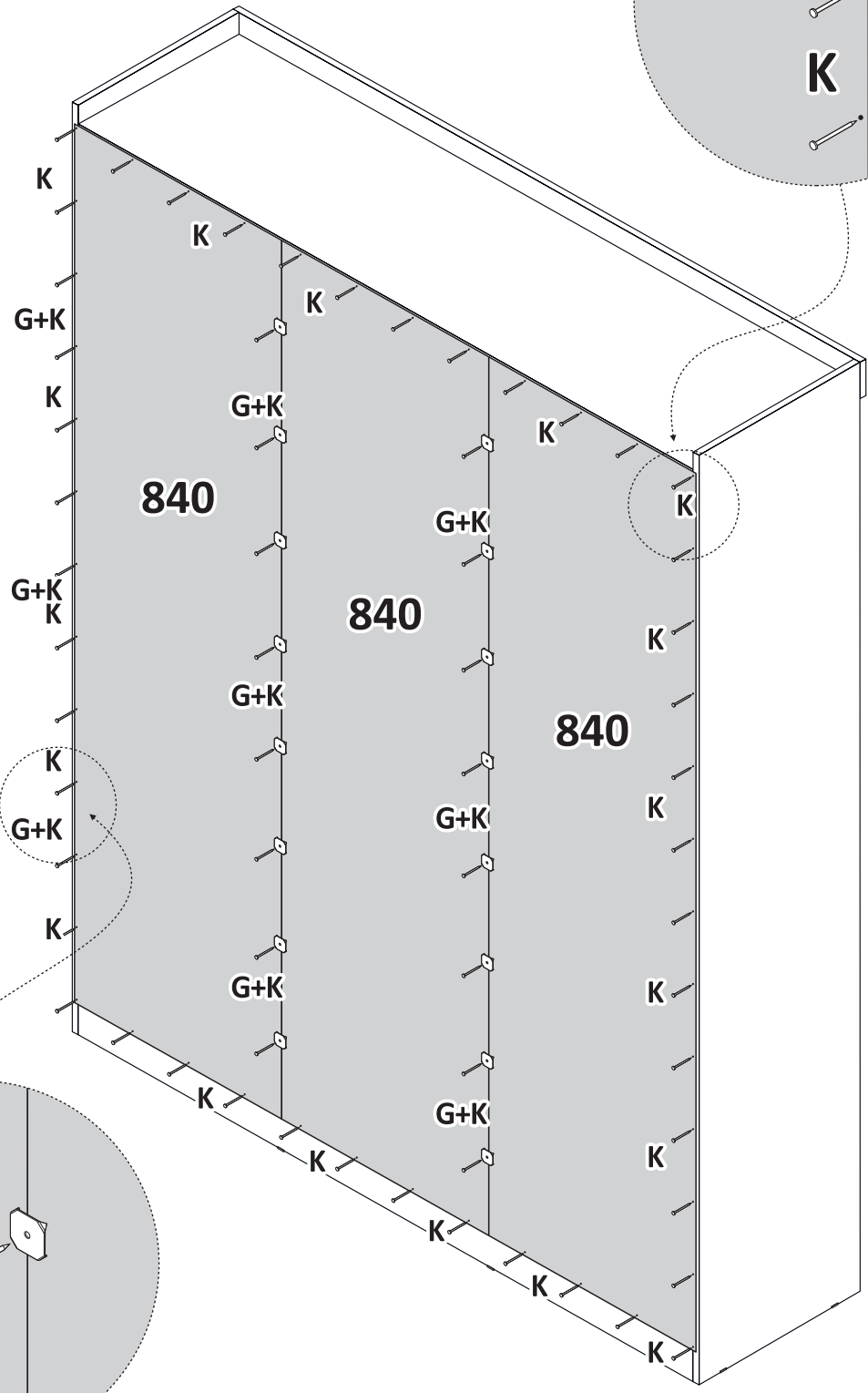
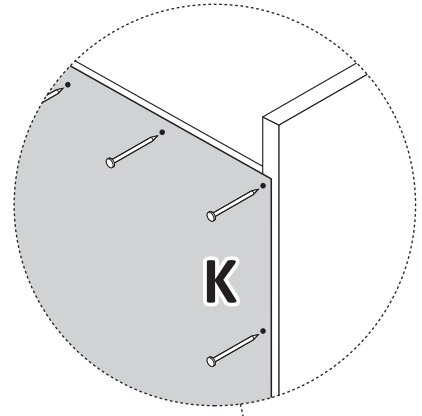

Montar Prateleiras Móveis.

Assemble Mobile Shelves.
Montar Estantes Móveis.

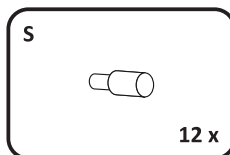
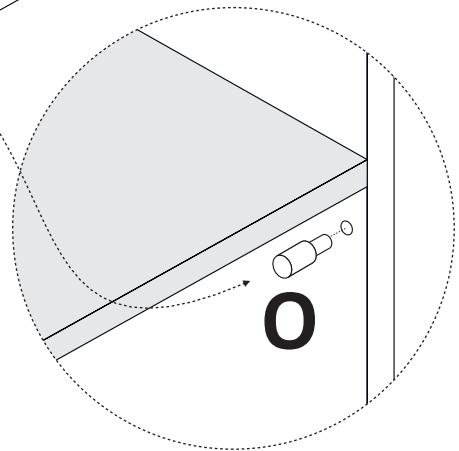
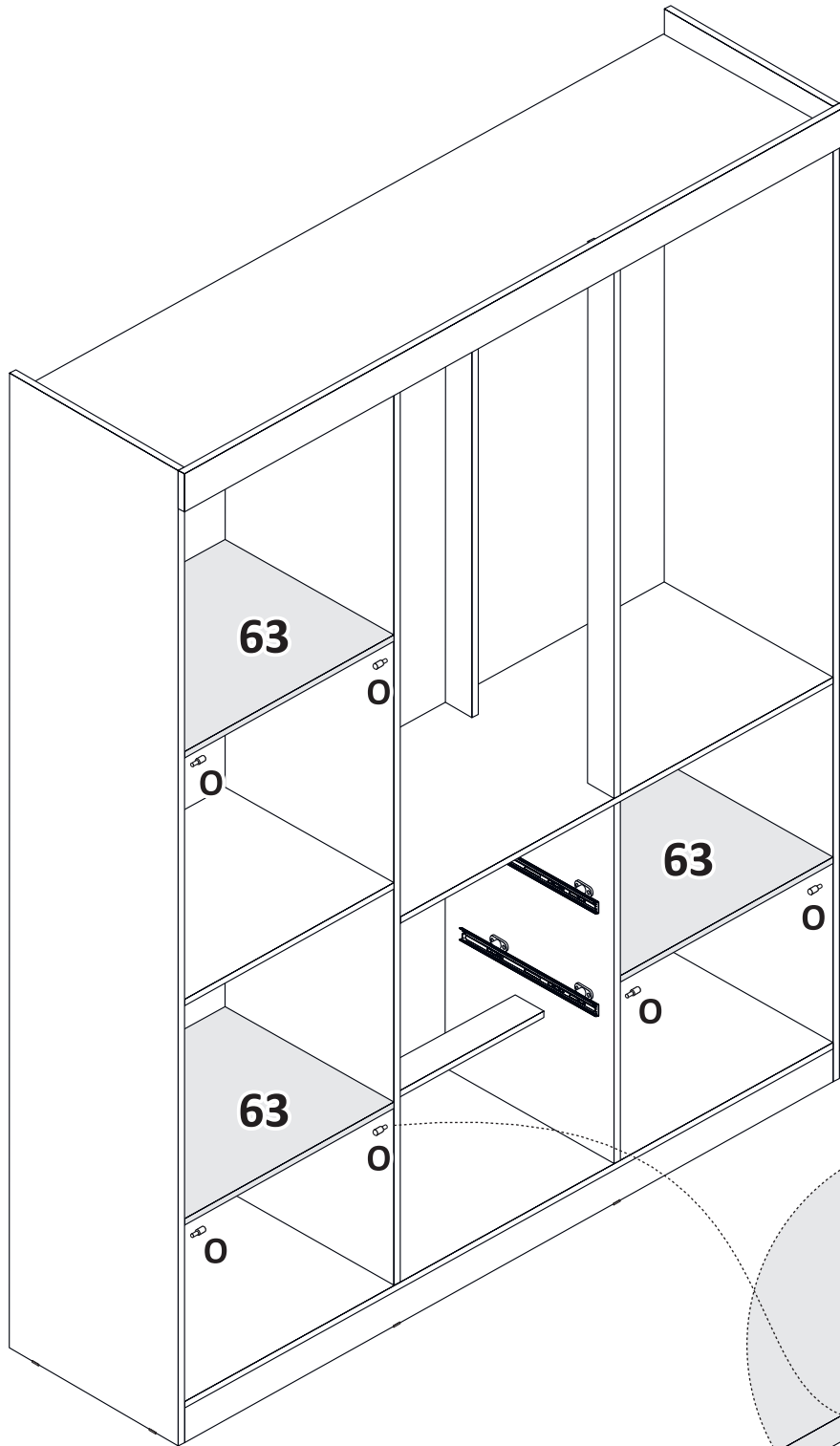

Montar Cabideiro.

Assemble Clothes Rack.
Montar Perchero.

PRIMEIRO MONTAR O SUPORTE CENTRAL, SÓ DEPOIS OS SUPORTES LATERAIS.

FIRST ASSEMBLE THE CENTER SUPPORT, ONLY THEN THE SIDE SUPPORTS.

PRIMERO MONTE EL SOPORTE CENTRAL, SÓ DESPUÉS LOS SOPORTES LATERALES.

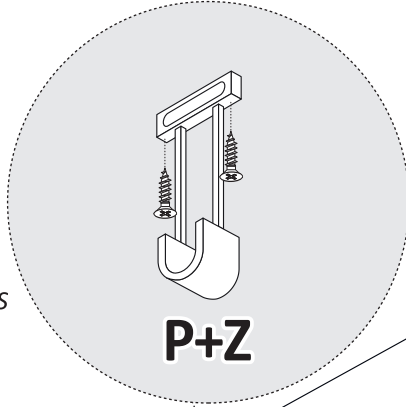

P+Z

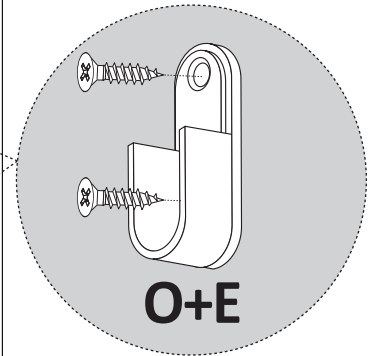
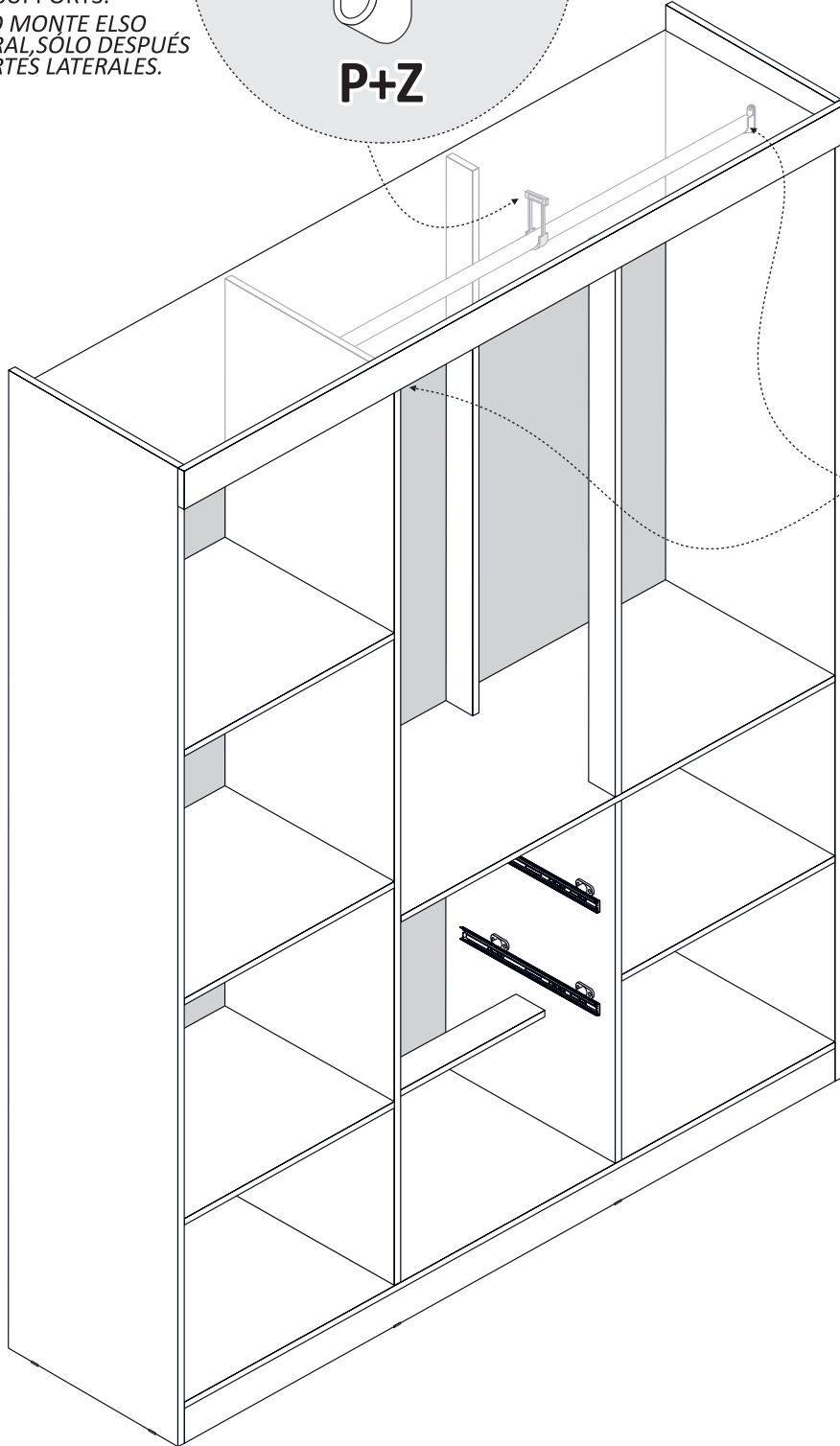

O+E

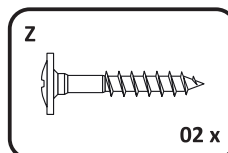
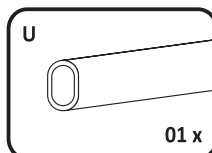
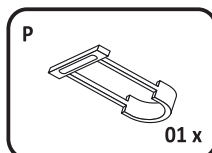
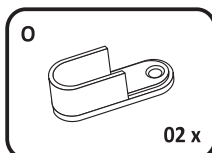
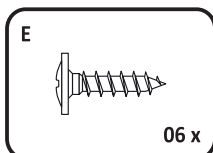

Peso suportado em cada parte.

Weight supported on each part.

Peso soportado en cada parte.

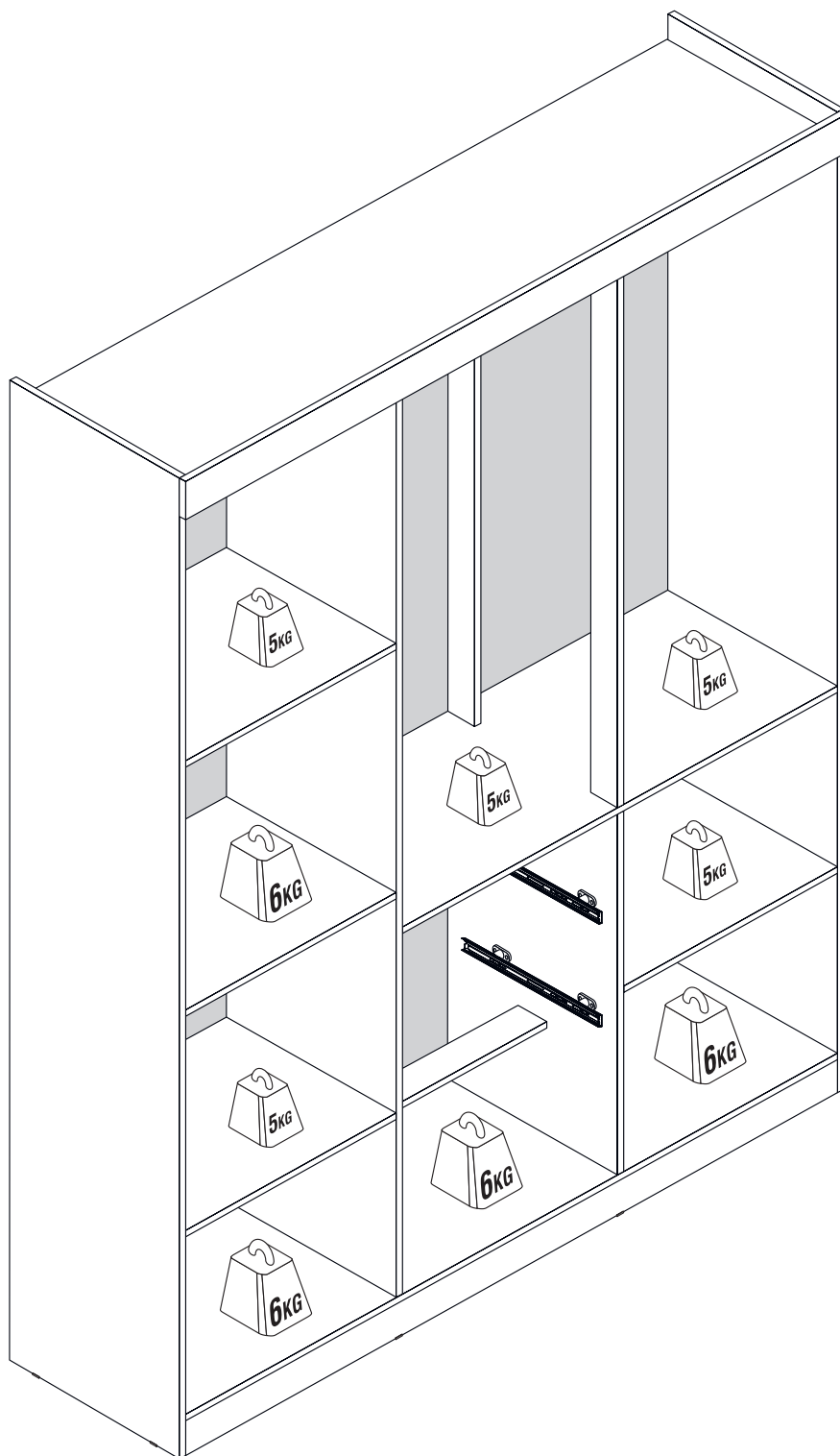

Medidas espaços internos.

Internal spaces measurements.

Medidas del espacios interiores.

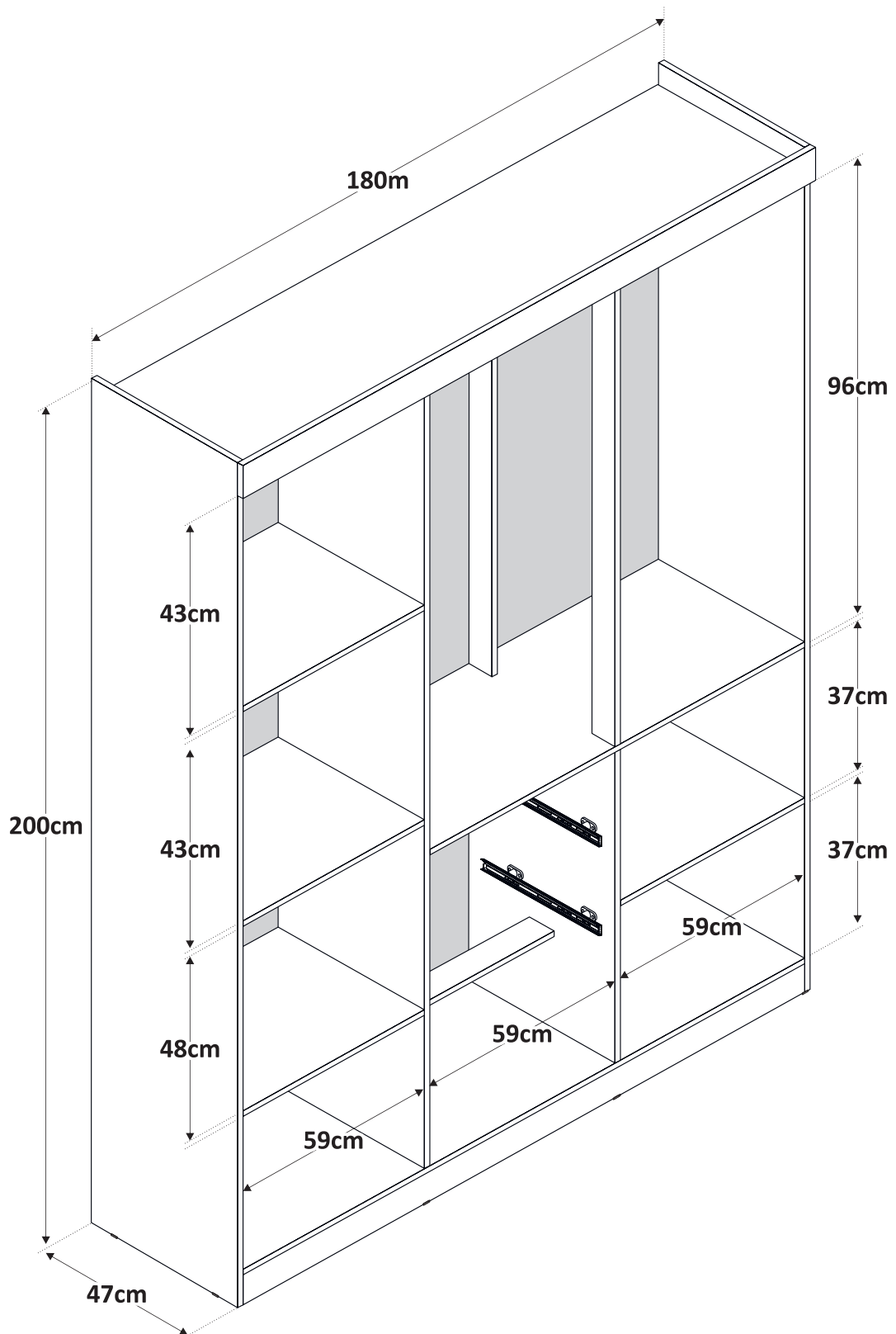

Montagem Porta Esquerda.

Left Door Assembly.

Montaje de la Puerta Izquierda.

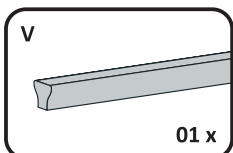
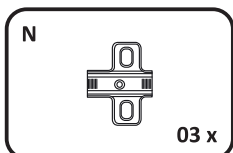
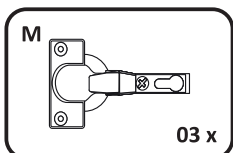
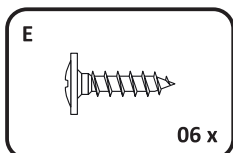
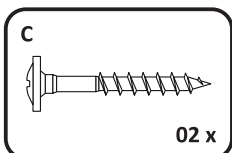
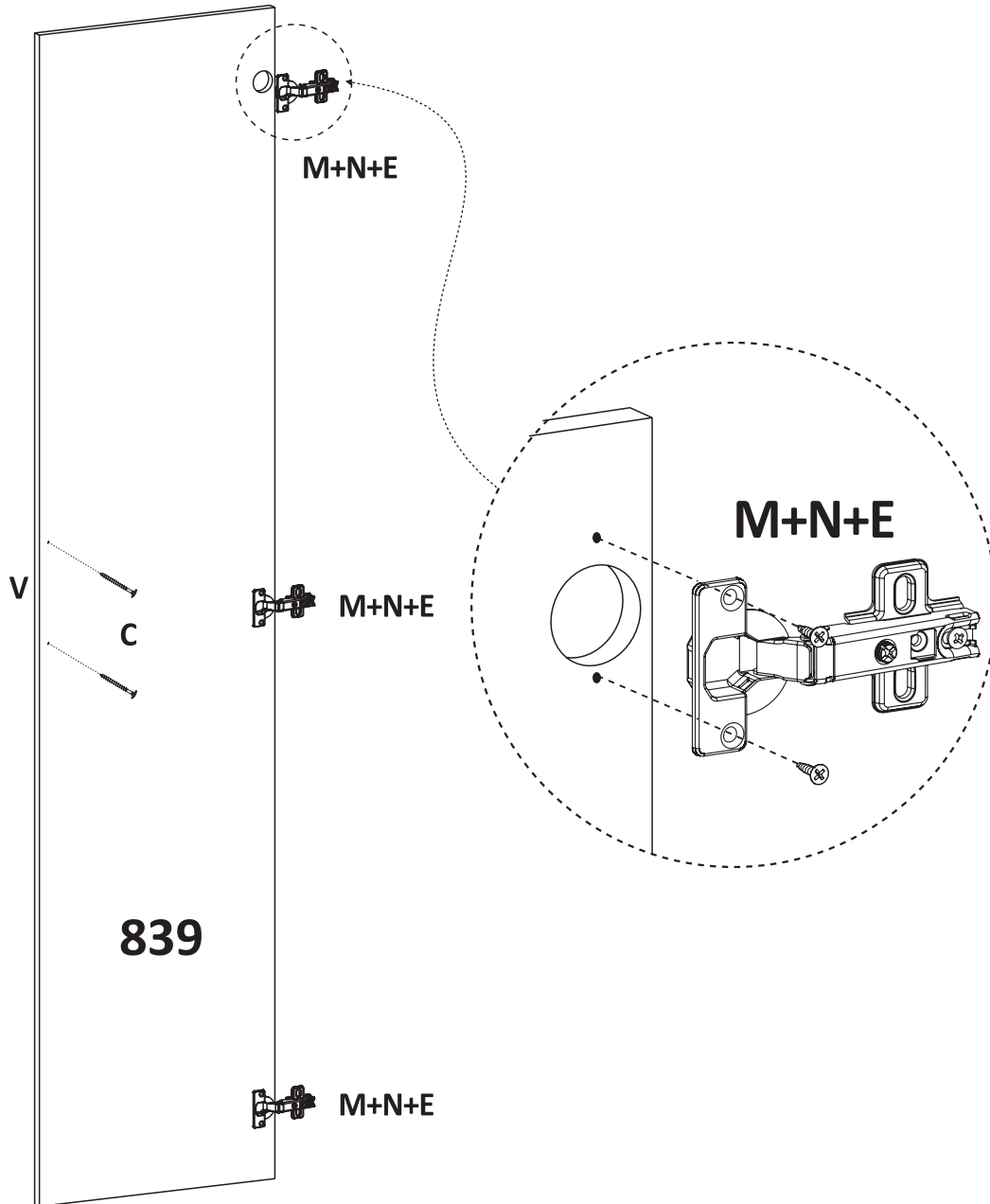

Montagem Porta Direita.

Right Door Assembly.

Montaje de la Puerta Derecha.

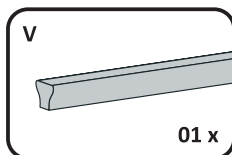
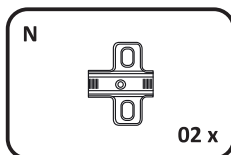
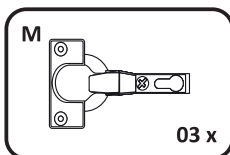
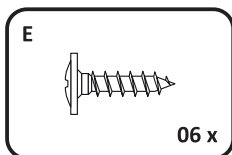
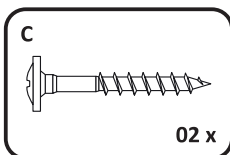
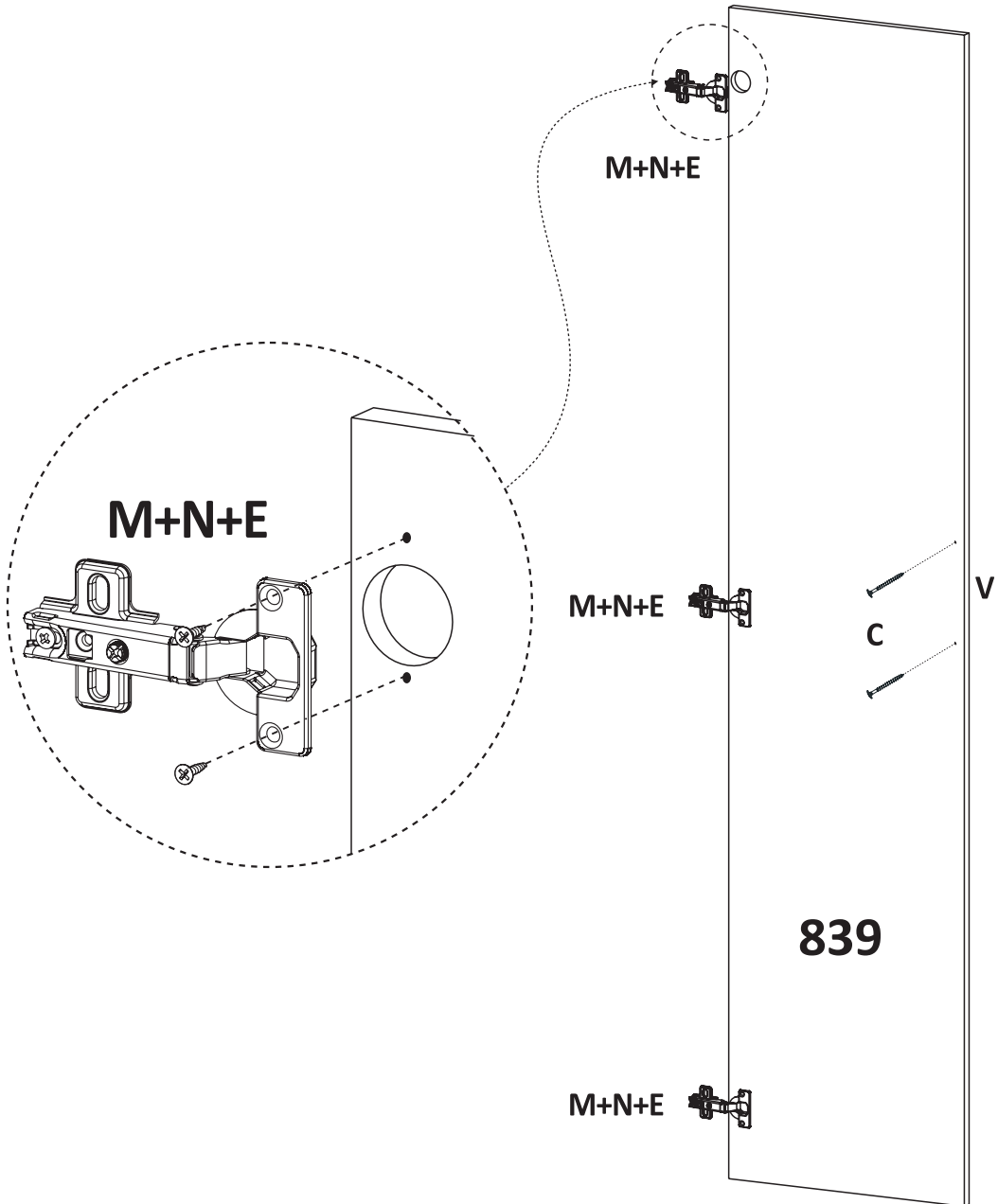

Montagem Kit Espelho Opcional.

Optional Mirror Kit Assembly.
Montaje de Kit Espejo Opcional.

Espelho Opcional.

Optional Mirror
Espejo Opcional.



NÃO UTILIZAR PARAFUSADEIRA

DO NOT USE A SCREWDRIVER
No utilice un destornillador

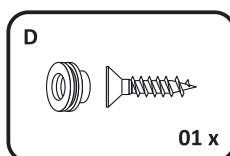
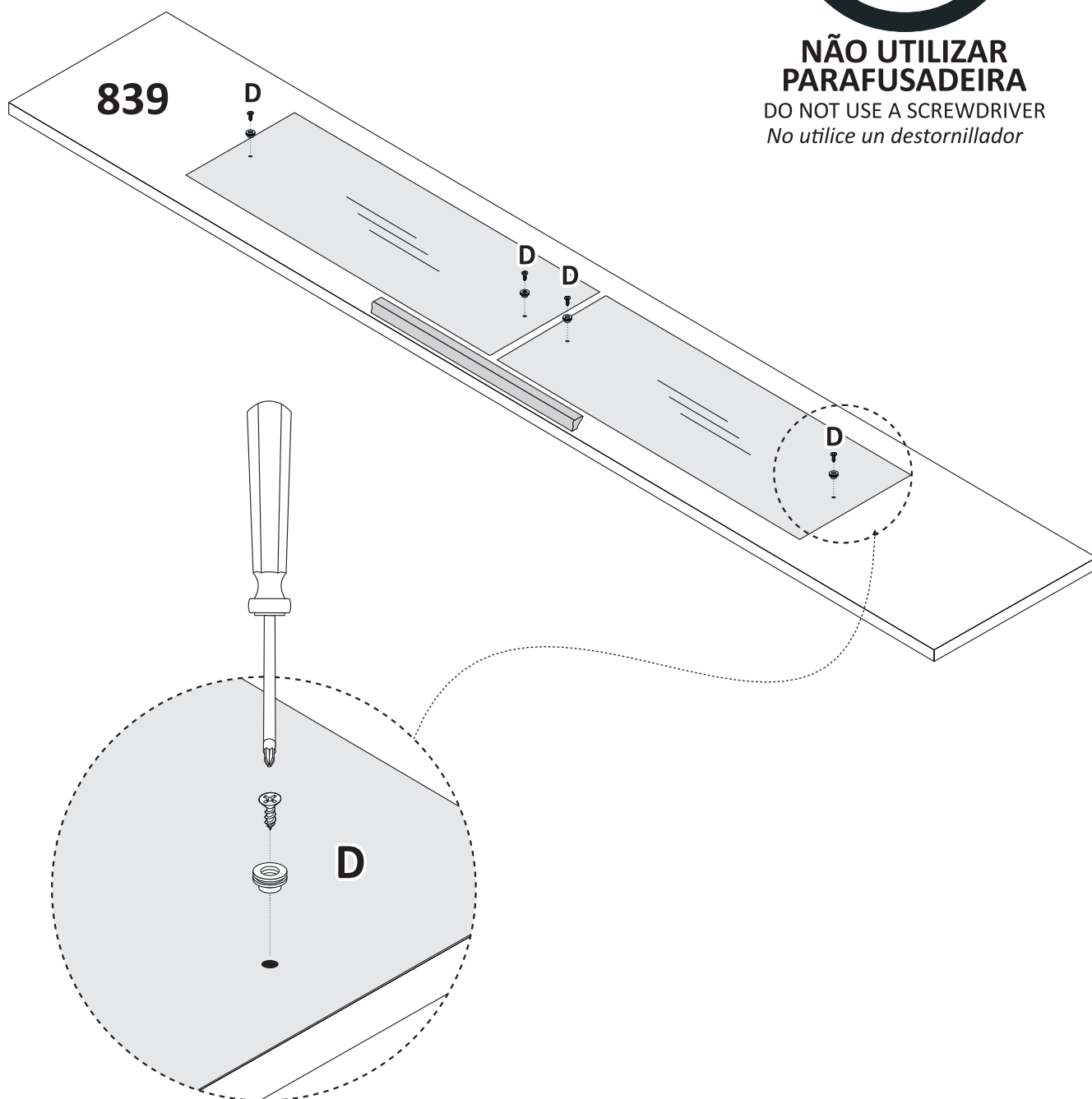

Montagem do Ripado.

Assembly Slatted.

Montaje de Ranurado.



**NÃO UTILIZAR
PARAFUSADEIRA**
DO NOT USE A SCREWDRIVER
No utilice un destornillador

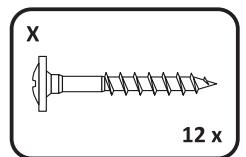
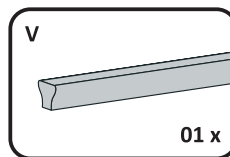
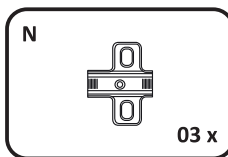
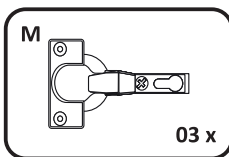
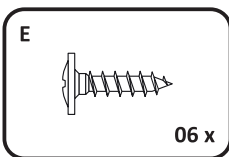
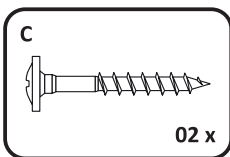
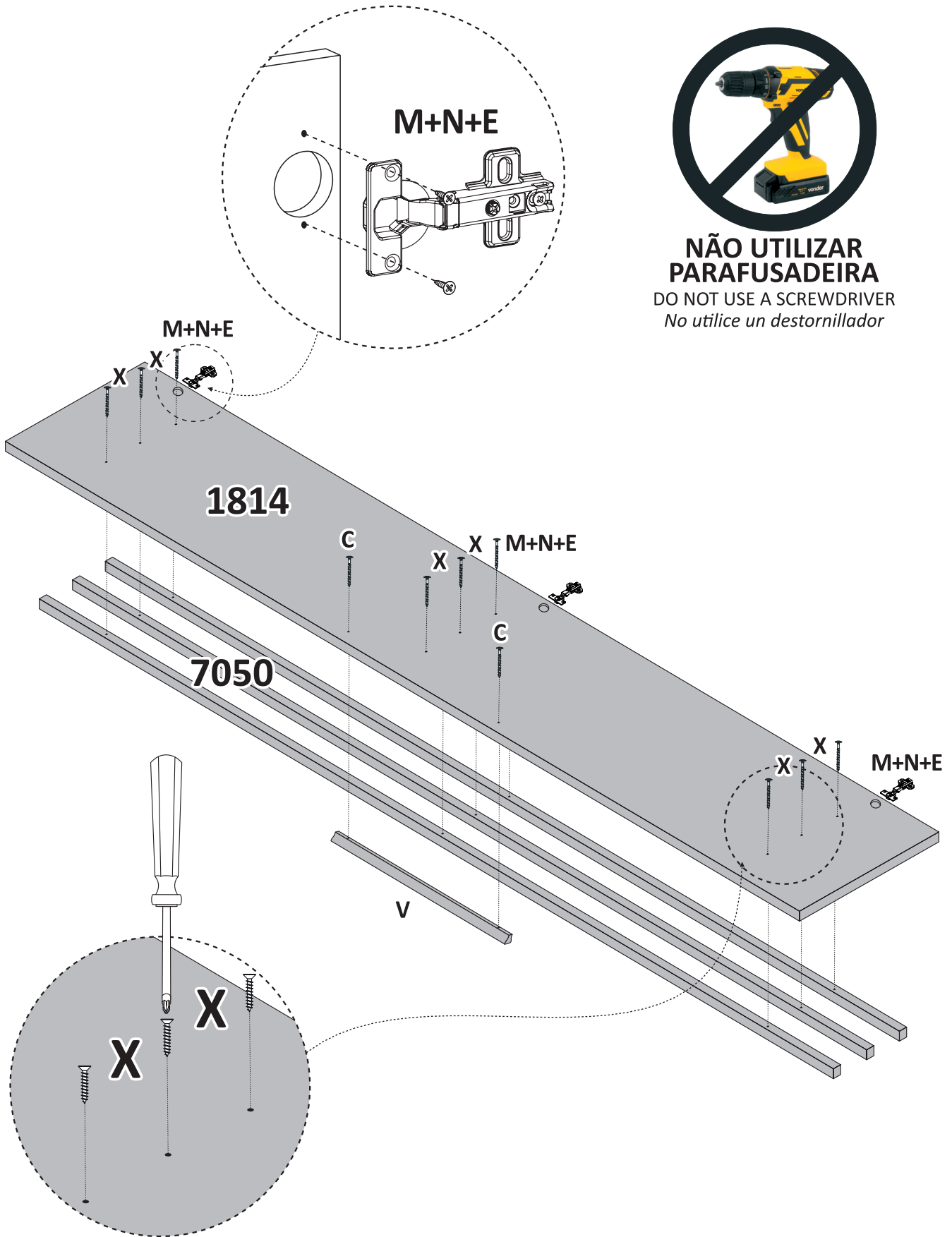

Coloção das Portas.

Door Placement.

Colocación de Puertas.

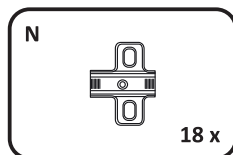
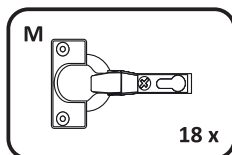
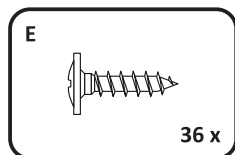
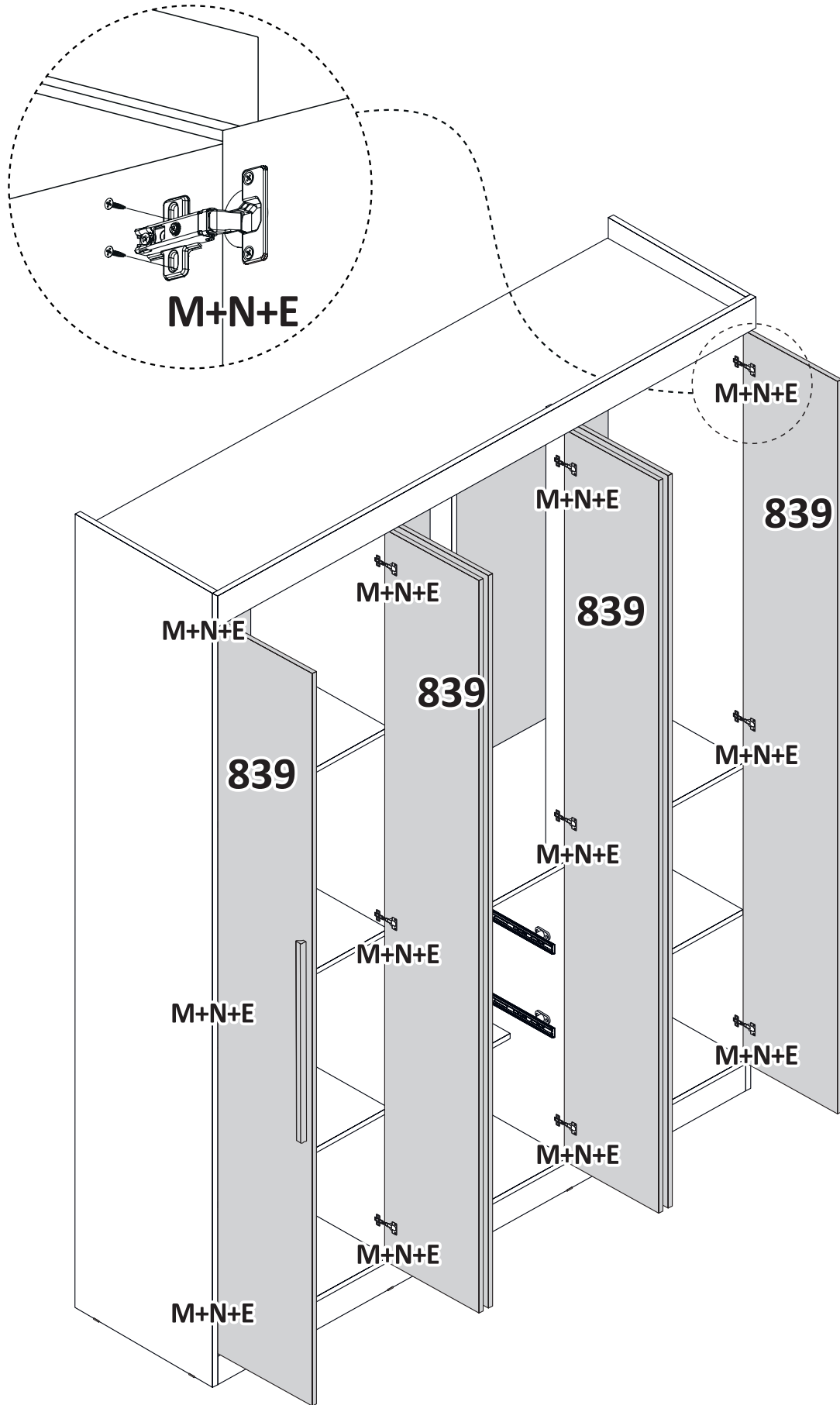

Montagem das Gavetas.

Assembling the Drawers.
Montaje de Cajones.

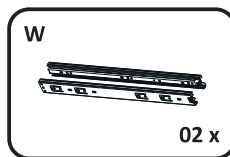
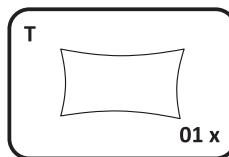
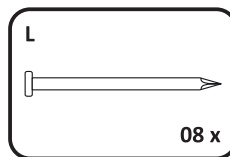
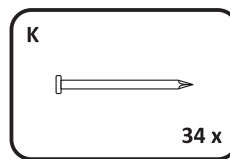
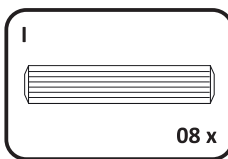
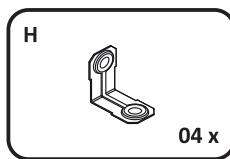
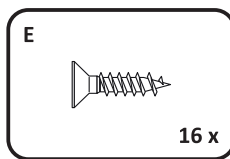
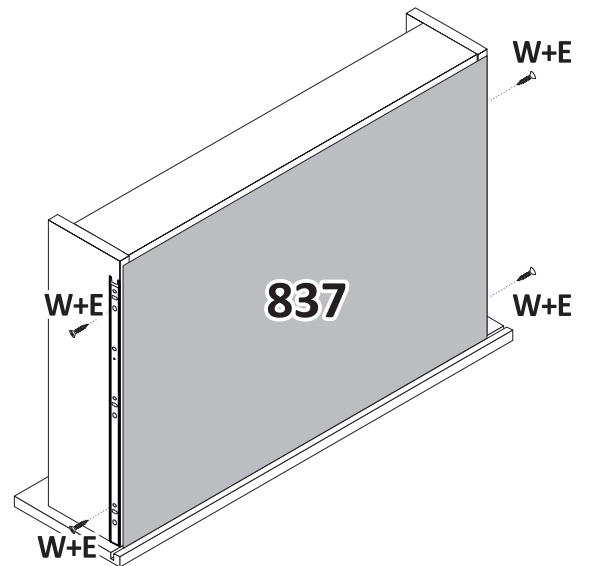
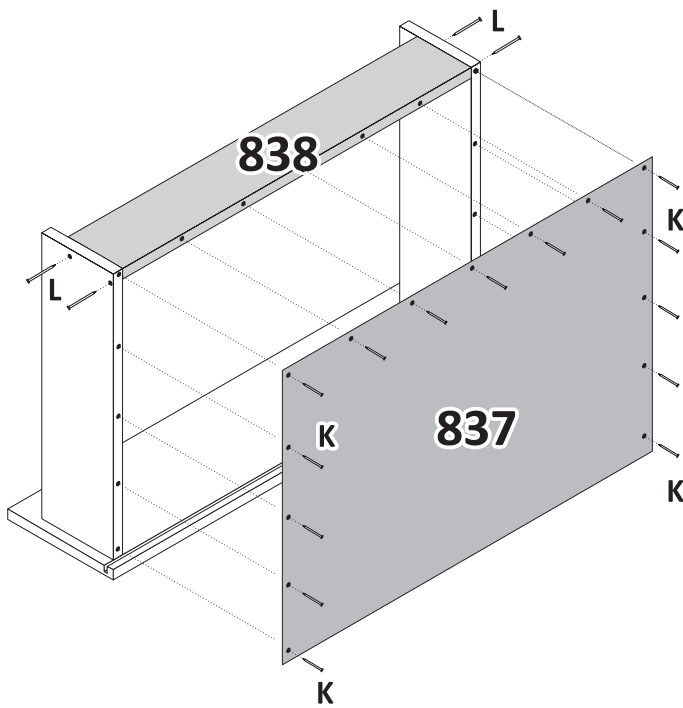
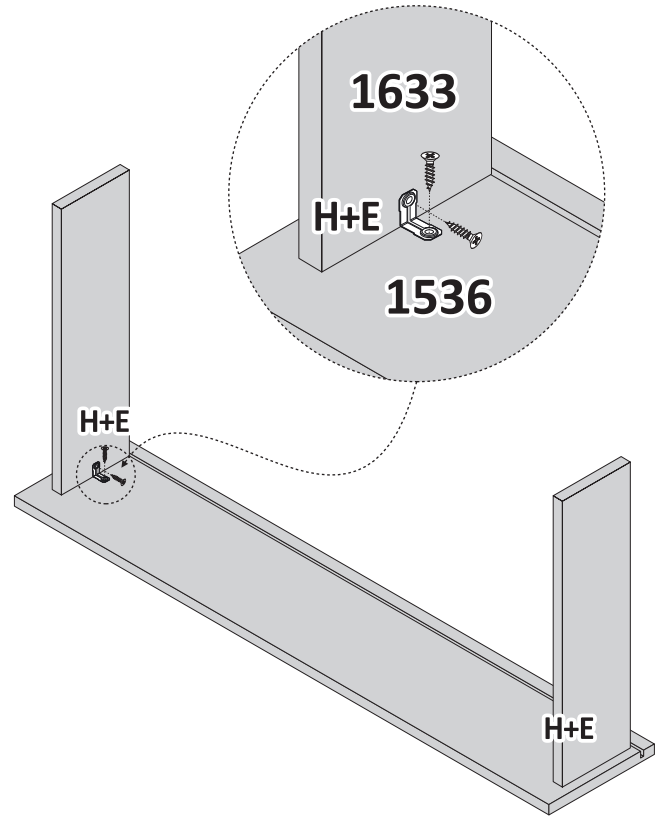
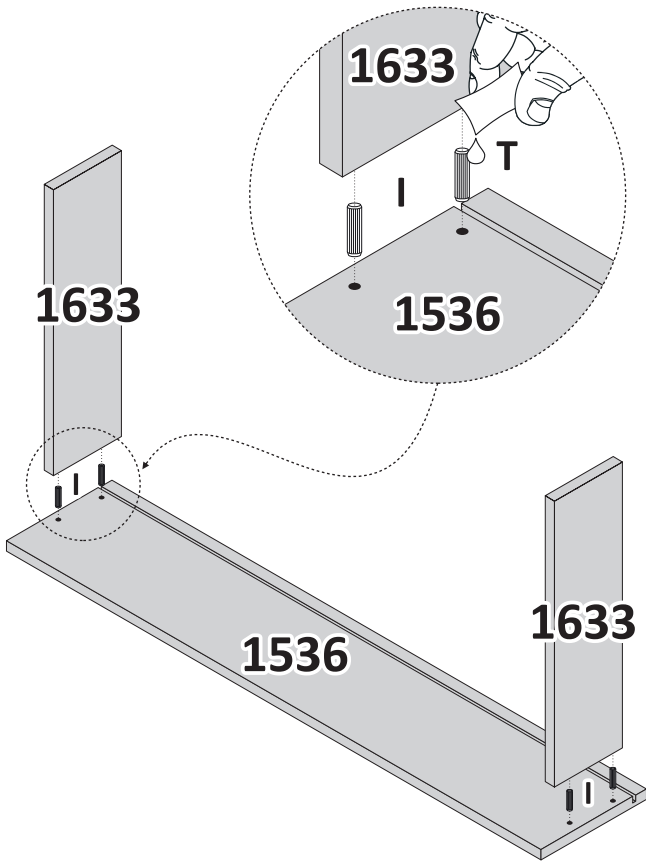

Produto montado.

Asembled product.
Producto ensamblado.

32 98887667
M

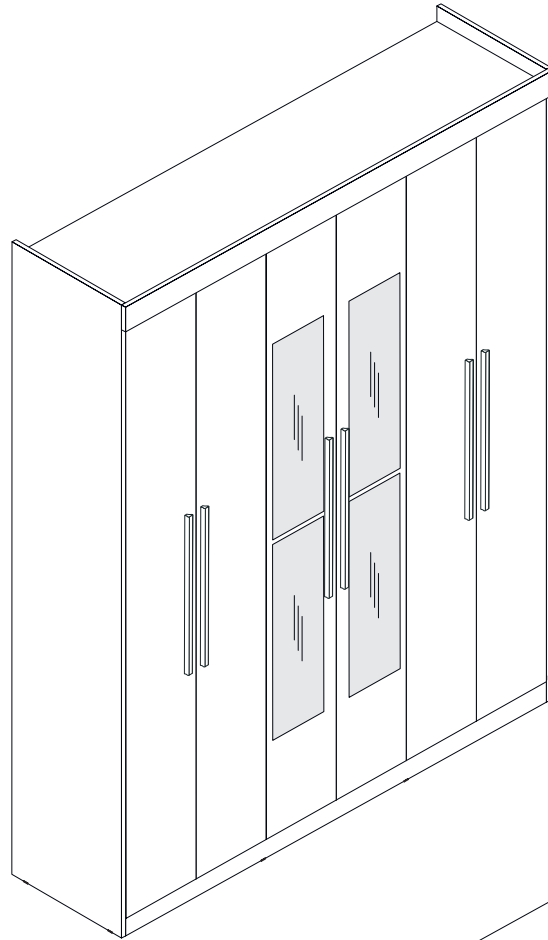

RP 68600

ESPELHO OPCIONAL
OPTIONAL MIRROR
ESPEJO OPCIONAL

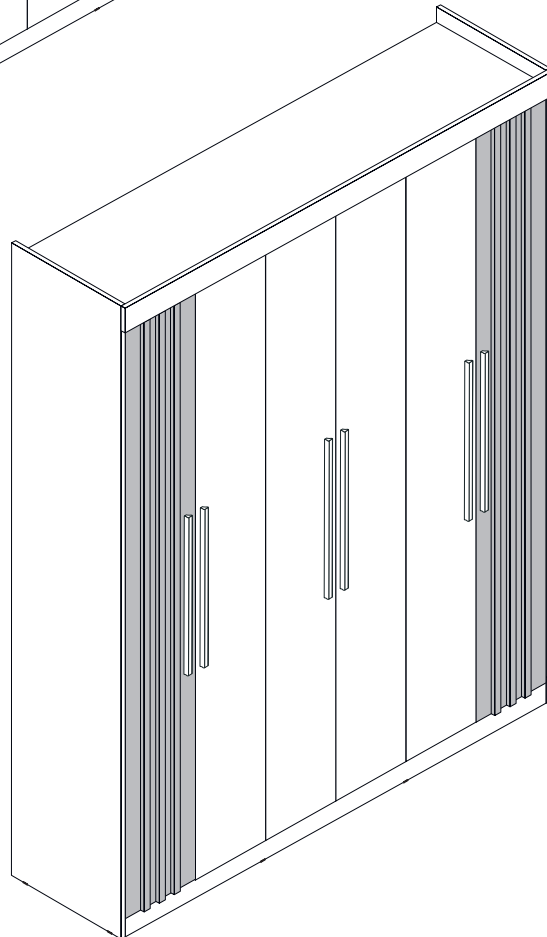

RP 40650

PORTA RIPADA
SLATTED DOOR
PUERTA RANURADA

Doripel
móveis

Moveis.Doripel

DoripelMoveis

54 3358.6500

Av. Julio Vanzin, 1600 - Área Industrial Lagoa Vermelha - RS - Brasil

comercial@doripel.com.br | assistencia@doripel.com.br

doripel.com.br