

Doripel

móveis

MANUAL DE MONTAGEM
ASSEMBLE INSTRUCTONS
INSTRUCCIONES DE ARMADO

CM 20268

Cômoda 8 Gavetas

Acesse a Instrução de montagem completa pelo QRCode.

Access the complete assembly instructions via QRCode.

Accede las instrucciones de montaje completas mediante QRCode.

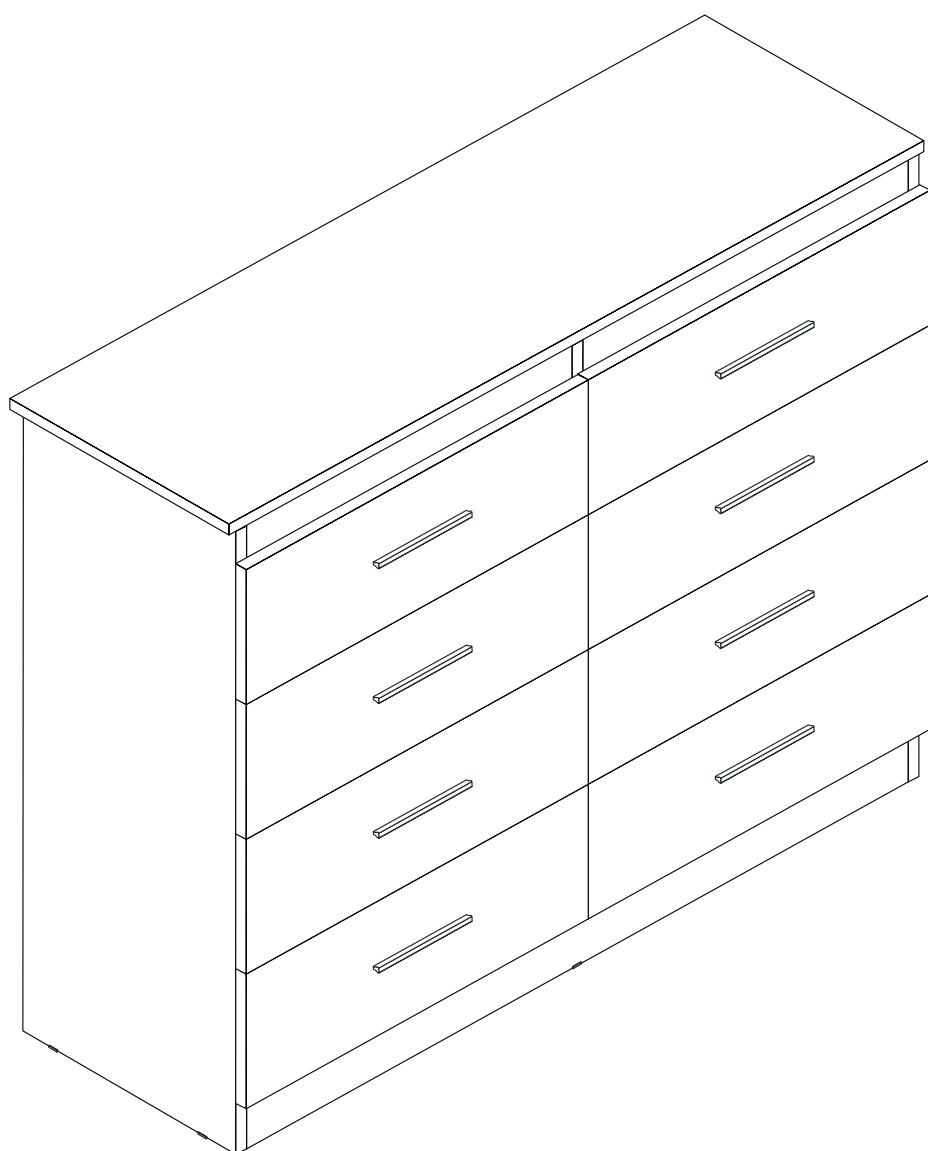
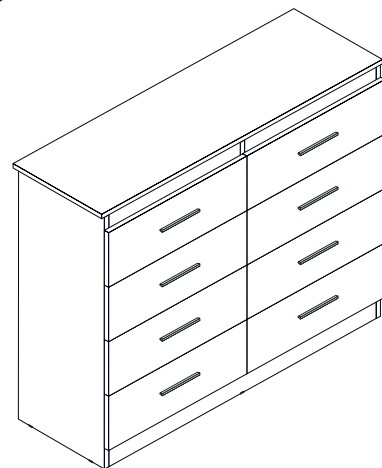

INSTRUÇÕES DE MONTAGEM DO ROUPEIRO

- 1- Começa preparando o espaço onde vai ser montado o roupeiro. Forre o chão para que não arranhe o móvel.
 - 2- Ter as ferramentas necessárias como: parafusadeira, chave de fenda, etc.
 - 3- Abrir as caixas e conferir as peças conforme está no manual.
 - 4-Fazer a separação das peças como indicado na imagem.
 - 5-Começa pela base pelas partes menores seguindo as etapas descritas no manual.
 - 6- Montar o roupeiro deitado com a frente para baixo para facilitar o trabalho.
 - 7-As portas e gavetas serão instaladas por último.
 - 8-E por fim verifique se está tudo certo alinhado e fixado corretamente.
- Lembrando que o esquema de montagem varia entre os modelos de roupeiros.
 - É aconselhável pedir ajuda a outra pessoa para te auxiliar na hora de erguer o móvel.

WARDROBE ASSEMBLY INSTRUCTIONS

- 1- Start by preparing the space where the wardrobe will be assembled. Cover the floor so that it does not scratch the furniture.
 - 2- Have the necessary tools such as: screwdriver, screwdriver, etc.
 - 3- Open the boxes and check the parts as shown in the manual.
 - 4- Separate the parts as shown in the image.
 - 5- Start at the base with the smallest parts following the steps described in the manual.
 - 6- Assemble the wardrobe lying face down to make the work easier.
 - 7- The doors and drawers will be installed last.
 - 8- And finally check that everything is aligned and correctly fixed.
- Remember that the assembly scheme varies between wardrobe models.
 - It is advisable to ask another person to help you when lifting the furniture.







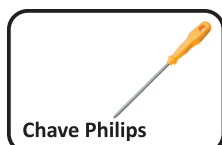

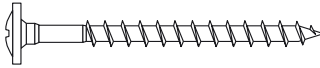
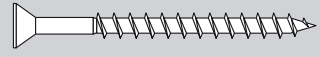
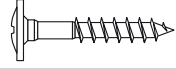

INSTRUCCIONES DE MONTAJE DEL ARMARIO

- 1- Prepare el espacio donde se montará el armario. Cubra el suelo para que no raye el mueble.
 - 2- Disponga de las herramientas necesarias, como destornillador, destornillador, etc.
 - 3- Abra las cajas y revise las piezas como se indica en el manual.
 - 4- Separe las piezas como se muestra en la imagen.
 - 5- Comience por la base con las piezas más pequeñas siguiendo los pasos descritos en el manual.
 - 6- Monte el armario boca abajo para facilitar el trabajo.
 - 7- Las puertas y los cajones se instalarán en último lugar.
 - 8- Por último, compruebe que todo esté alineado y correctamente fijado.
- Recuerde que el esquema de montaje varía según el modelo de armario.
 - Se recomienda pedir ayuda a otra persona para levantar el mueble.

MATERIAL PARA MONTAGEM | ASSEMBLY MATERIAL | MATERIAL PARA ARMADO

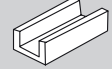

FERRAGEM | HARDWARE | HERRAJES

A	PARAFUSO FLANGEADO 3,5x40 FLANGE SCREW 3,5x40 TORNILLO FLANGEADO 3,5x40		14
B	PARAFUSO C/C 3,5x40 SCREW 3,5x40 TORNILLO 3,5x40		03
C	PARAFUSO FLANGEADO 3,5x25 FLANGE SCREW 3,5x25 TORNILLO FLANGEADO 3,5x25		16
D	PARAFUSO 3,5x12 SCREW 3,5x12 TORNILLO 3,5x12		128
E	CANTONEIRA 18x18 18x18 CORNER ESQUINA 18x18		28
F	CAVILHA 6x30 6x30 PEGS TACOS 6x30		42
G	CAVILHA 6x50 6x50 PEGS TACOS 6x50		01
H	PREGO 10x10 C/C NAIL 10x10 CLAVO 10x10		229
I	PREGO 13x15 C/C NAIL 13x15 CLAVO 13x15		32
J	SAPATA SHOE ZAPATA		06
K	COLA GLUES PEGAMENTO		01
L	PUXADOR HANDLE TIRADOR		08
M	CORREDIÇA SLIDER CORREDIZA		08



UTILIZE A RÉGUA PARA A MEDIÇÃO DOS PARAFUSOS | USE THE RULER TO MEASURE THE SCREWS | USA LA REGLA PARA MEDIR LOS TORNILLOS

LISTA DE PEÇAS | PARTS LIST | LISTA DE PIEZAS

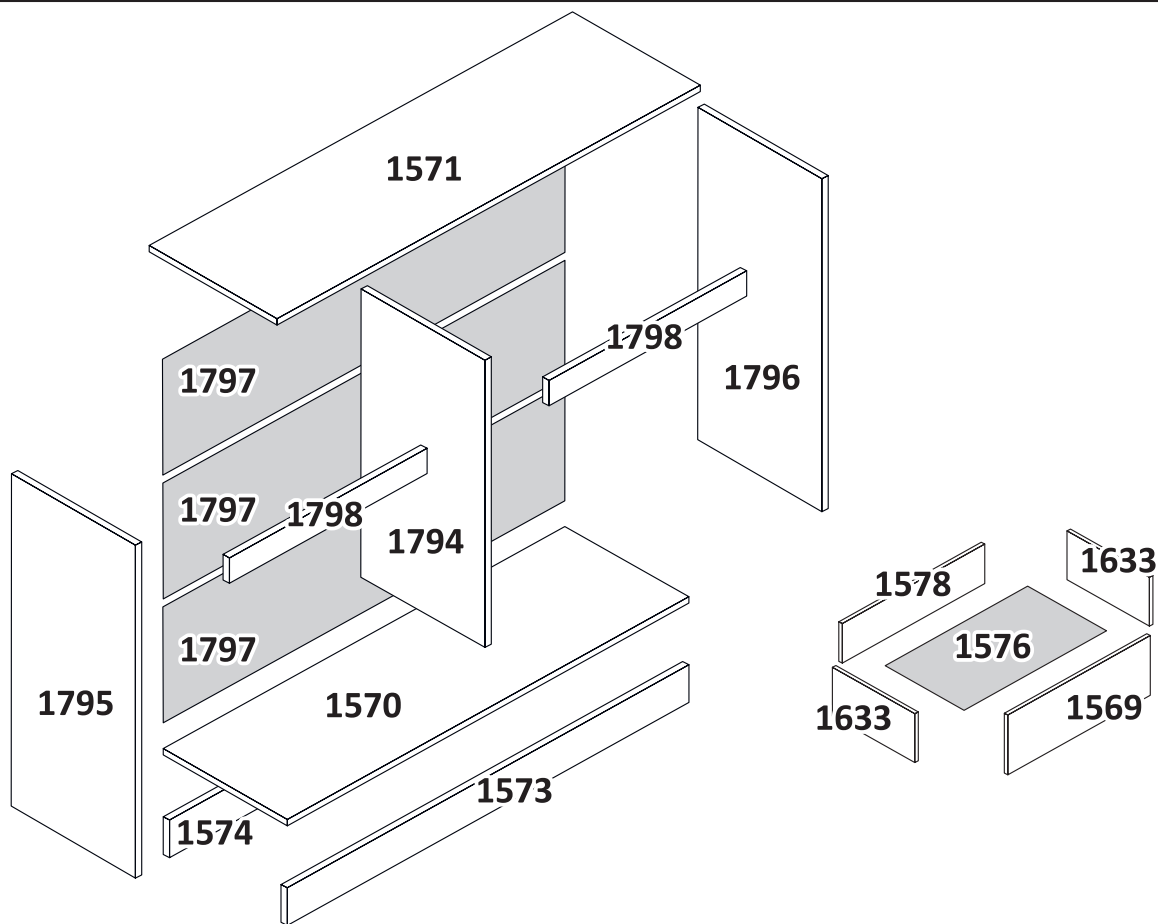

CÓDIGO CODE CODIGO	DESCRIÇÃO DESCRIPTION DESCRIPCIÓN	QTD. QUANTITY CANTIDAD	DIMENSÕES		DIMENSIONS		DIMENSIONES
			COMP. LENGTH LONGITUD	LARG. WIDTH ANCHO	CHAPA PLATE LÁMINA		
1578	TRASEIRO GAVETA DRAWER BACK / TRASERA DEL CAJÓN	08	0,526	0,070			12mm
1633	LATERAL GAVETA DRAWER SIDE / LATERAL DEL CAJÓN	16	0,320	0,085			12mm
1576	FUNDO GAVETA DRAWER BOTTOM / FONDO DEL CAJÓN	08	0,548	0,327			3mm
1571	TAMPO SUPERIOR TOP PANEL / TAPA SUPERIOR	01	1,210	0,384			15mm
1797	COSTAS BACK PANEL / PARTE TRASERA	03	1,180	0,305			3mm
1794	DIVISÃO DIVIDER / DIVISIÓN	01	0,893	0,360			12mm
1795	LATERAL ESQUERDA LEFT SIDE / LATERAL IZQUIERDA	01	1,010	0,360			12mm
1569	FRENTE GAVETA DRAWER FRONT / FRENTE DEL CAJÓN	08	0,582	0,210			12mm
1798	APLIQUE APPLIQUÉ / APLIQUE	02	0,575	0,085			15mm
1796	LATERAL DIREITA RIGHT SIDE / LATERAL DERECHA	01	1,010	0,360			12mm
1573	RODAPÉ FRONTAL FRONT SKIRT / RODAPIÉ FRONTAL	01	1,162	0,105			15mm
1574	RODAPÉ TRASEIRO REAR SKIRT / RODAPIÉ TRASERO	01	1,162	0,105			15mm
1570	TAMPO INFERIOR BOTTOM PANEL / TAPA INFERIOR	01	1,162	0,360			12mm

Preparando a Lateral Direita.

Preparing Right Side.

Preparante Lateral Derecha.

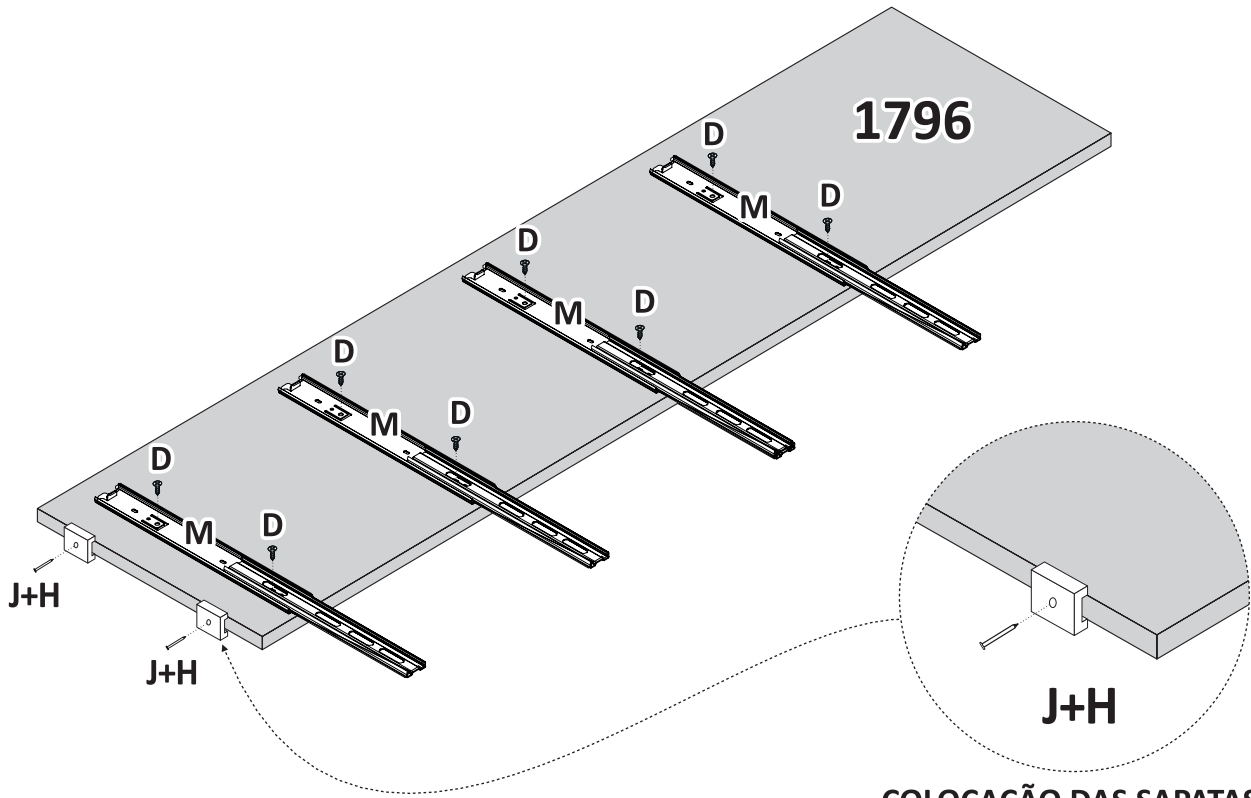

COLOCAÇÃO DAS SAPATAS.

putting on the shoes.
poniéndose los zapatos.

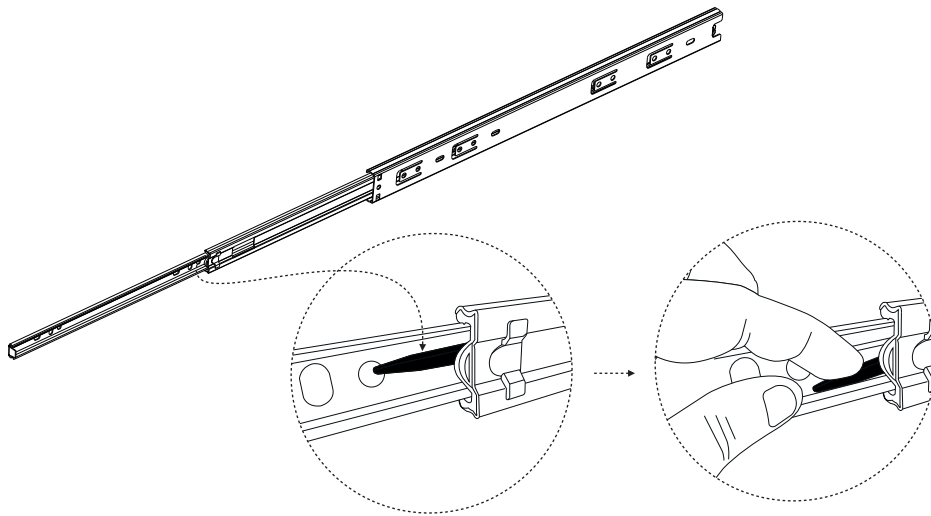

ABAIXE A TRAVA PRETA E RETIRE A PEÇA CONFORME DESENHO ABAIXO.

LOWER THE BLACK LATCH AND REMOVE THE PART AS SHOWN IN THE DRAWING BELOW.
BAJE EL SEGURO NEGRO Y RETIRE LA PIEZA SEGÚN EL DIBUJO DE ABAJO.

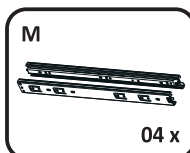
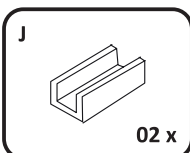
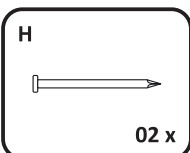
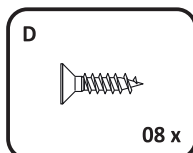
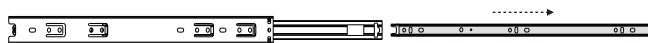

Preparando a Divisão.

Preparing Divider.
Preparante División.

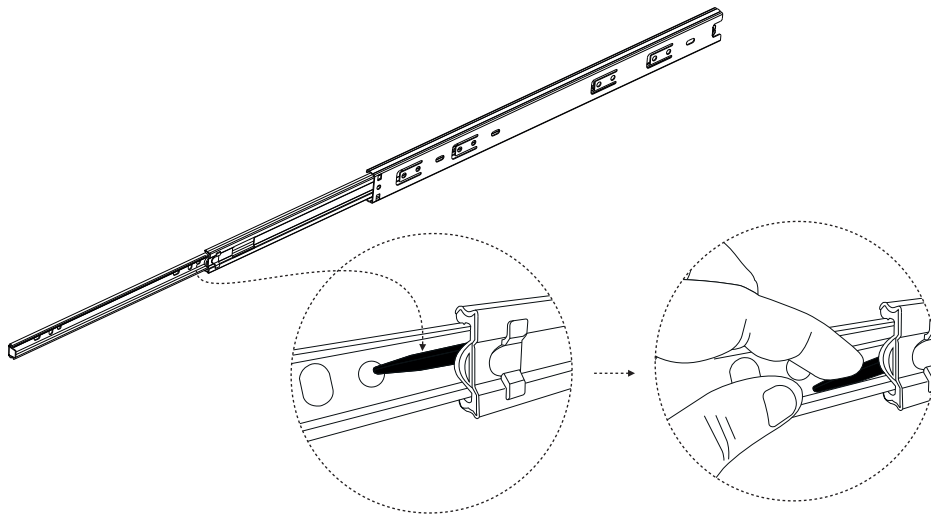
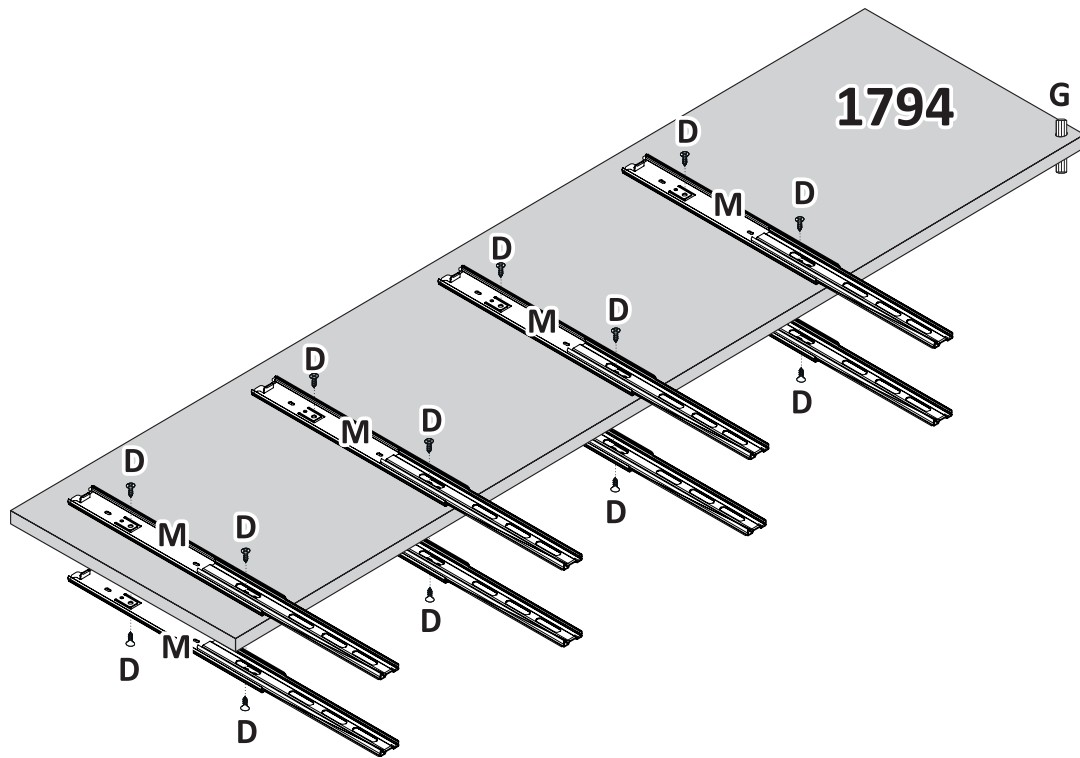

ABAIXE A TRAVA PRETA E RETIRE A PEÇA CONFORME DESENHO ABAIXO.
LOWER THE BLACK LATCH AND REMOVE THE PART AS SHOWN IN THE DRAWING BELOW.
BAJE EL SEGURO NEGRO Y RETIRE LA PIEZA SEGÚN EL DIBUJO DE ABAJO.

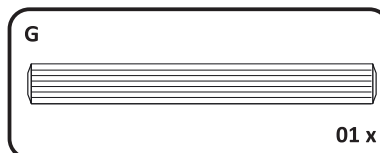
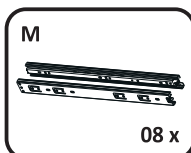
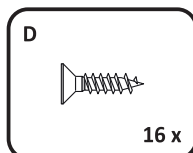
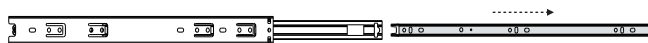

Montar as Divisões.

Assembly Divider.
Montaje División.

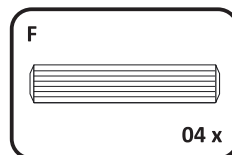
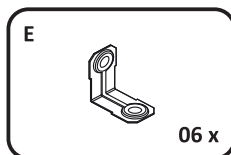
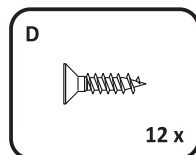
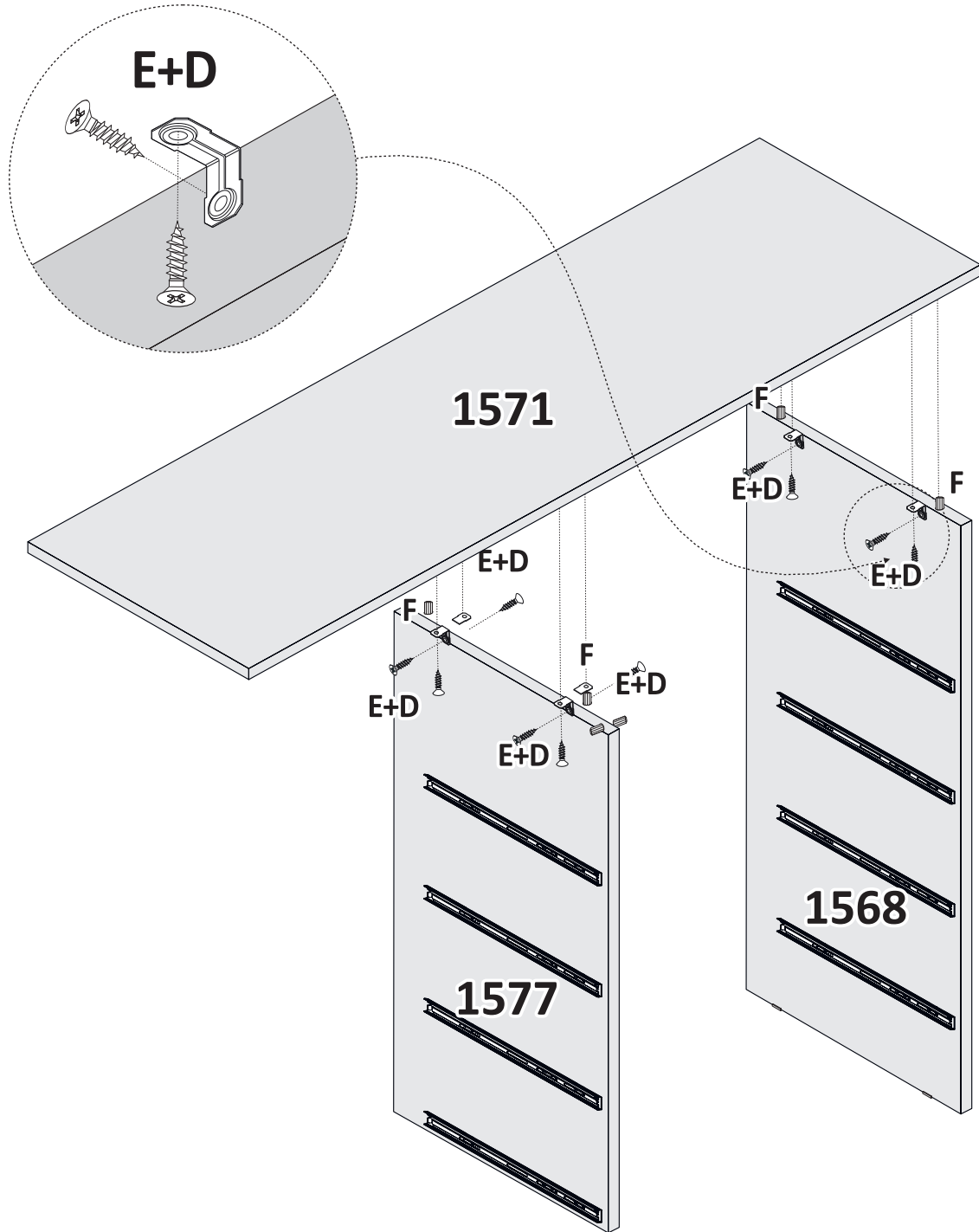

Preparando Aplique.

Preparing Applique.
Preparante Aplique.

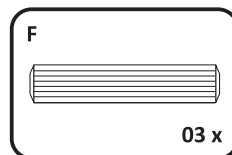
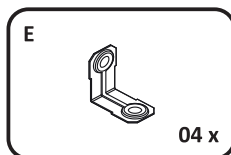
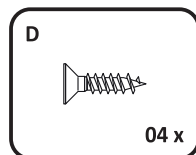
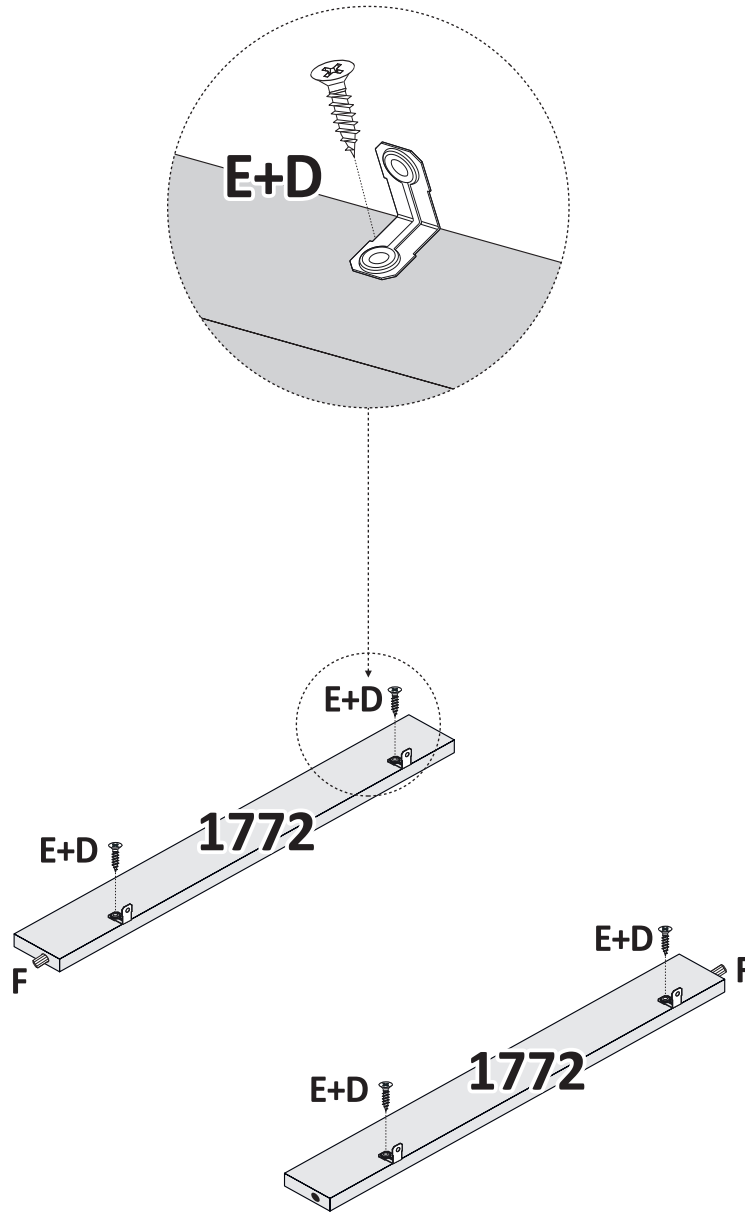

Montar Aplique.

Assembly Applique.
Montaje Aplique.

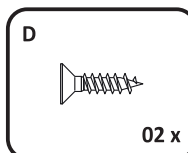
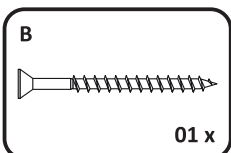
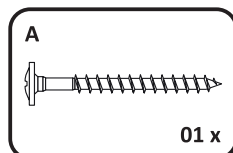
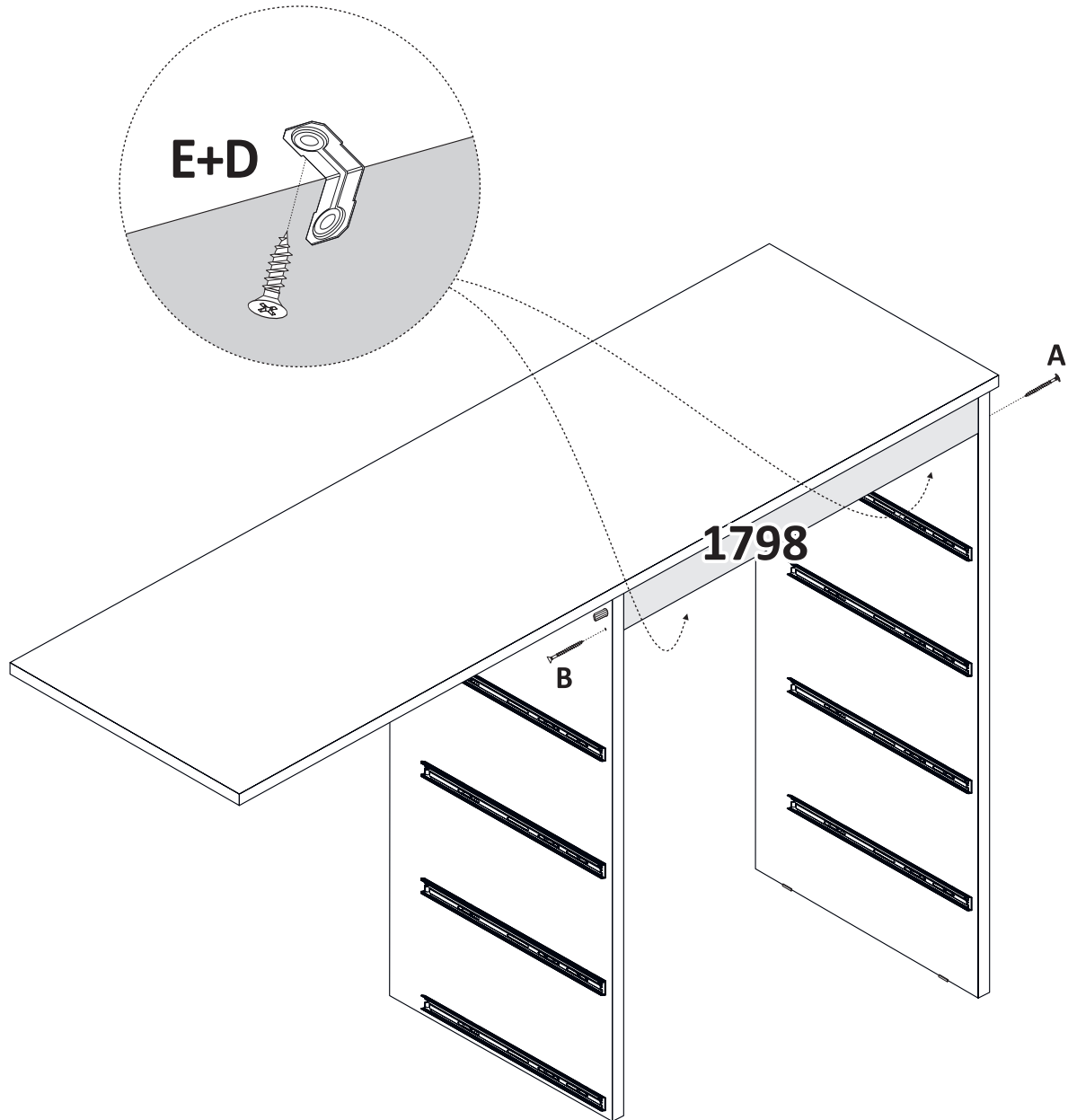

Preparando a Lateral Esquerda.

Preparing Left Side.

Preparante Lateral Izquierda.

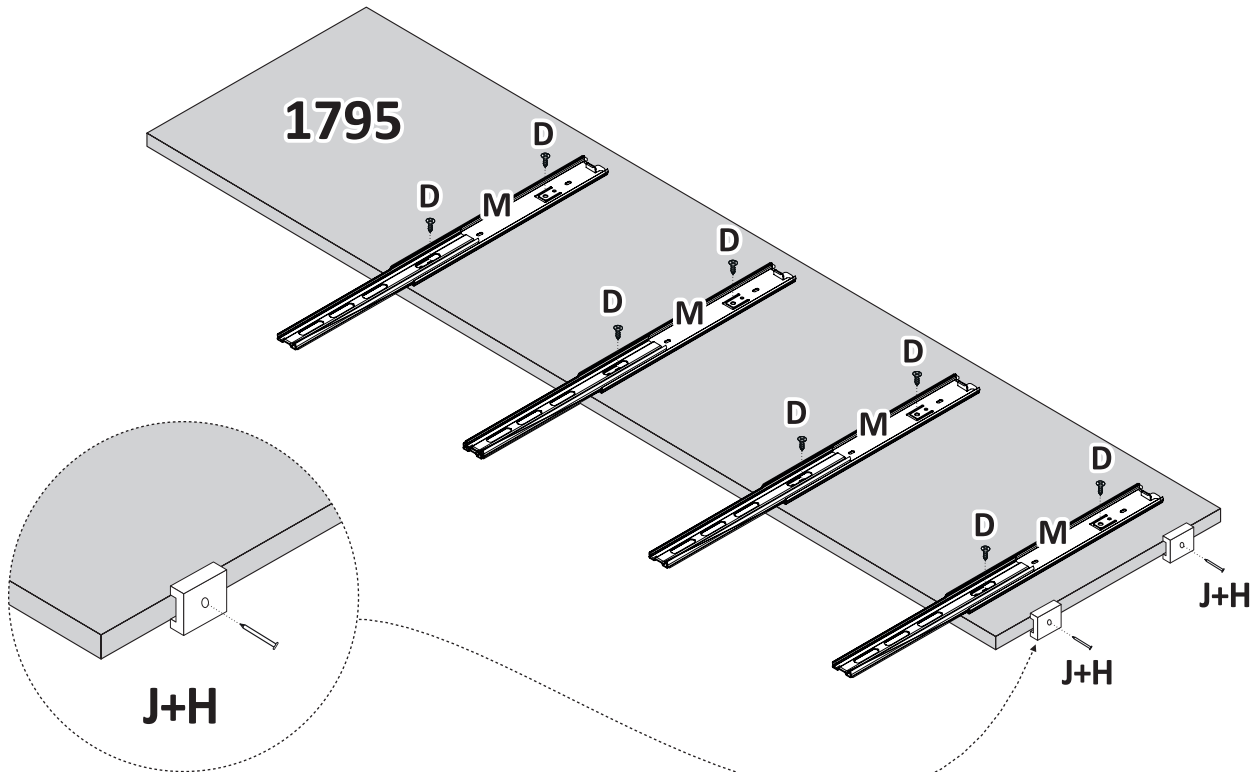

COLOCAÇÃO DAS SAPATAS.

putting on the shoes.
poniéndose los zapatos.

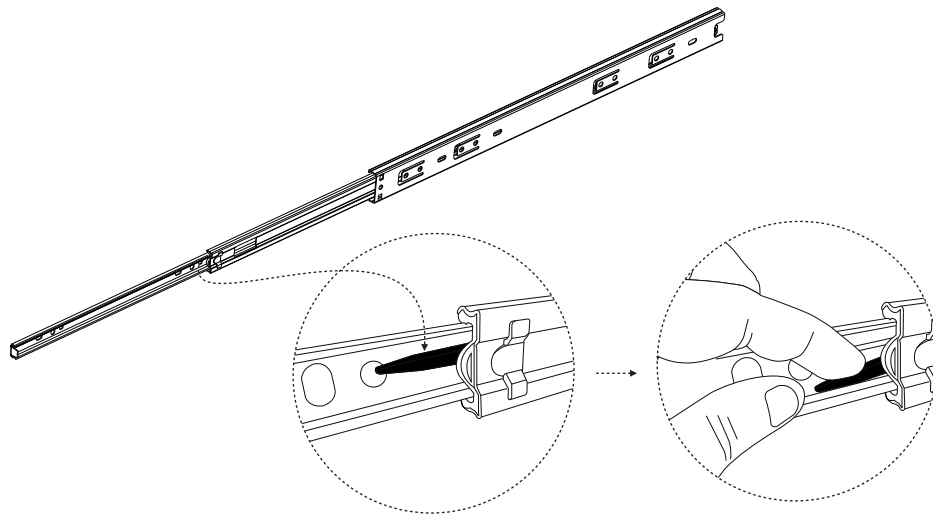

ABAIXE A TRAVA PRETA E RETIRE A PEÇA CONFORME DESENHO ABAIXO.

LOWER THE BLACK LATCH AND REMOVE THE PART AS SHOWN IN THE DRAWING BELOW.
BAJE EL SEGURO NEGRO Y RETIRE LA PIEZA SEGÚN EL DIBUJO DE ABAJO.

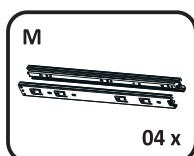
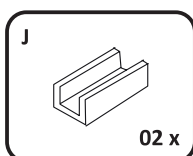
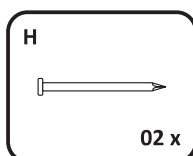
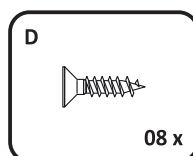
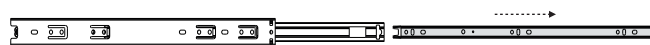

Preparando a Lateral Esquerda.

Preparing Left Side.

Preparante Lateral Izquierda.

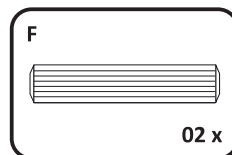
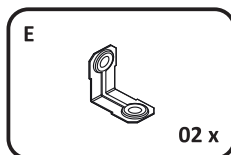
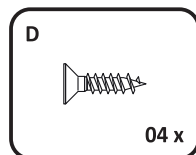
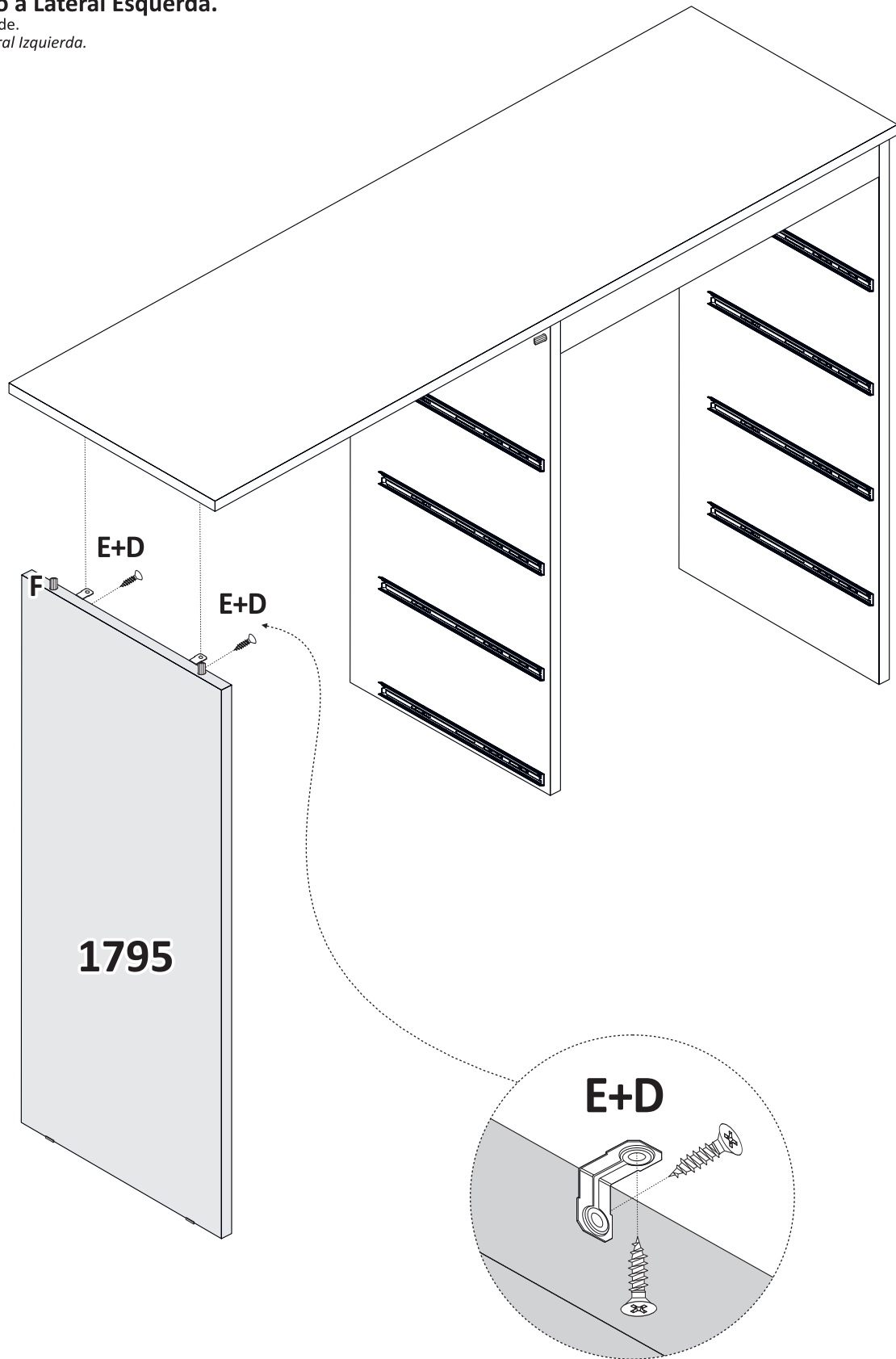

Montar Aplique.

Assembly Applique.

Montaje Aplique.

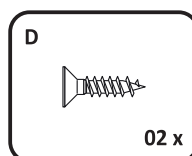
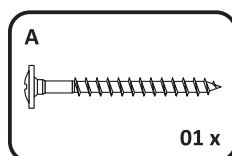
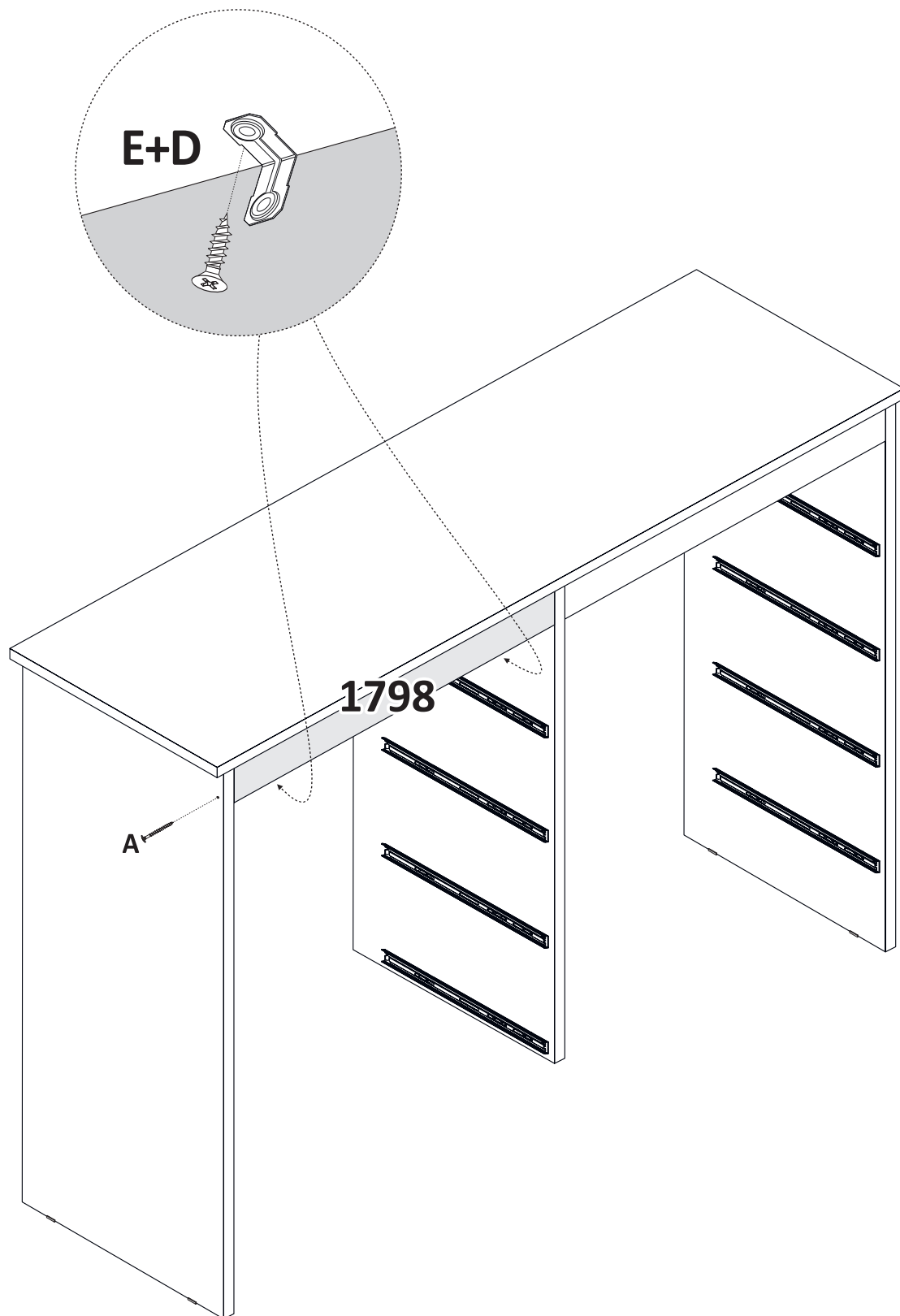

Montar Tampo Inferior.

Assembly Bottom Panel.

Montaje Tapa Inferior.

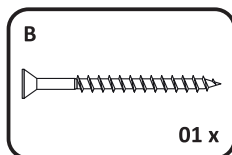
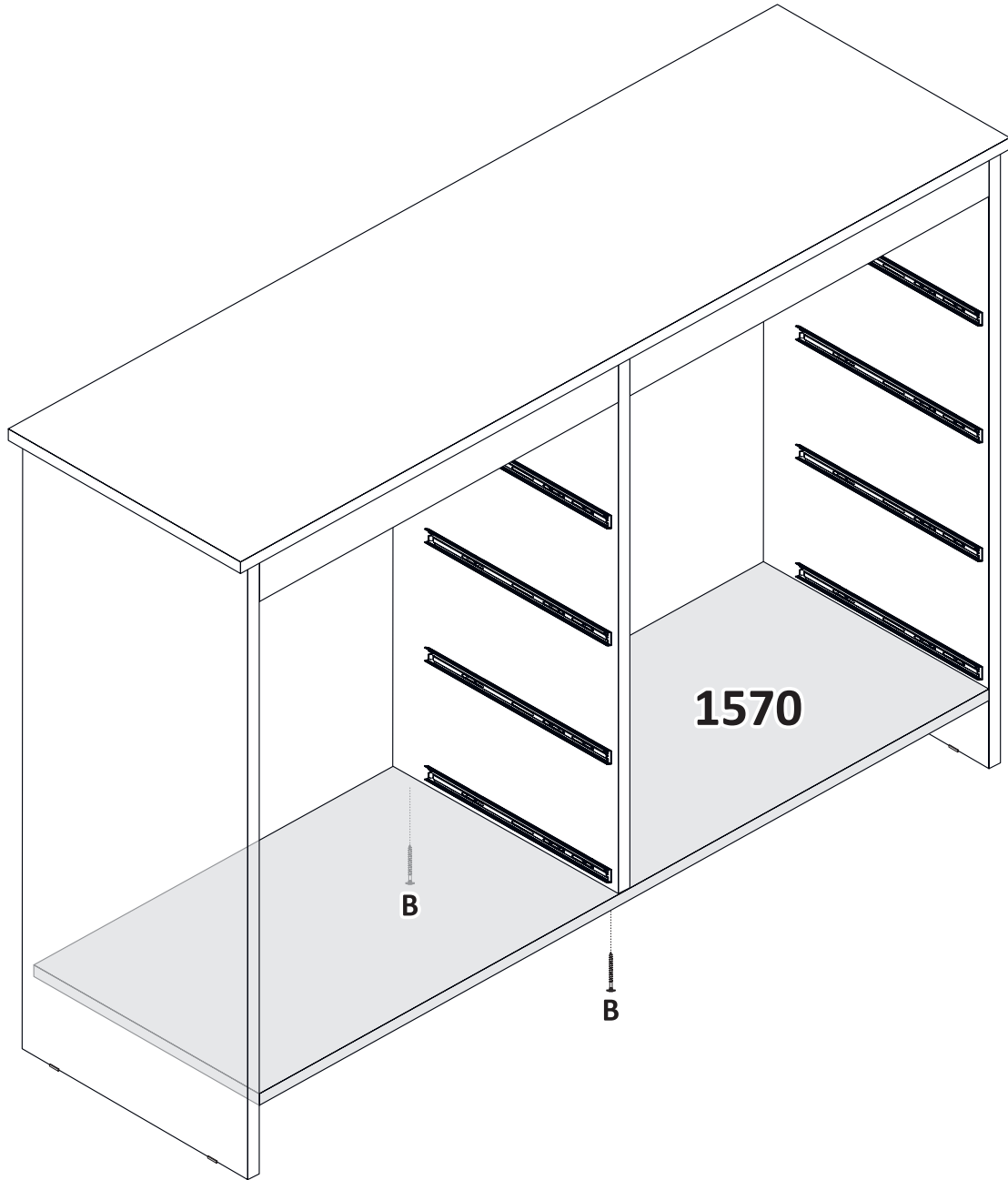

Preparando Rodapé.

Preparing Baseboard.

Preparante Zócalo.

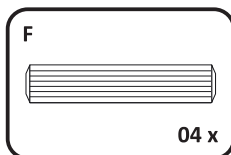
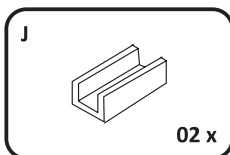
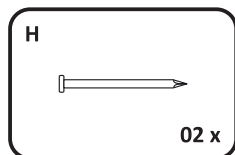
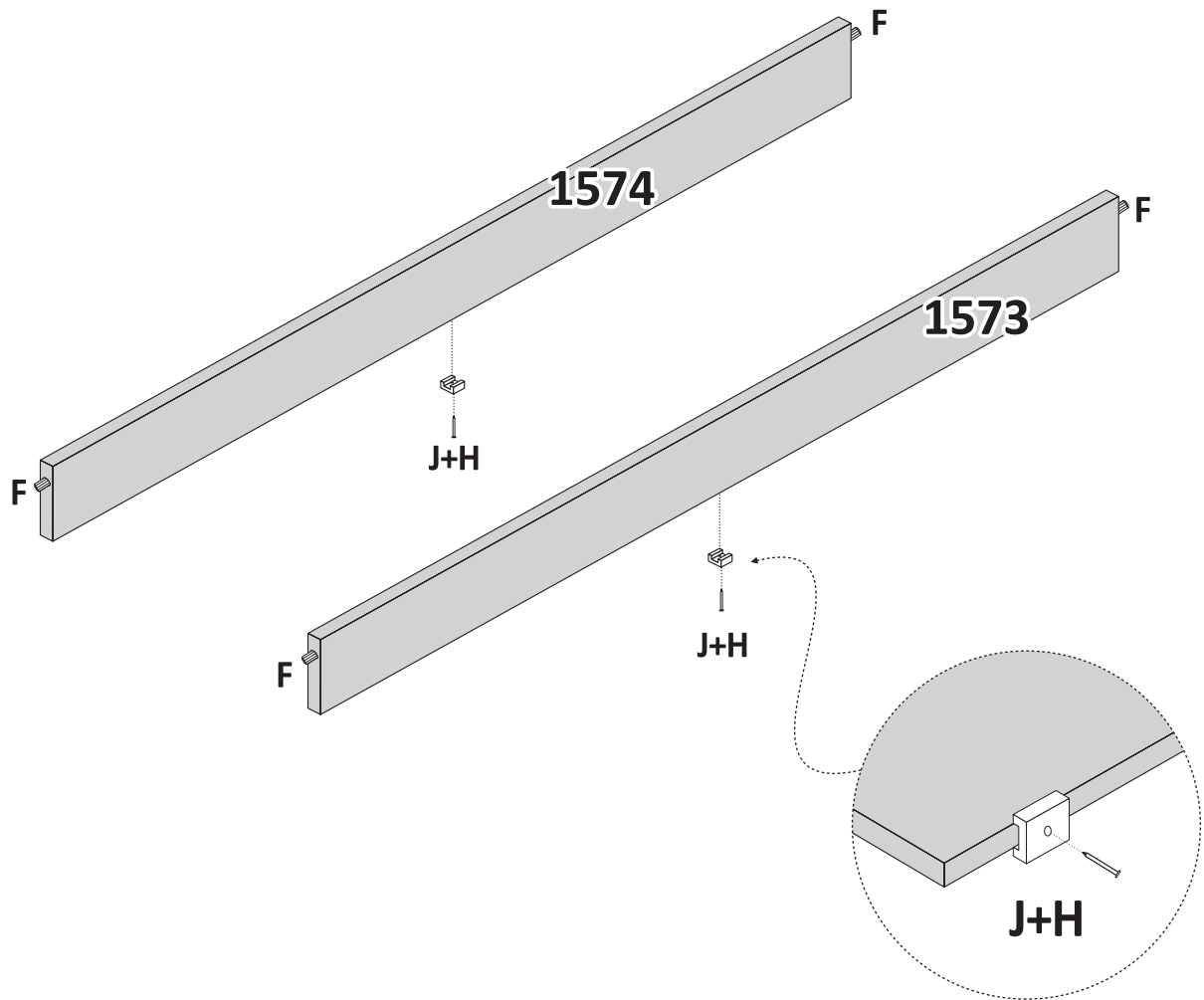

Montar Rodapé.

Assembly Baseboard.

Montaje Zócalo.

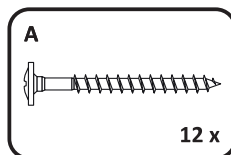
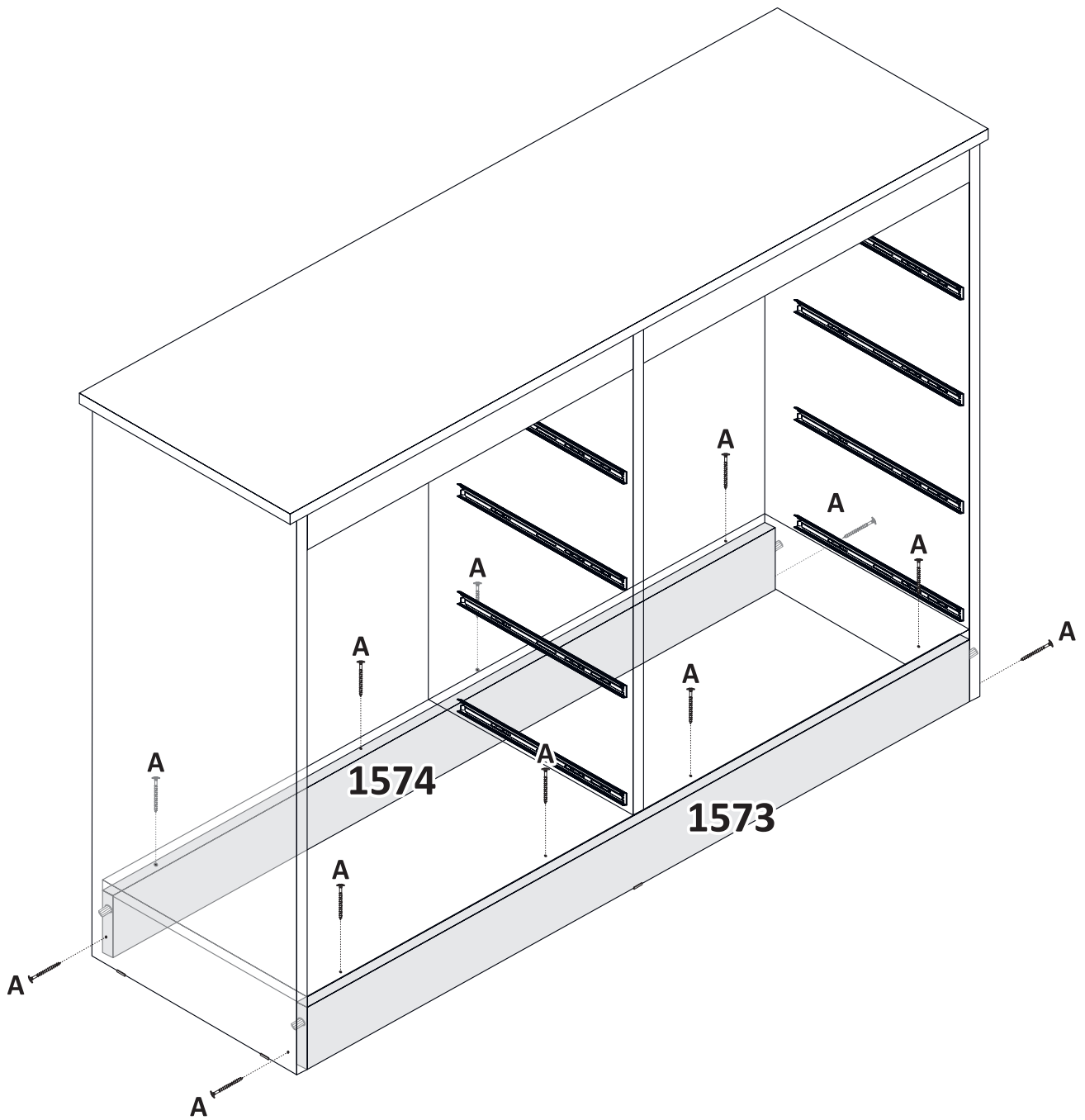

Montagem das Costas.

Back Assembly.
Montaje Trasero.

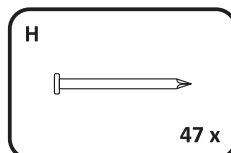
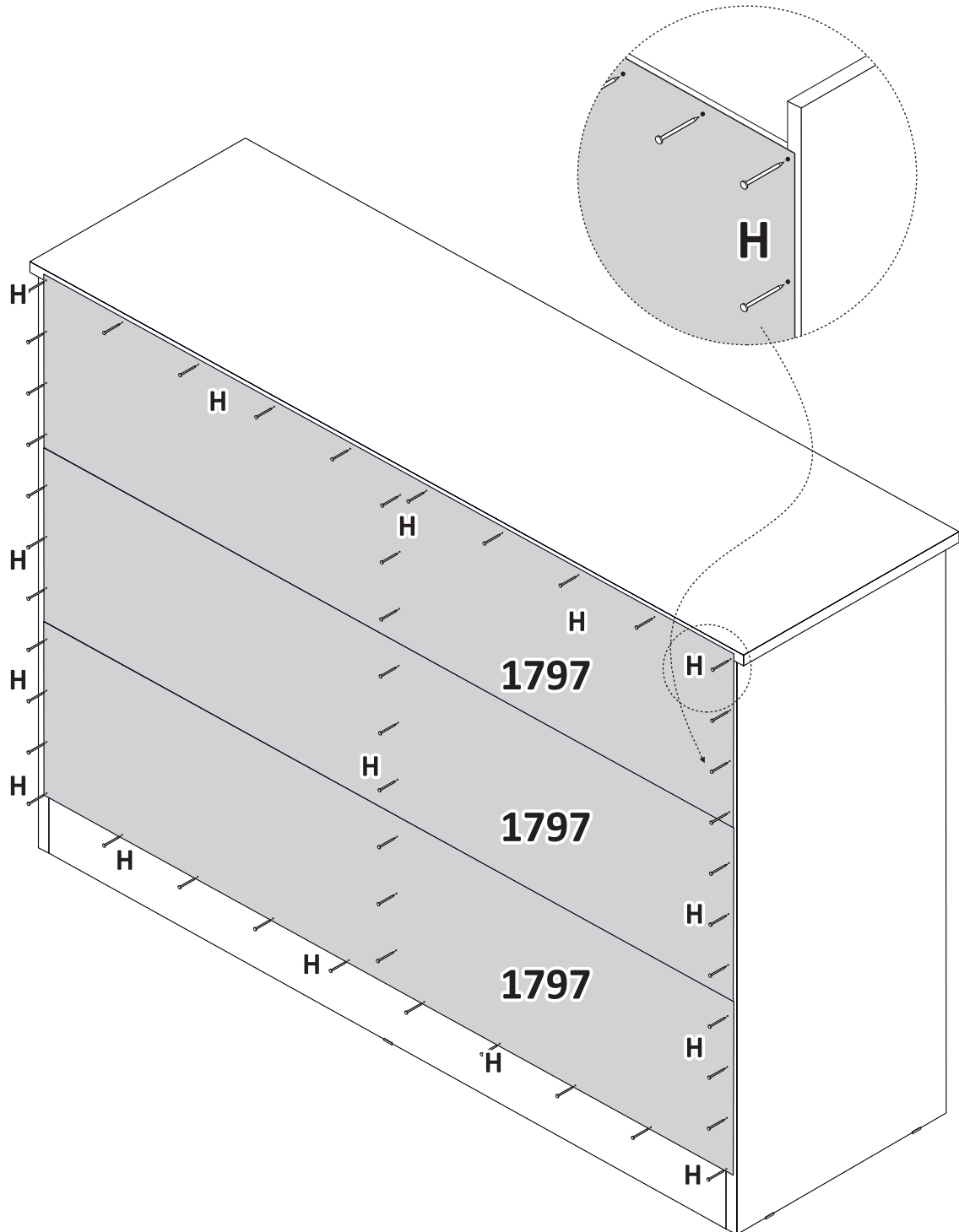

Peso suportado em cada parte.

Weight supported on each part.

Peso soportado en cada parte.

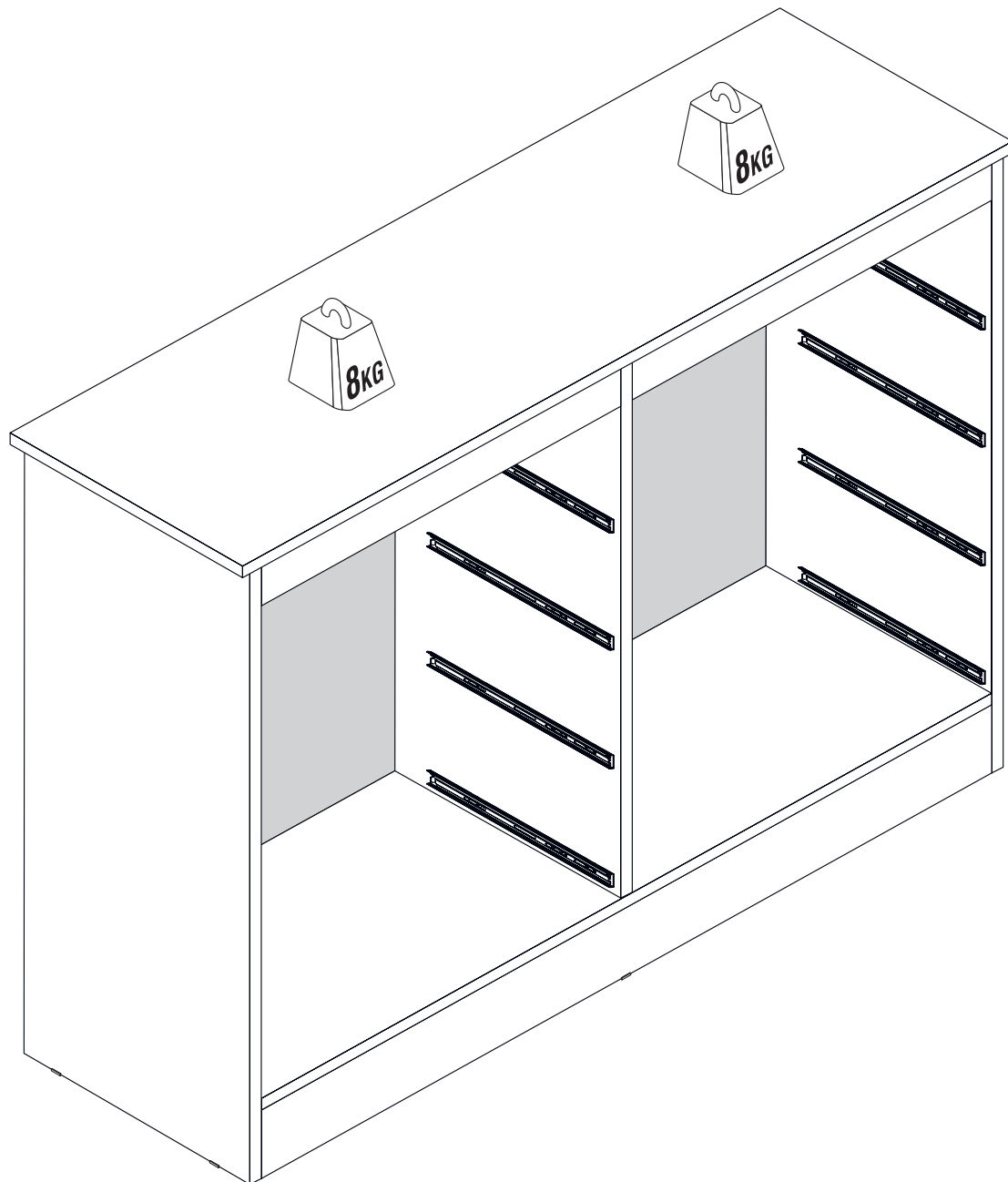

Medidas espaços internos.

Internal spaces measurements.

Medidas del espacios interiores.

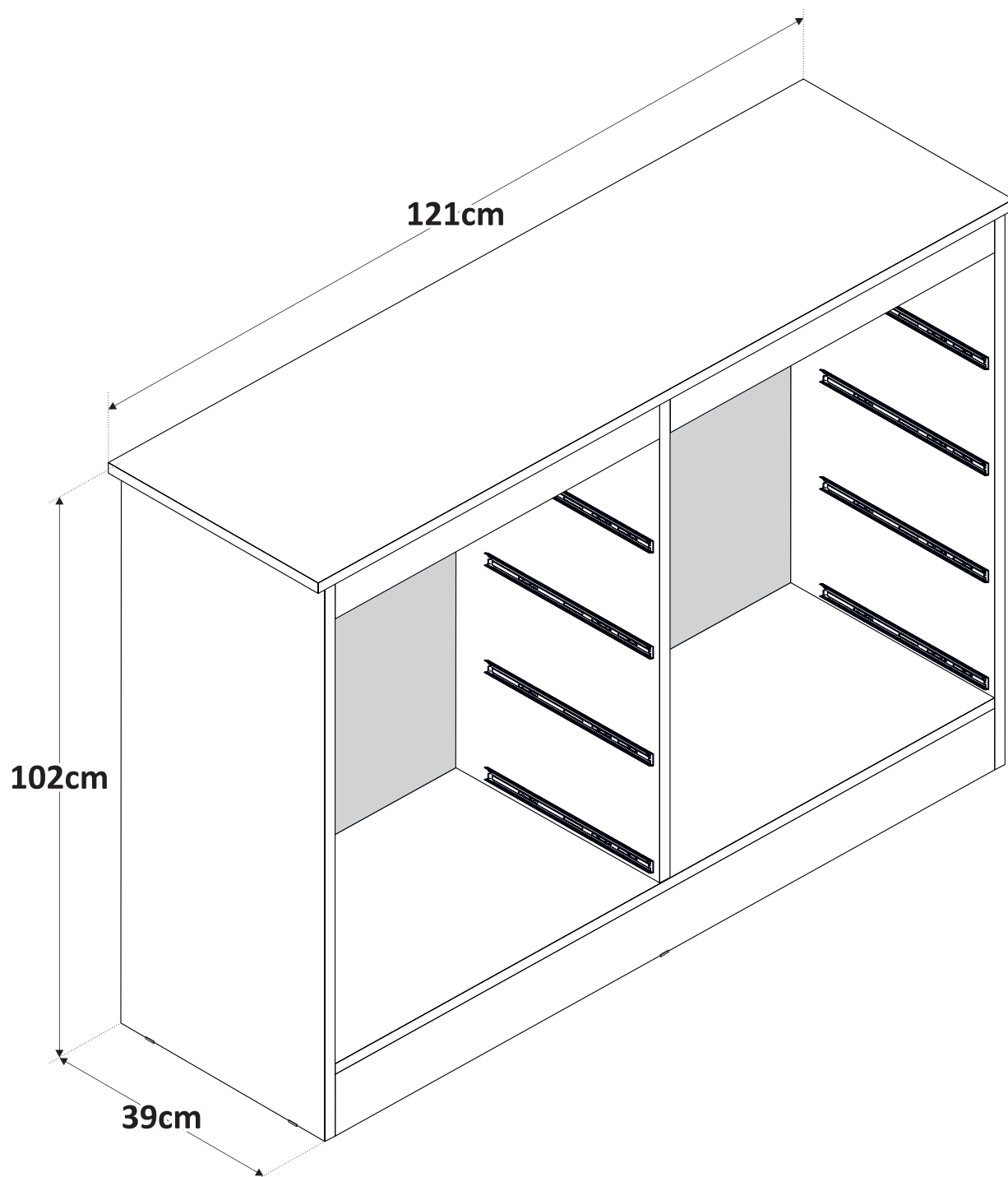

Montagem das Gavetas.

Assembling the Drawers.
Montaje de Cajones.

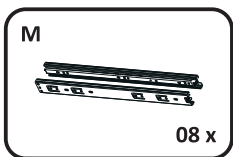
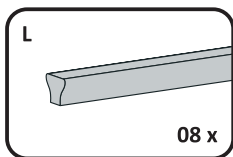
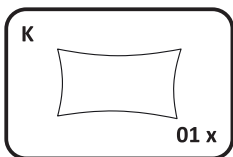
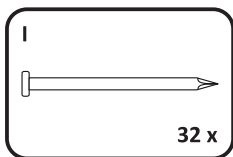
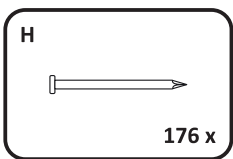
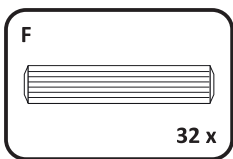
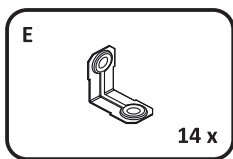
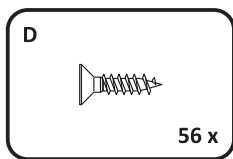
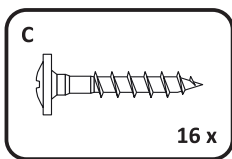
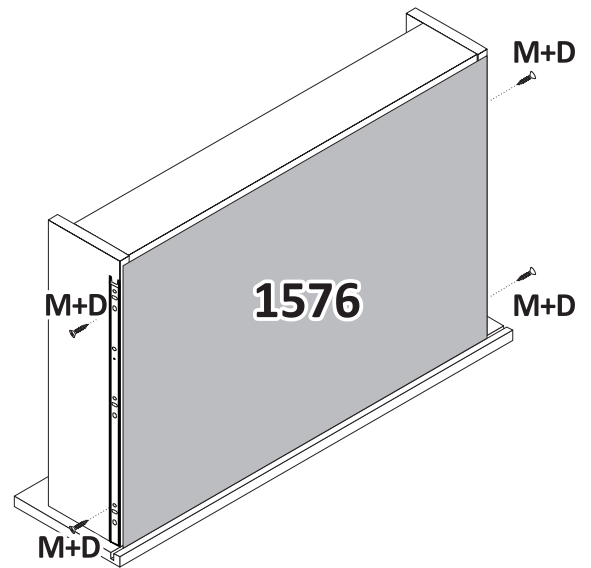
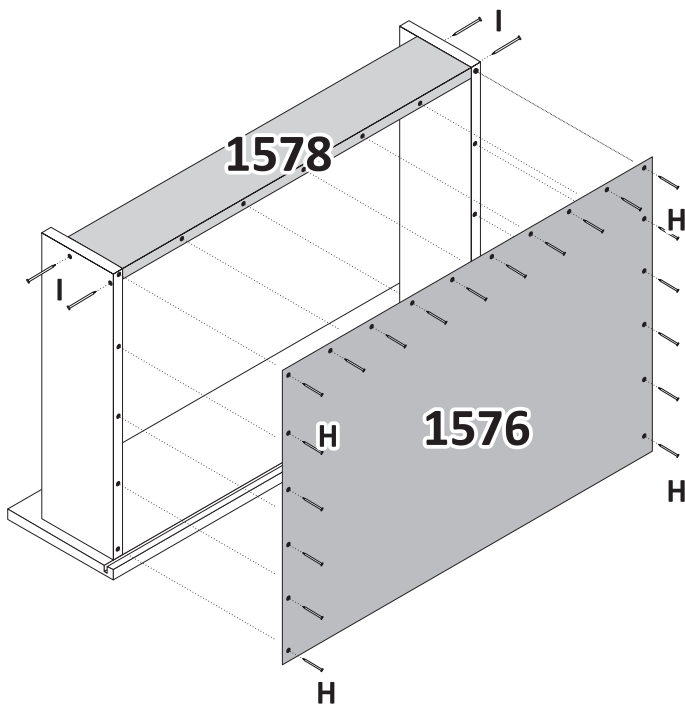
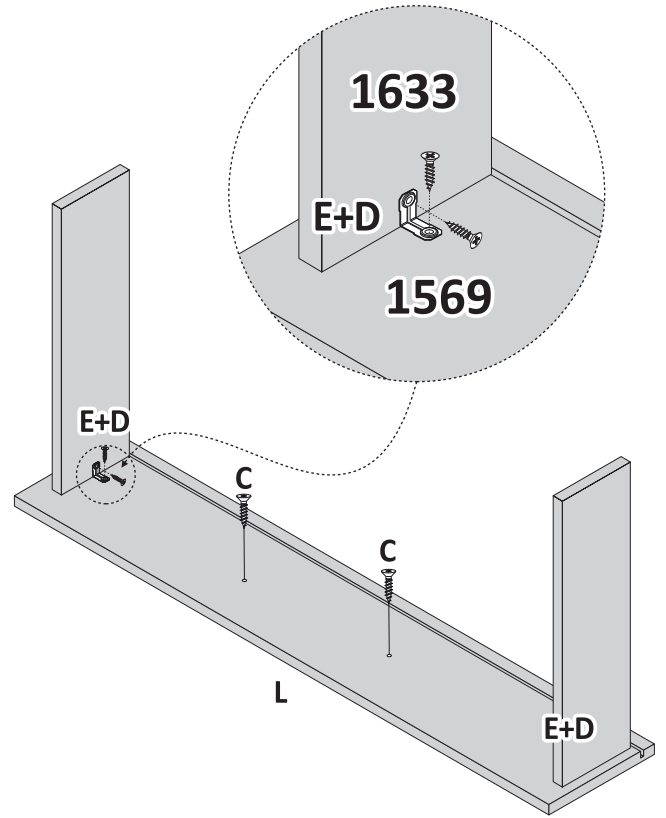
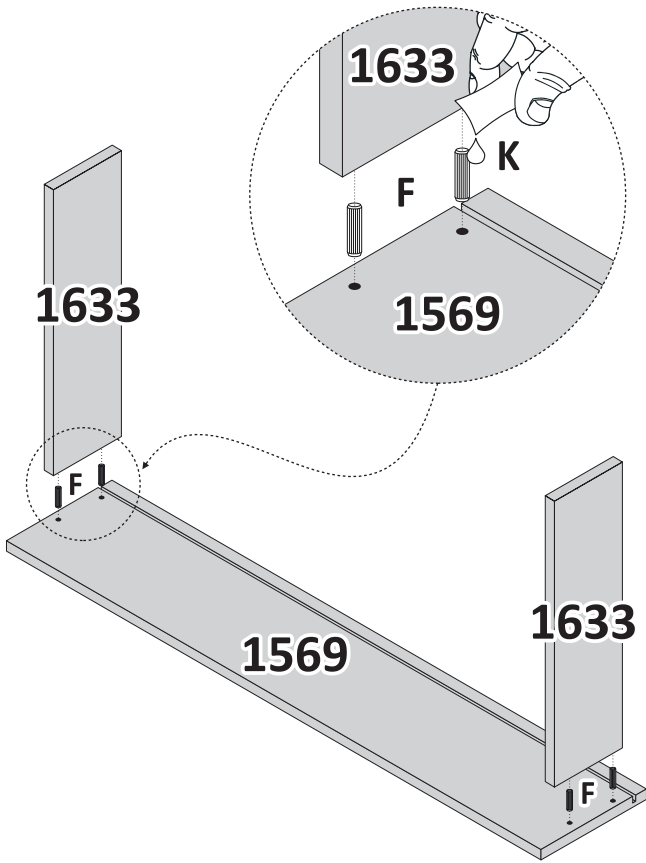

Produto montado.

Asembled product.
Producto ensamblado.

32 98887667
M





Doripel
móveis

Moveis.Doripel 

DoripelMoveis 

54 3358.6500 

Av. Julio Vanzin, 1600 - Área Industrial Lagoa Vermelha - RS - Brasil 

comercial@doripel.com.br | assistencia@doripel.com.br 

doripel.com.br 