

INSTRUCCIONES DE ARMADO / ASSEMBLY INSTRUCTIONS
MUEBLE MEDIANO BRYCE / BRYCE BASE CABINET

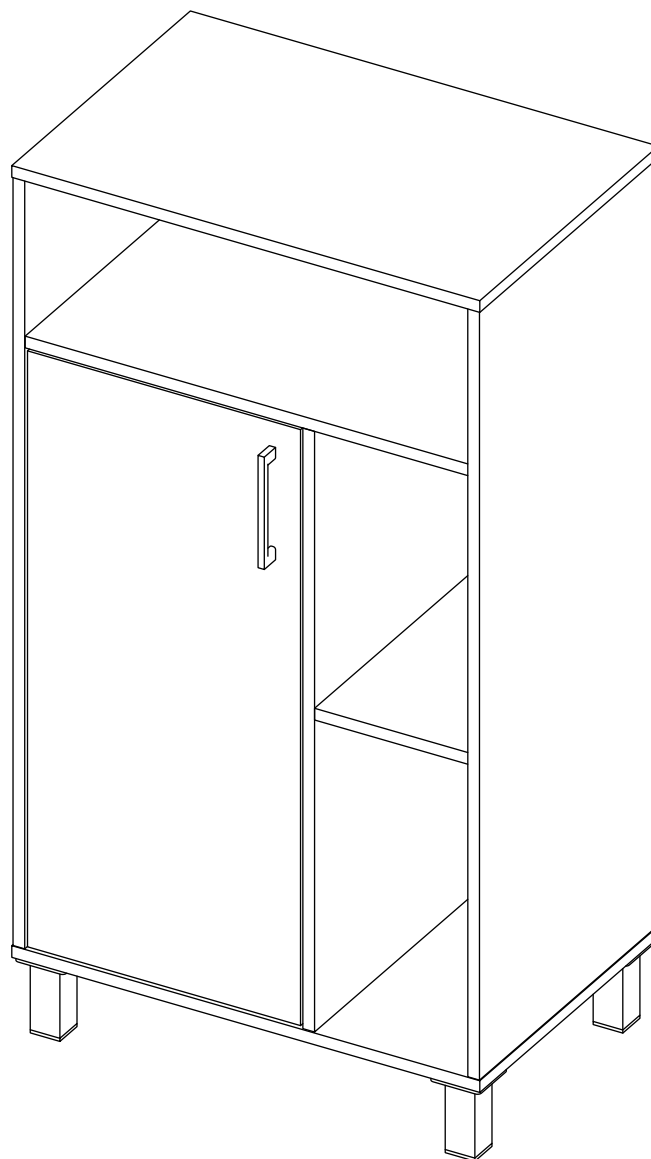

RTA[®]
m u e b l e s

Tel: (602) 695 9581 / 695 91 81 | EXT 118
La Nueva Estancia, Yumbo - Valle del Cauca - Colombia
www.rta.com.co

¡ATENCIÓN! / ATTENTION!

En las próximas páginas está el contenido de las piezas y herrajes del mueble. Asegúrate de que la cantidad de herrajes y piezas que hay en la caja sea la correcta y todo esté en buen estado. Ya que cuando el mueble esté armado no podrás realizar ninguna reposición.

On the next pages is the content of the pieces and hardware of the furniture. Make sure the number of hardware and parts in the box is correct and everything is in good condition. When the furniture is assembled you will not be able to make any replacement

Recomendaciones Importantes / Key Recommendations

- Ensamble el mueble entre dos personas. / Assemble the cabinet between two people.
- Ensamble el mueble sobre una superficie plana y lisa, preferiblemente sobre un tapete o el cartón de la caja. / Assemble the cabinet on a flat smooth surface, preferably on a carpeted floor or the box carton.
- Se recomienda utilizar un destornillador eléctrico para facilitar el ensamble / It is recommended to use an electric screwdriver to facilitate assembly.

Herramientas Necesarias / Required Tools



Destornillador de estrella
Phillips Head
Screwdriver



Destornillador de pala
Flat Head
Screwdriver

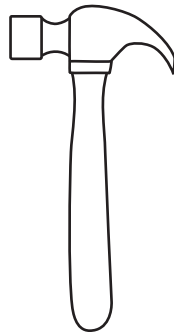

Martillo
Hammer

Herrajes Básicos / Basic Hardware

Aplica estas instrucciones cada vez que vayas a utilizar uno de estos herrajes durante el armado. / Apply these instructions everytime you're using one of these connectors during the assembly.

Tarugos / Wood Dowels

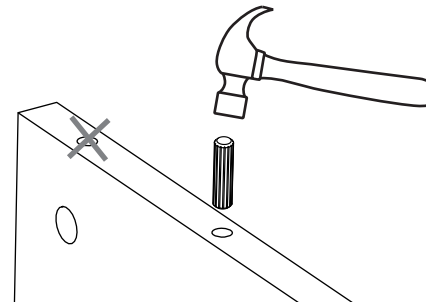

1. Inserta el tarugo en la perforación indicada y golpéalo suavemente hasta que llegue hasta el final de la perforación. / Put in the dowel inside the indicated hole and softly hit it until it's fully inside.
2. Verifica que NO se inserte el tarugo en la perforación de la caja minifix. / Verify that the dowel is NOT inserted into the perforation of the minifix cam.



Para más información
escanea AQUÍ
Scan for more info

Minifix y Pernos / Minifix Cam & Spreading Bolt

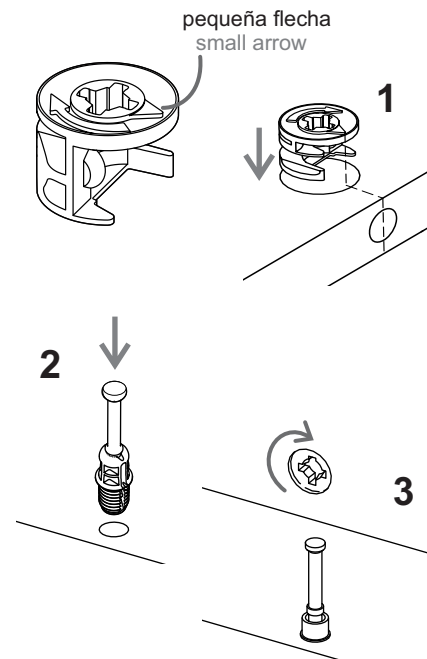

1. La caja minifix tiene una pequeña flecha en su parte superior, se debe insertar las cajas minifix con la flecha apuntando hacia la perforación que hay en el borde de la pieza. / The Minifix cam has a little arrow on its upper surface you should insert these cams with the little arrow pointing towards the drilling on the panel's edge.
2. Se debe insertar el perno con la parte plástica hacia abajo. / The spreading bolt should be put with the black plastic part facing down edge.
3. Luego de unir las piezas, se deben girar 180° las cajas minifix con un destornillador de estrella para ajustar y asegurar el ensamble. / After joining two panels together you should turn the cams 180° with a phillips head screwdriver to adjust and secure the joint.

Herrajes / Hardware

 <p>Tarugo / Wood dowel</p> <p>x24</p>	 <p>Perno Minifix / Spreading Bolt</p> <p>x10</p>	 <p>Caja Minifix / Minifix Cam</p> <p>x10</p>	 <p>Tapa Minifix / Cover Caps Color 1</p> <p>x5</p>
 <p>Pata aluminio / Aluminium Leg</p> <p>x4</p>	 <p>Manija / Handle</p> <p>x1</p>	 <p>Puntilla / Nail</p> <p>x30</p>	 <p>Tornillo lámina / Flat Head Screw</p> <p>x16</p>
 <p>Chazo + tornillo ensamble / Wall anchor + drywall screw</p> <p>x2</p>	 <p>Tornillo ensamble / Drywall screw</p> <p>x3</p>	 <p>Bisagra interior / Hinge + screws</p> <p>x2</p>	 <p>Grapa unión fondos / Rear panel clamp</p> <p>x5</p>
 <p>Soporte entrepaña / Shelf support</p> <p>x5</p>	 <p>Tapa Minifix / Cover Caps Color 2</p> <p>x7</p>		

Cargas Máximas / Max Suggested Loads

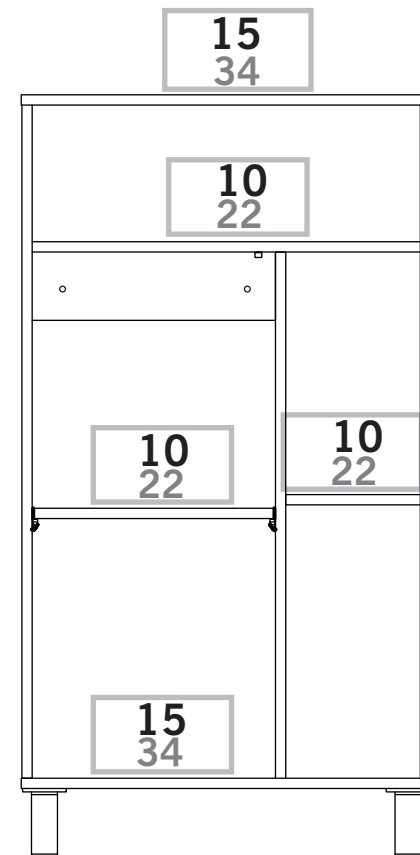

*Peso en Kg / Weight in Kg.

*Peso en Libras / Weight in Lb

Piezas de Armado / Assembly Parts

A - x1	M - x1
B - x1	
C - x1	
D - x1	
E - x1	
F - x1	
G - x1	
H - x1	
I - x1	
J - x1	
K - x1	
L - x1	

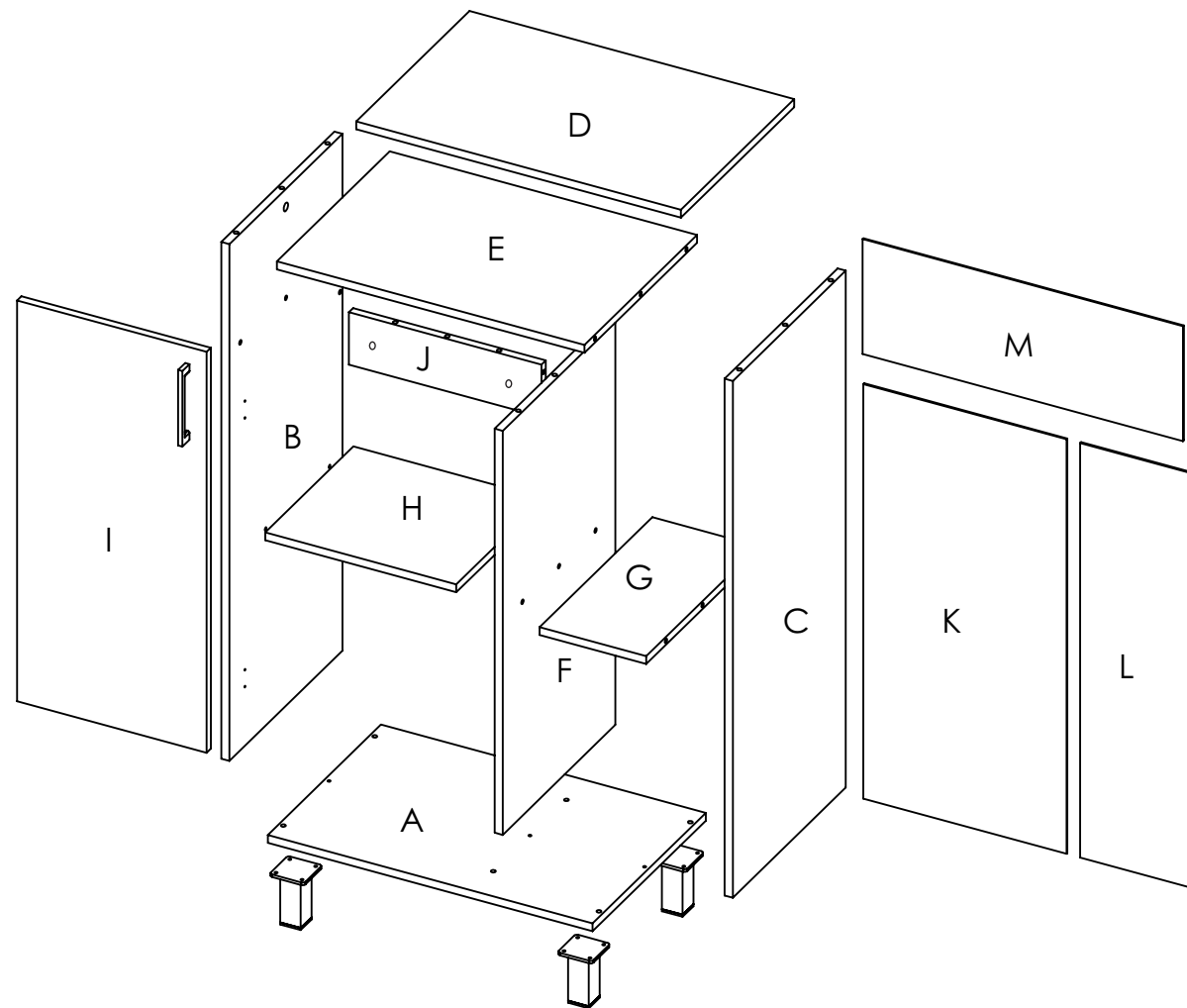

1

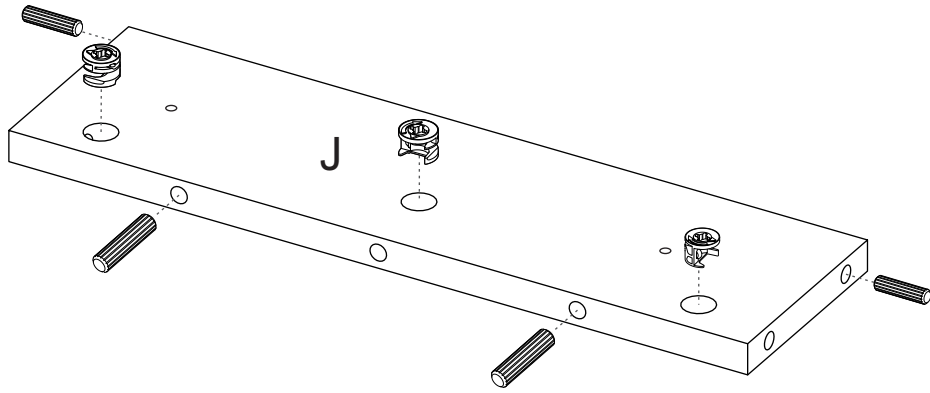

2

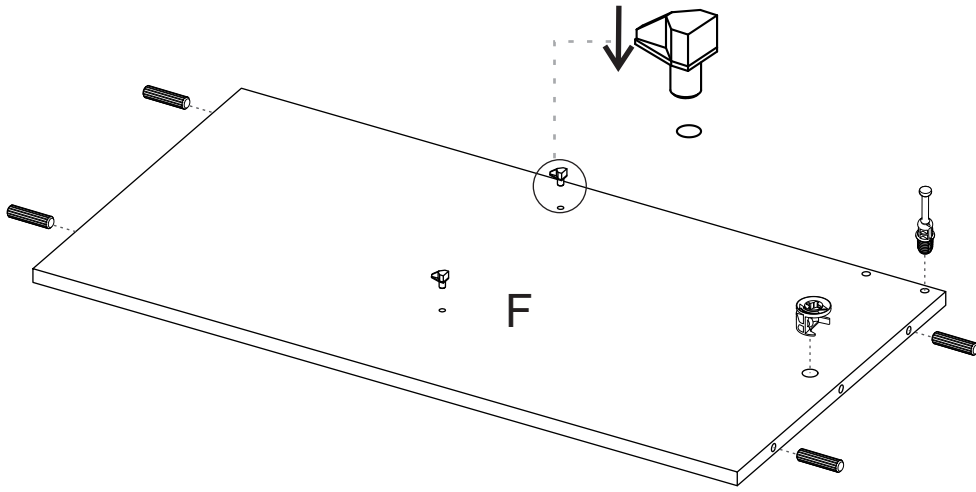

3

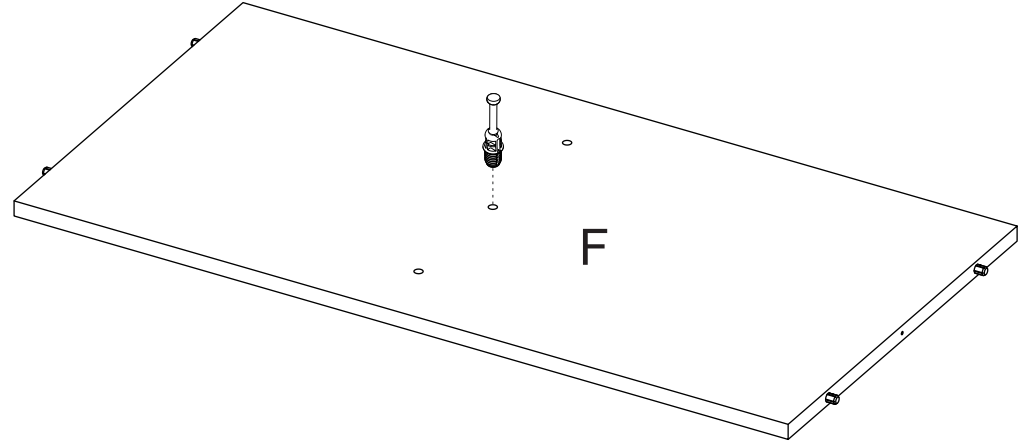

4

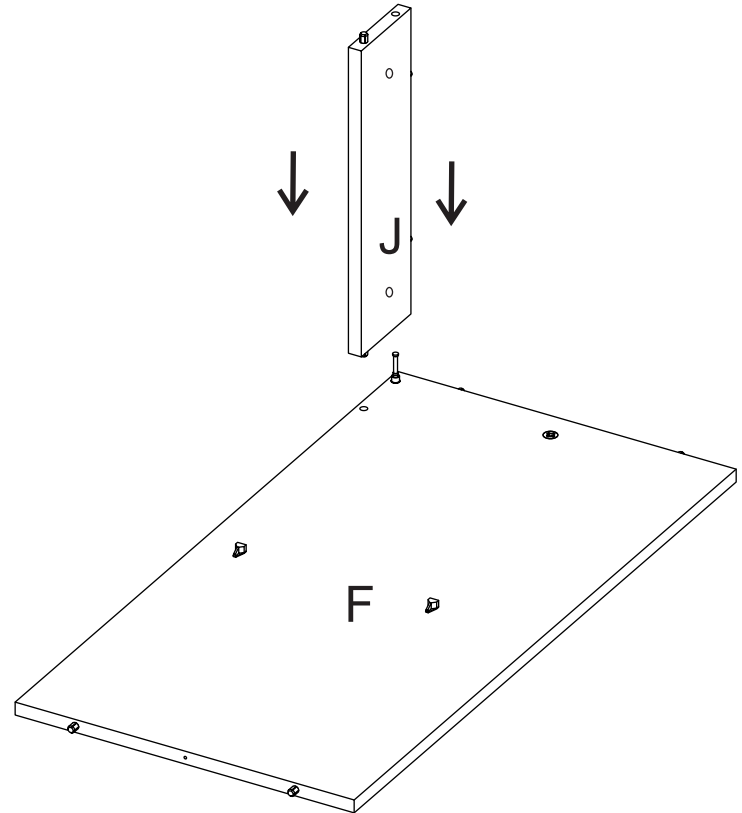

5

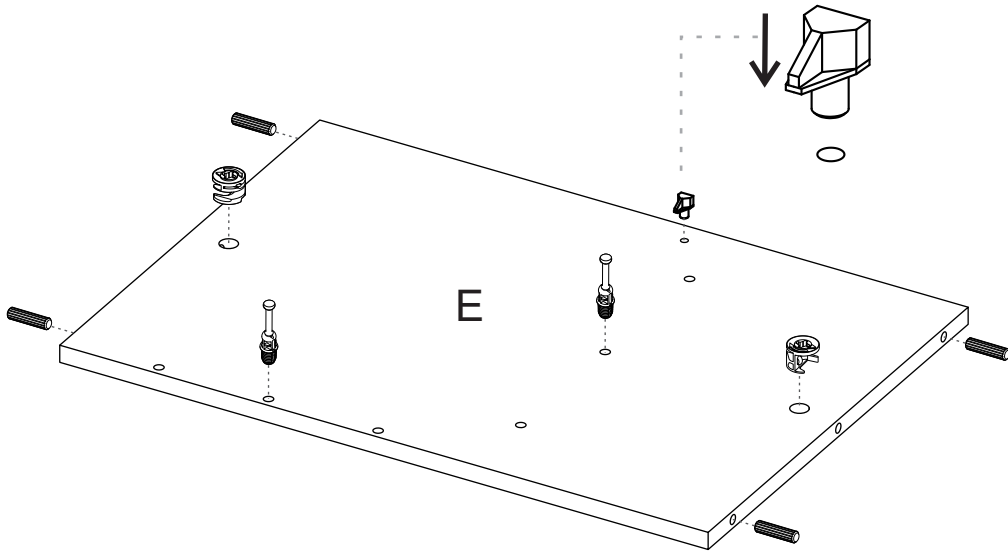

7

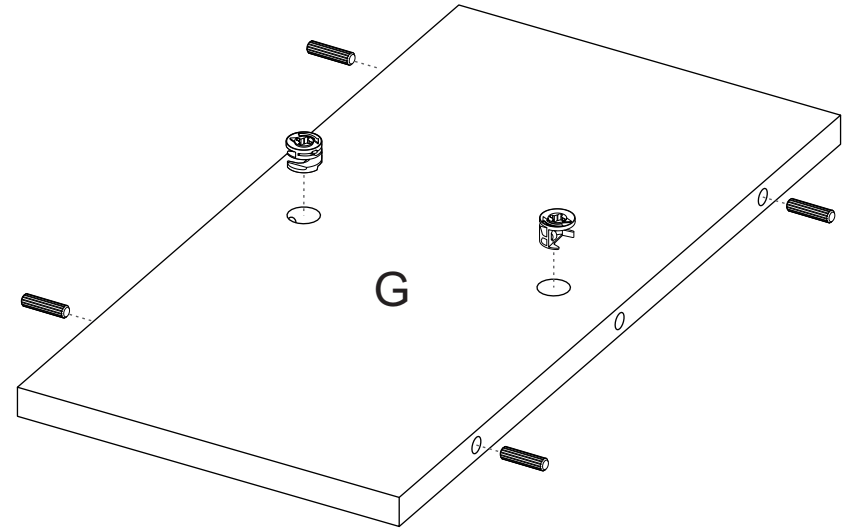

6

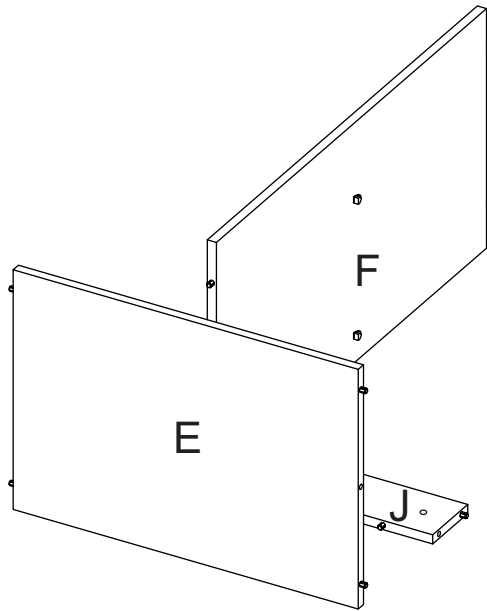

8

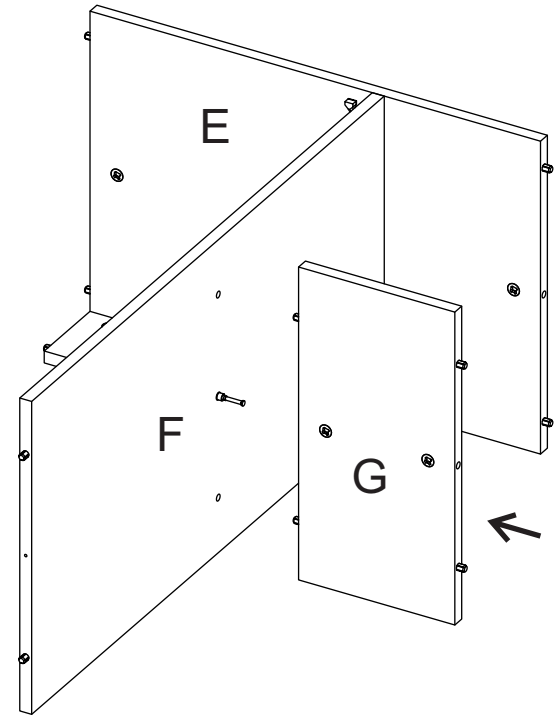

9

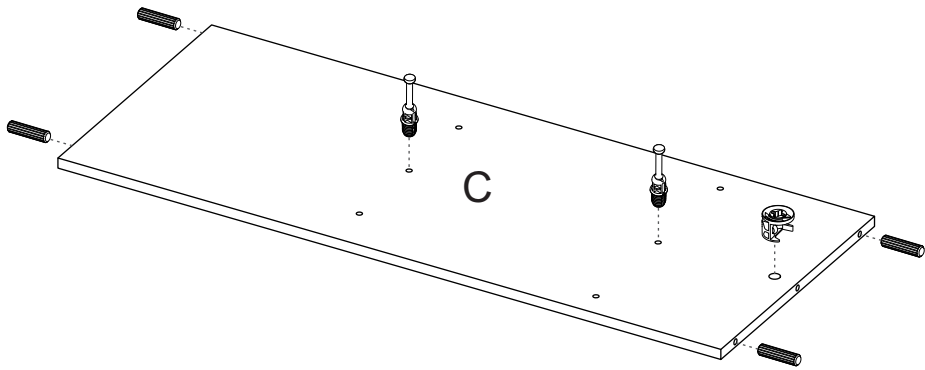

11

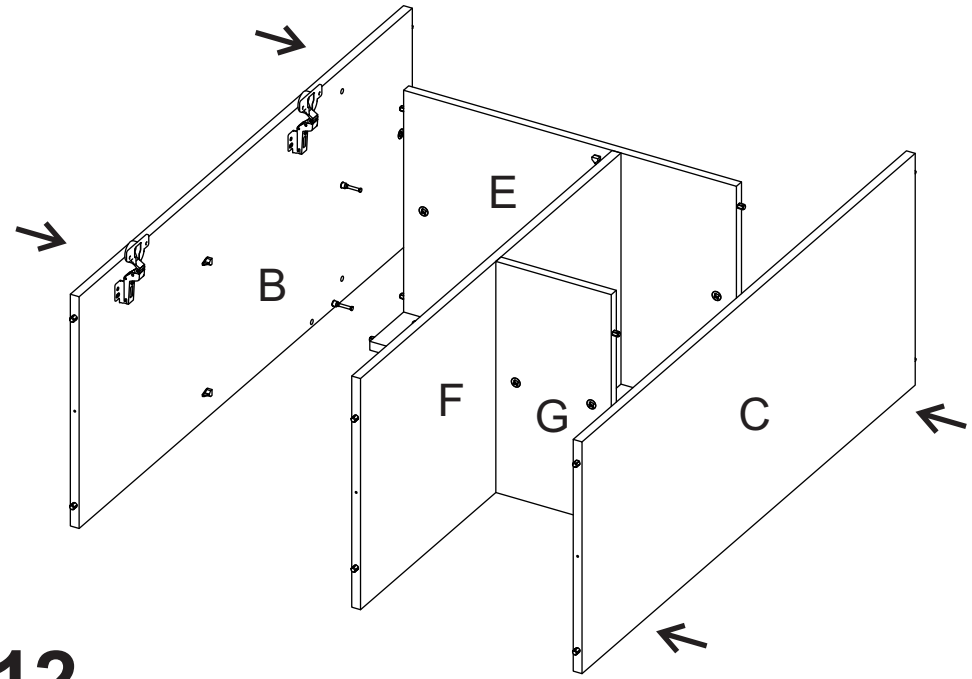

10

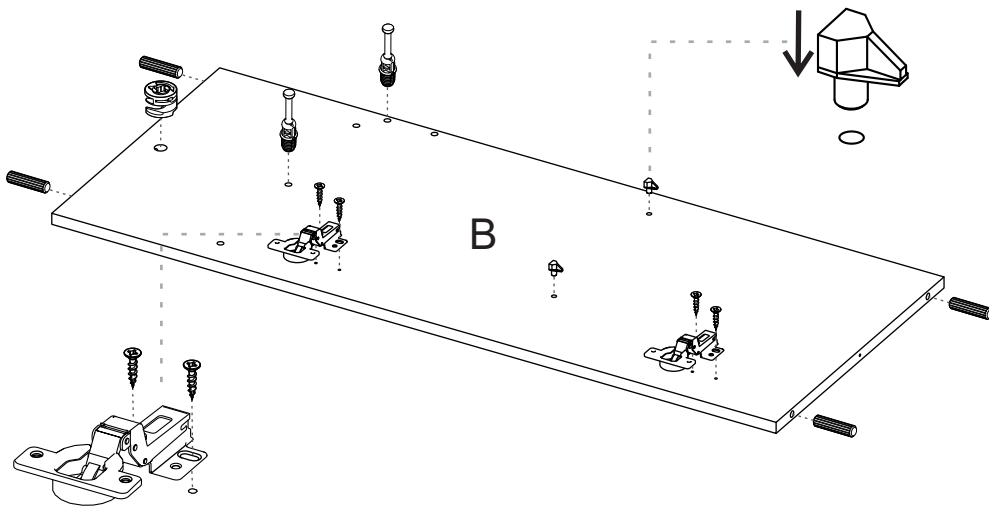

12

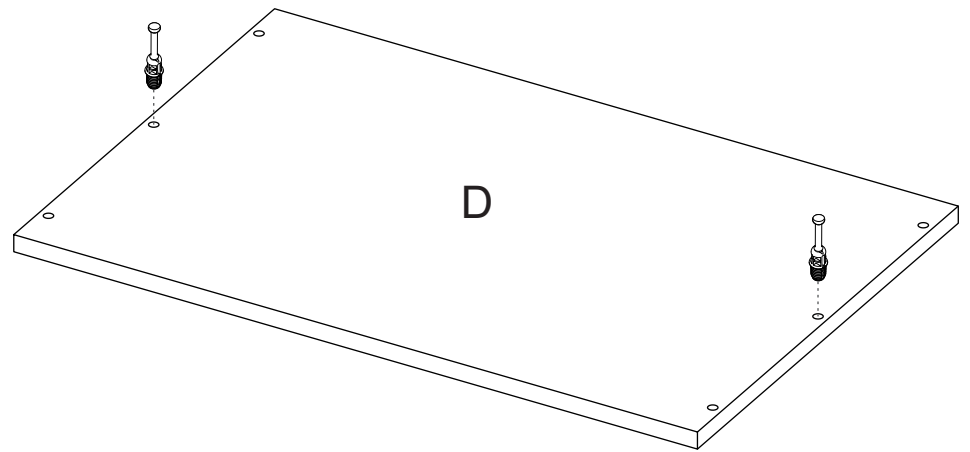

13

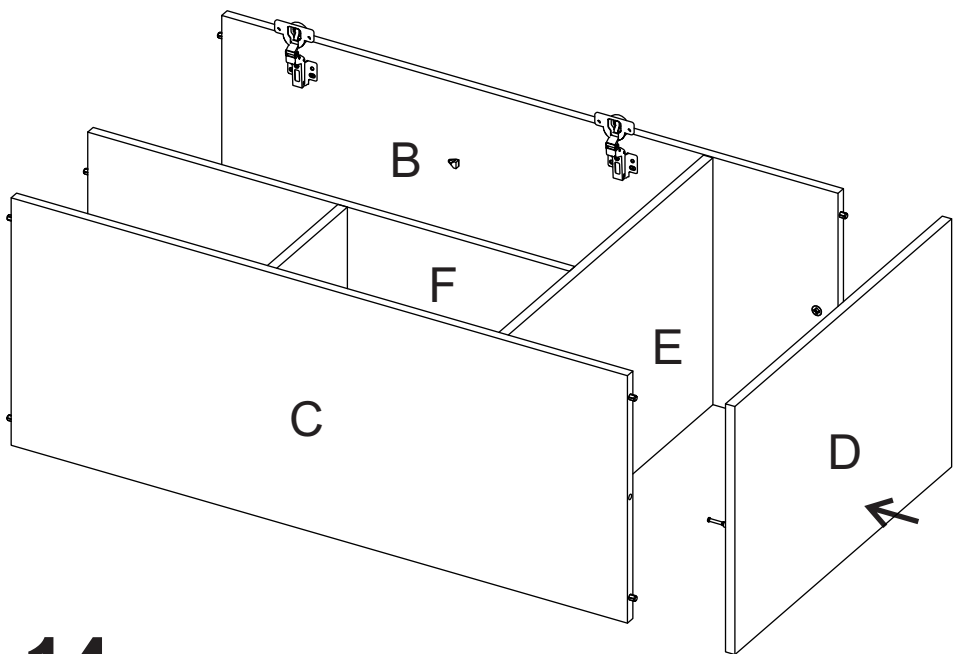

14

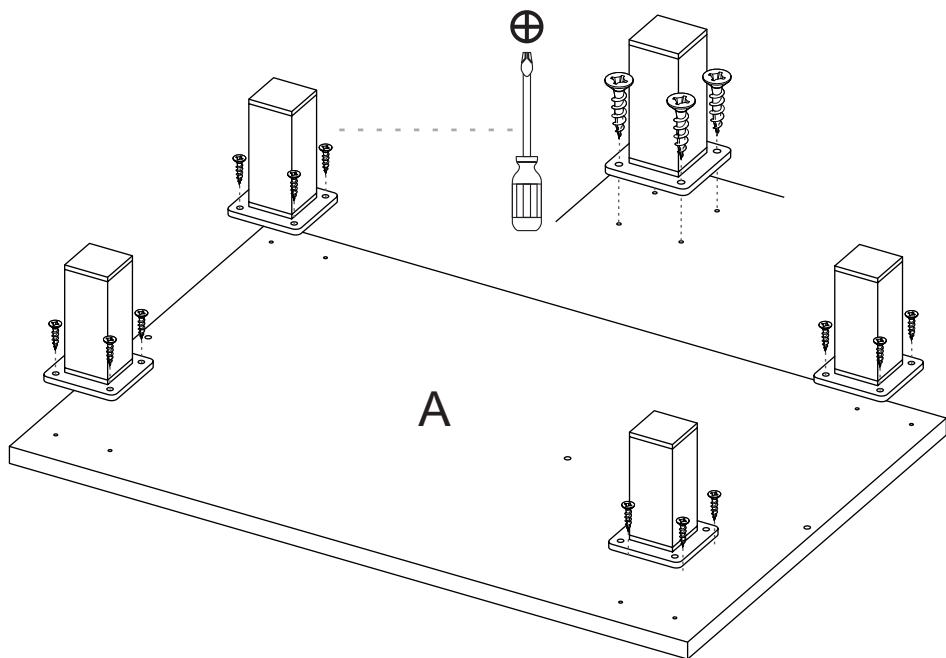

15

Tornillo
ensamble 2"
/ Drywall
screw 2"

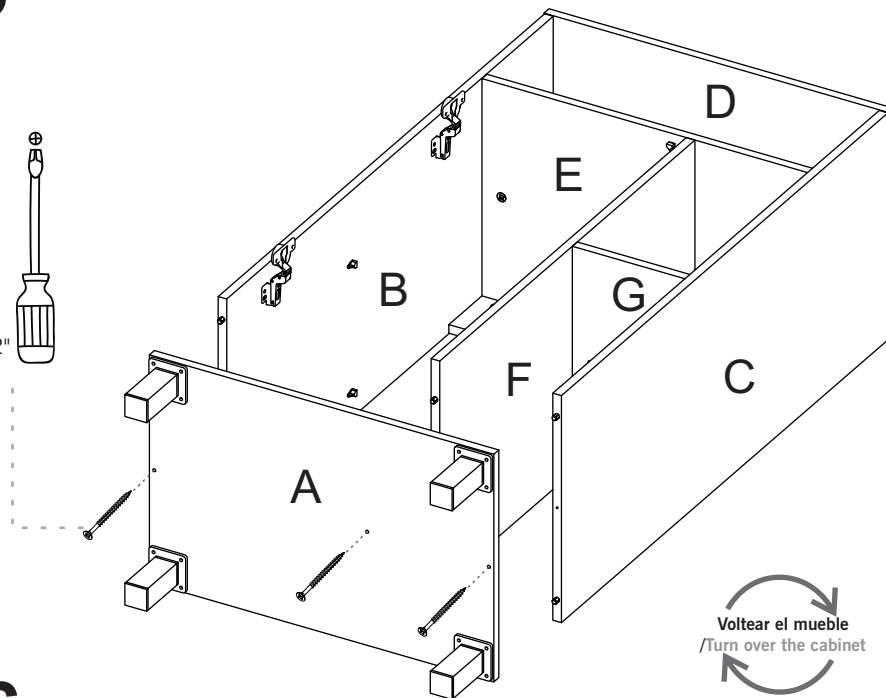
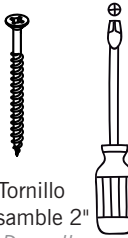

Voltear el mueble
/ Turn over the cabinet

16

Cierra las bisagras antes
de voltear el mueble
/ Close the Hinges before
flip the cabinet.

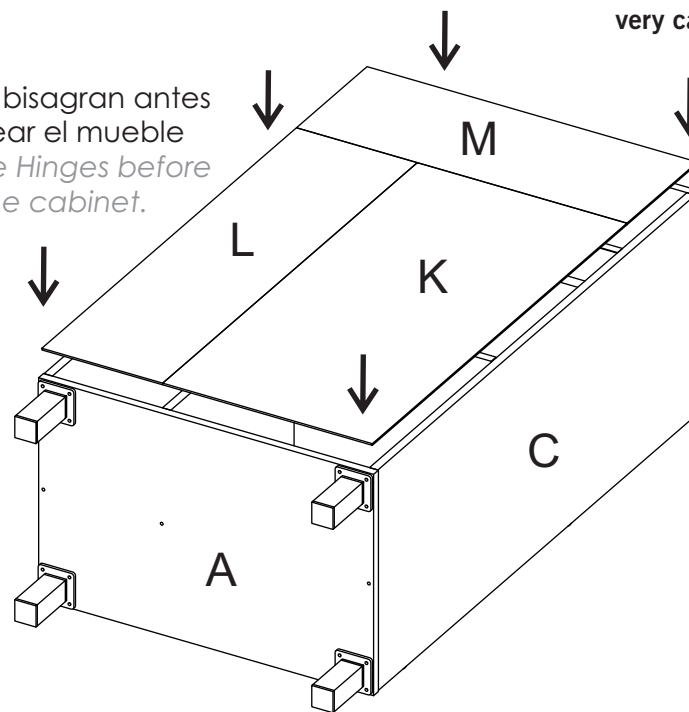

¡Con mucho cuidado!
very carefully!

17

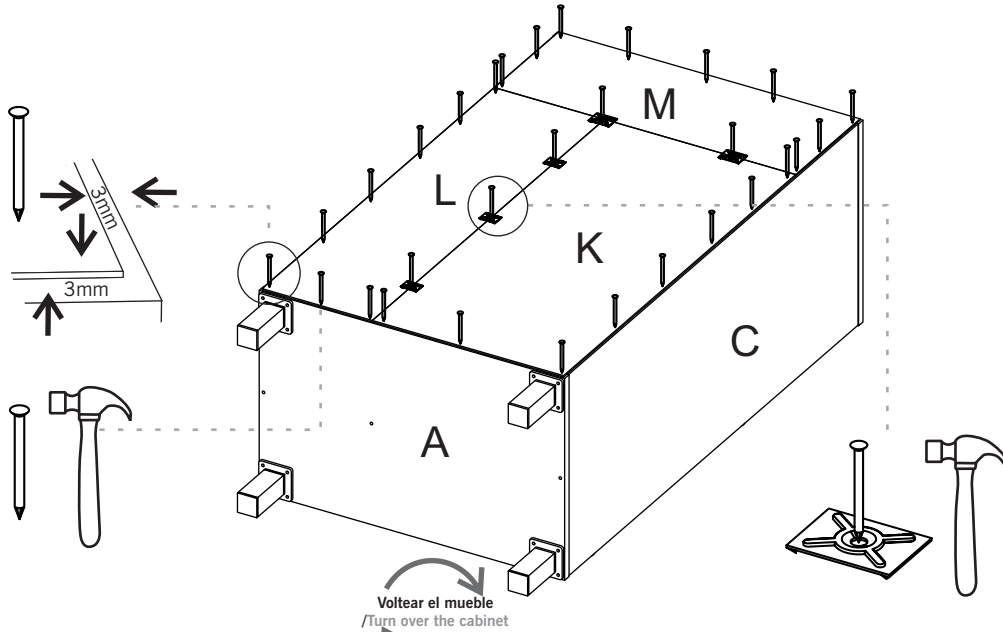

Voltear el mueble
/ Turn over the cabinet

**¡Con mucho cuidado!
very carefully!**

18

Desliza el entrepaño dentro
del mueble
/ Slide the shelf
inside the cabinet.

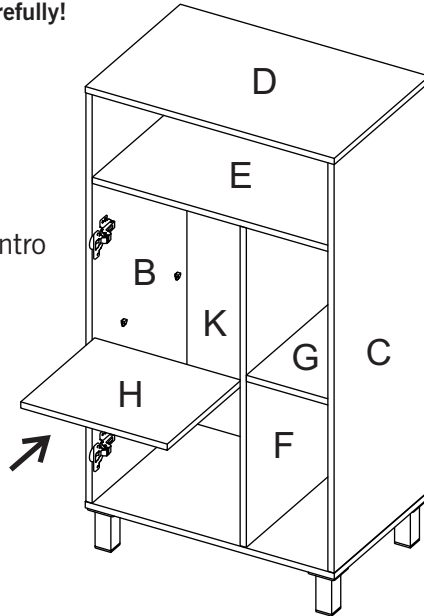

19

Fija el mueble a la pared Fix your cabinet to the wall

- 1 Debes perforar los fondos guiándote por los agujeros en las estructuras con una broca de 3/16".
You must drill the bottoms guided by the holes in the structures with a 3/16" drill bit.
- 2 En la pared, mide y marca los puntos que te indicamos abajo.
On the wall, measure and mark the points shown below.
- 3 Debes perforar en los puntos con taladro y una broca de 5/16".
Drill on the markings with a 5/16" drill bit.
- 4 Inserta los chazos plásticos en las perforaciones.
Insert the wall anchors inside the drillings.
- 5 Ubica el mueble y asegúralo con los tornillos.
Place the cabinet and secure it with the screws.

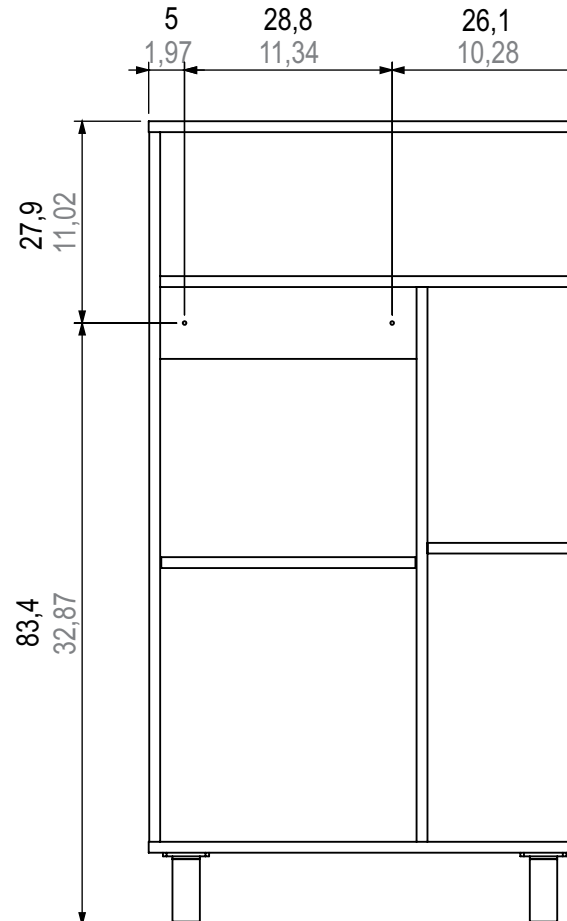
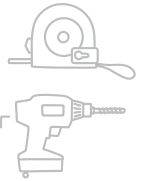

*Medidas en cm / Measurements in cm
*Medidas en pulgadas / Measurements in inches

20 Instalación de la puerta Door Installation

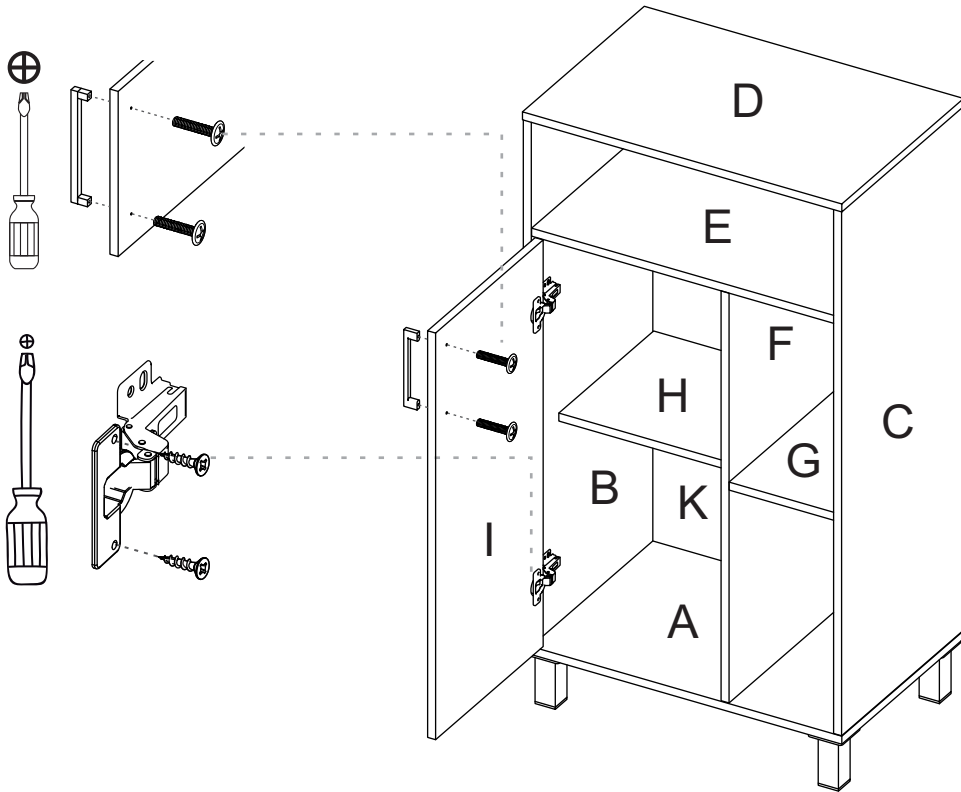

Seguir las instrucciones de ajuste de la siguiente página.
Follow the adjustment instructions on the next page. →

21 Ajuste de las bisagras Hinge adjustment

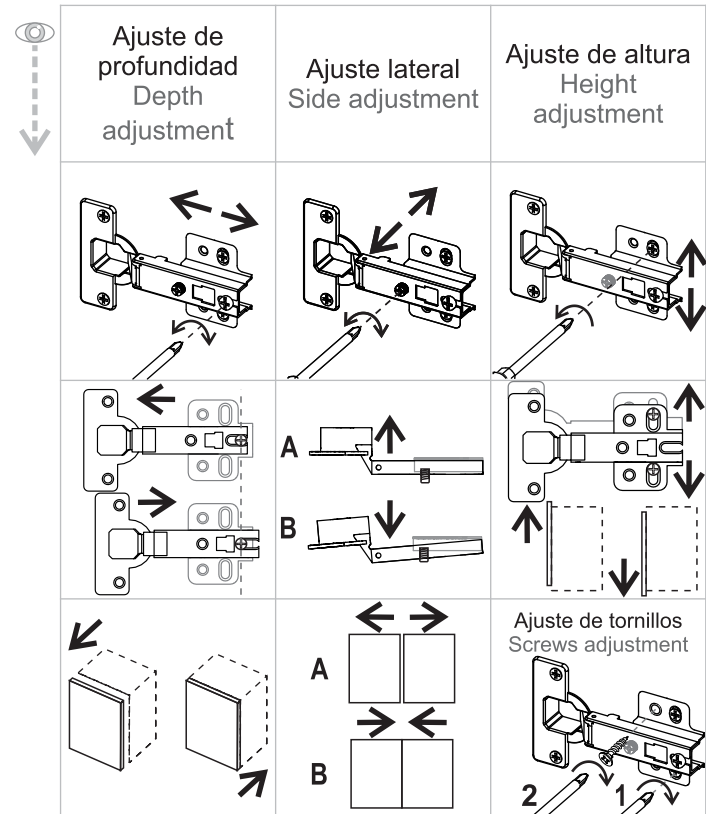

Usar los ajustes según la necesidad específica.
Use the settings according to the specific need.

Para más información escanea AQUÍ/Scan for more info

Bisagras/ Hinge



Tapas minifix/
Cover caps

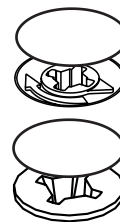

Después de ajustar todas las cajas minifix y los tornillos, cúbralas con las tapas adhesivas.
After you finish the adjustment of the cams and screws, cover them with the cover caps.



Al terminar de armar, desprenda las letras adhesivas.
After you finish assembling the cabinet, take off the adhesive letters.