

INSTRUCCIONES DE ARMADO / ASSEMBLY INSTRUCTIONS CENTRO DE COMPUTO CON BIBLIOTECA ALDEN ECO / ALDEN ECO COMPUTER CENTER WITH LIBRARY

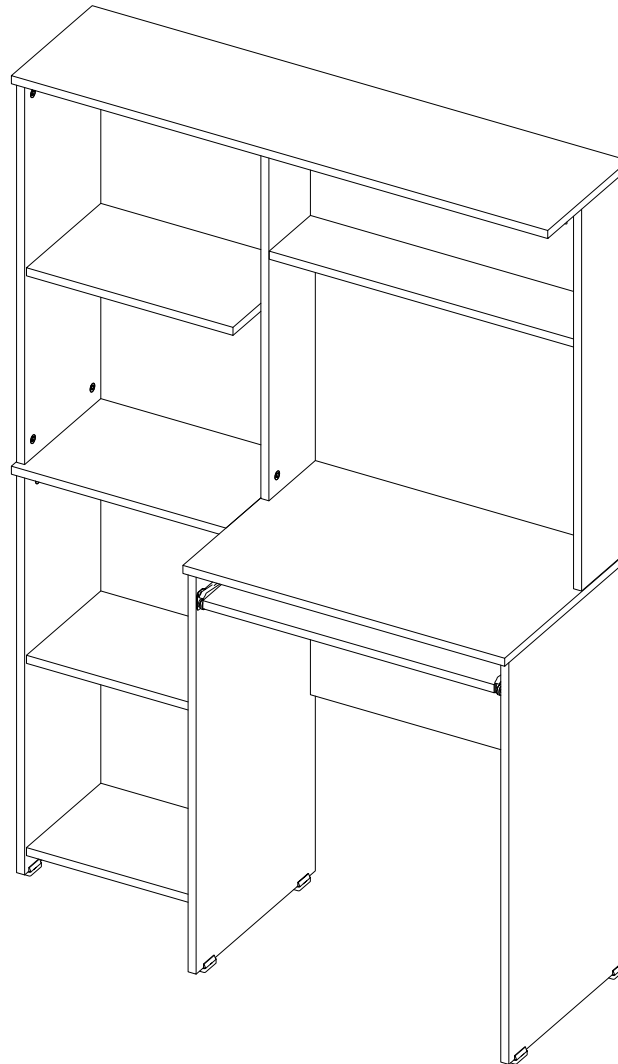

Conviertete en cliente VIP
Escanea aquí!

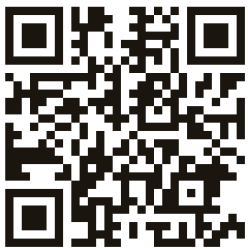

- ✓ Garantía extendida
- ✓ Asesoría personalizada
- ✓ Últimas tendencias de diseño y nuevos lanzamientos

RTA[®]
m u e b l e s

Tel: (602) 695 9581 / 695 91 81 | EXT 118
La Nueva Estancia, Yumbo - Valle del Cauca - Colombia
www.rta.com.co

¡ATENCIÓN! / ATTENTION!

En las próximas páginas está el contenido de las piezas y herrajes del mueble. Asegúrate de que la cantidad de herrajes y piezas que hay en la caja sea la correcta y todo esté en buen estado. Ya que cuando el mueble esté armado no podrás realizar ninguna reposición.

On the next pages is the content of the pieces and hardware of the furniture. Make sure the number of hardware and parts in the box is correct and everything is in good condition. When the furniture is assembled you will not be able to make any replacement

Recomendaciones Importantes / Key Recommendations

- Ensamble el mueble entre dos personas. / Assemble the cabinet between two people.
- Ensamble el mueble sobre una superficie plana y lisa, preferiblemente sobre un tapete o el cartón de la caja. / Assemble the cabinet on a flat smooth surface, preferably on a carpeted floor or the box carton.
- Se recomienda utilizar un destornillador eléctrico para facilitar el ensamble / It is recommended to use an electric screwdriver to facilitate assembly.

Herramientas Necesarias / Required Tools

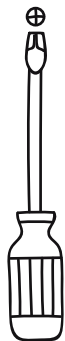

Destornillador de estrella
Phillips Head
Screwdriver

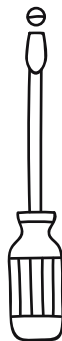

Destornillador de pala
Flat Head
Screwdriver

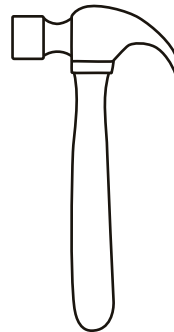

Martillo
Hammer

Herrajes Básicos / Basic Hardware

Aplica estas instrucciones cada vez que vayas a utilizar uno de estos herrajes durante el armado. / Apply these instructions everytime you're using one of these connectors during the assembly.

Tarugos / Wood Dowels

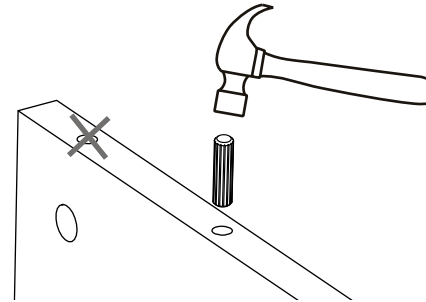

1. Inserta el tarugo en la perforación indicada y golpéalo suavemente hasta que llegue hasta el final de la perforación. / Put in the dowel inside the indicated hole and softly hit it until it's fully inside.

2. Verifica que NO se inserte el tarugo en la perforación de la caja minifix. / Verify that the dowel is NOT inserted into the perforation of the minifix cam.

Minifix y Pernos / Minifix Cam & Spreading Bolt

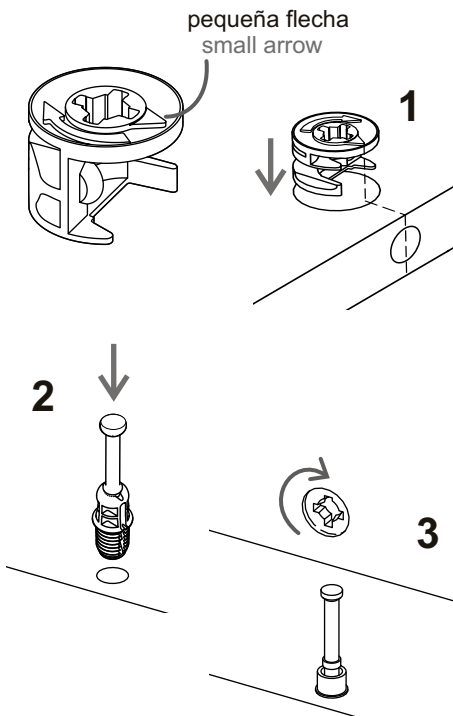





1. La caja minifix tiene una pequeña flecha en su parte superior, se debe insertar las cajas minifix con la flecha apuntando hacia la perforación que hay en el borde de la pieza. / The Minifix cam has a little arrow on its upper surface you should insert these cams with the little arrow pointing towards the drilling on the panel's edge.

2. Se debe insertar el perno con la parte plástica hacia abajo. / The spreading bolt should be put with the black plastic part facing down.

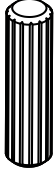
3. Luego de unir las piezas, se deben girar 180° las cajas minifix con un destornillador de estrella para ajustar y asegurar el ensamble. / After joining two panels together you should turn the cams 180° with a phillips head screwdriver to adjust and secure the joint.

Herrajes / Hardware

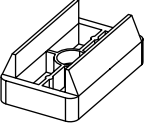
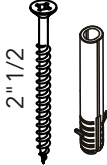
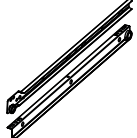
			
Tarugo / Wood dowel	Perno Minifix / Spreading Bolt	Caja Minifix / Minifix Cam	Tapa Minifix / Cover Caps
x19	x36	x36	x40
			
Tornillo lámina / Flat head screw	Deslizador en U / U-Slider	Chazo + Tornillo / Wall anchor + screw	Rieles + tornillos / Slides + screws
x6	x6	x2	x1

Cargas Máximas / Max Suggested Loads

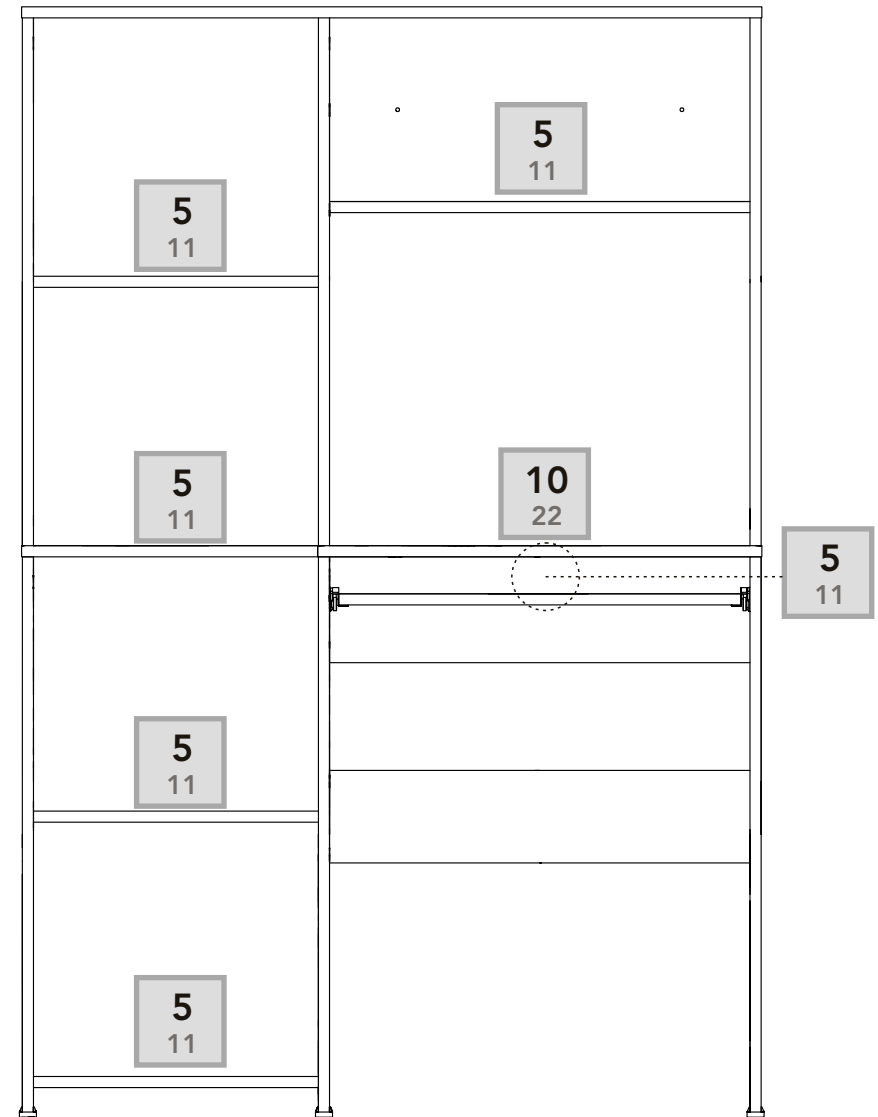

*Peso en Kg / Weight in Kg.

*Peso en Libras / Weight in Lb

Piezas de Armado / Assembly Parts

A - x1
B - x1
C - x1
D - x1
E - x1
F - x1
G - x1
H - x1
I - x1
J - x1
K - x1
L - x2
M - x1
N - x1
O - x1
P - x1

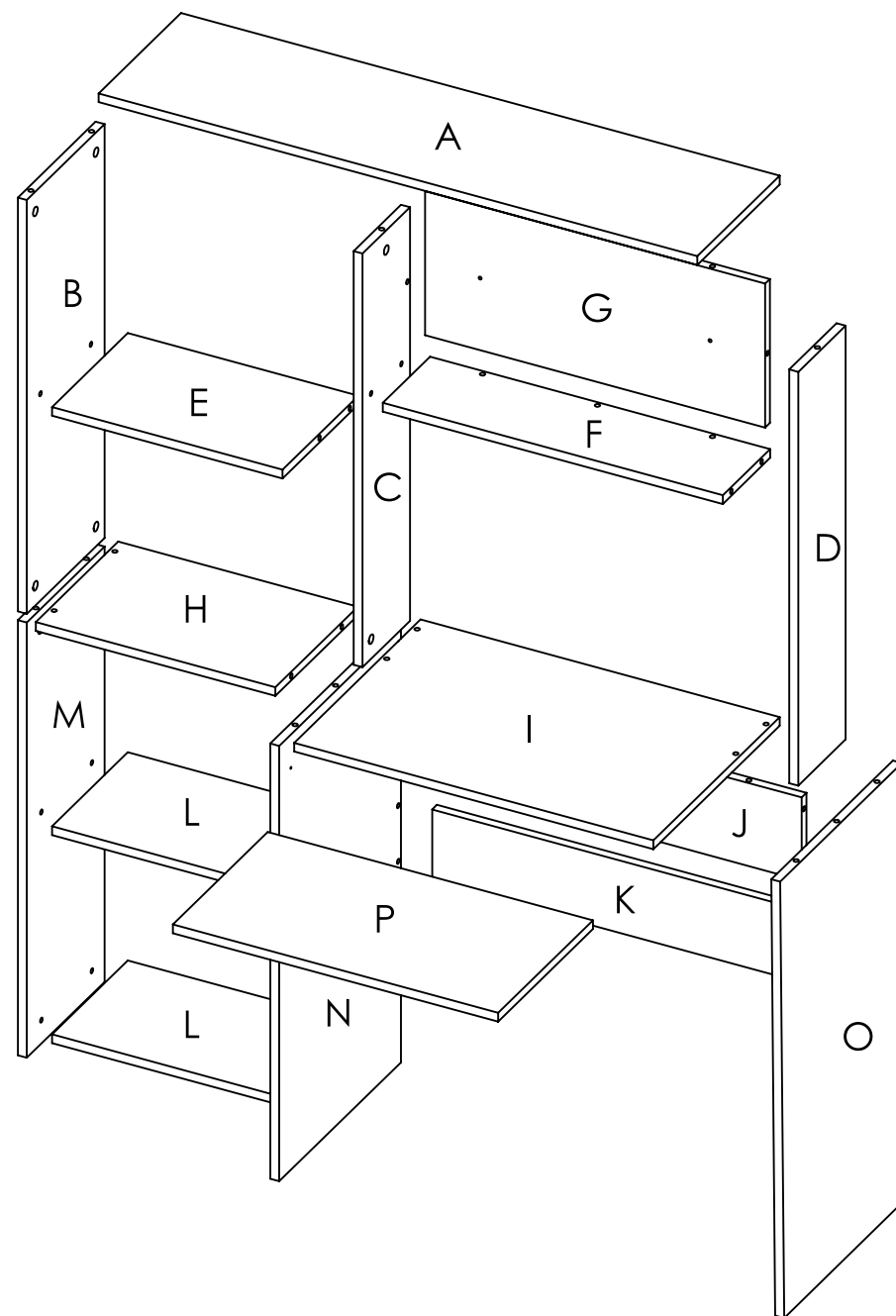

1

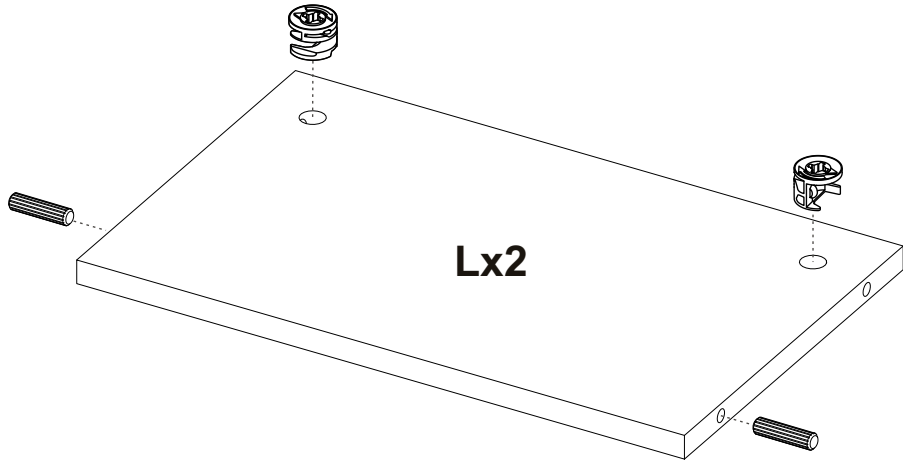

2

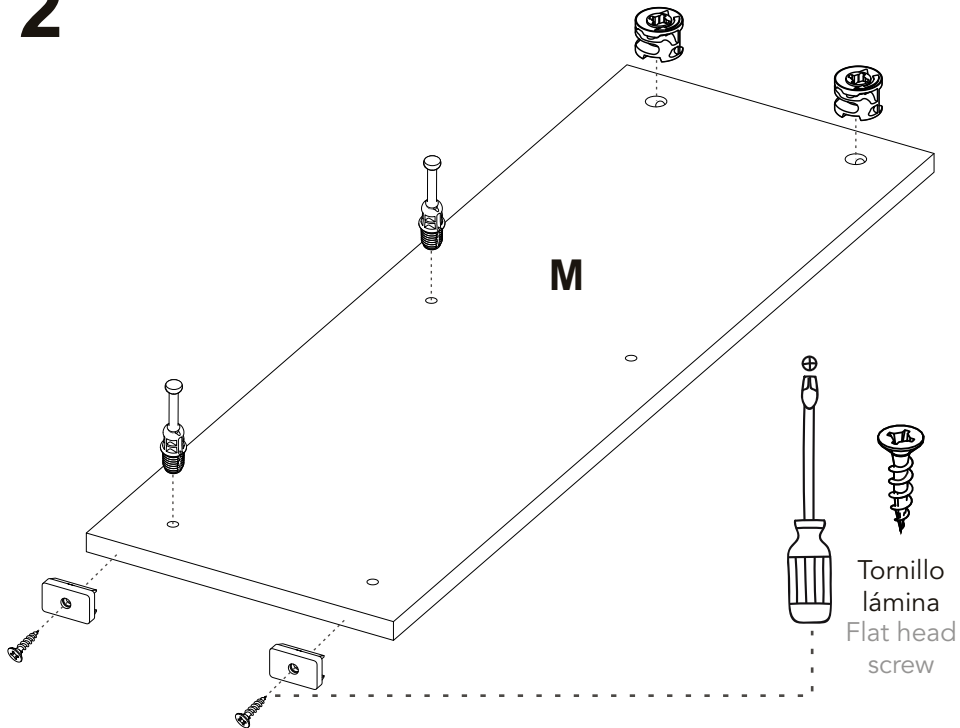

3

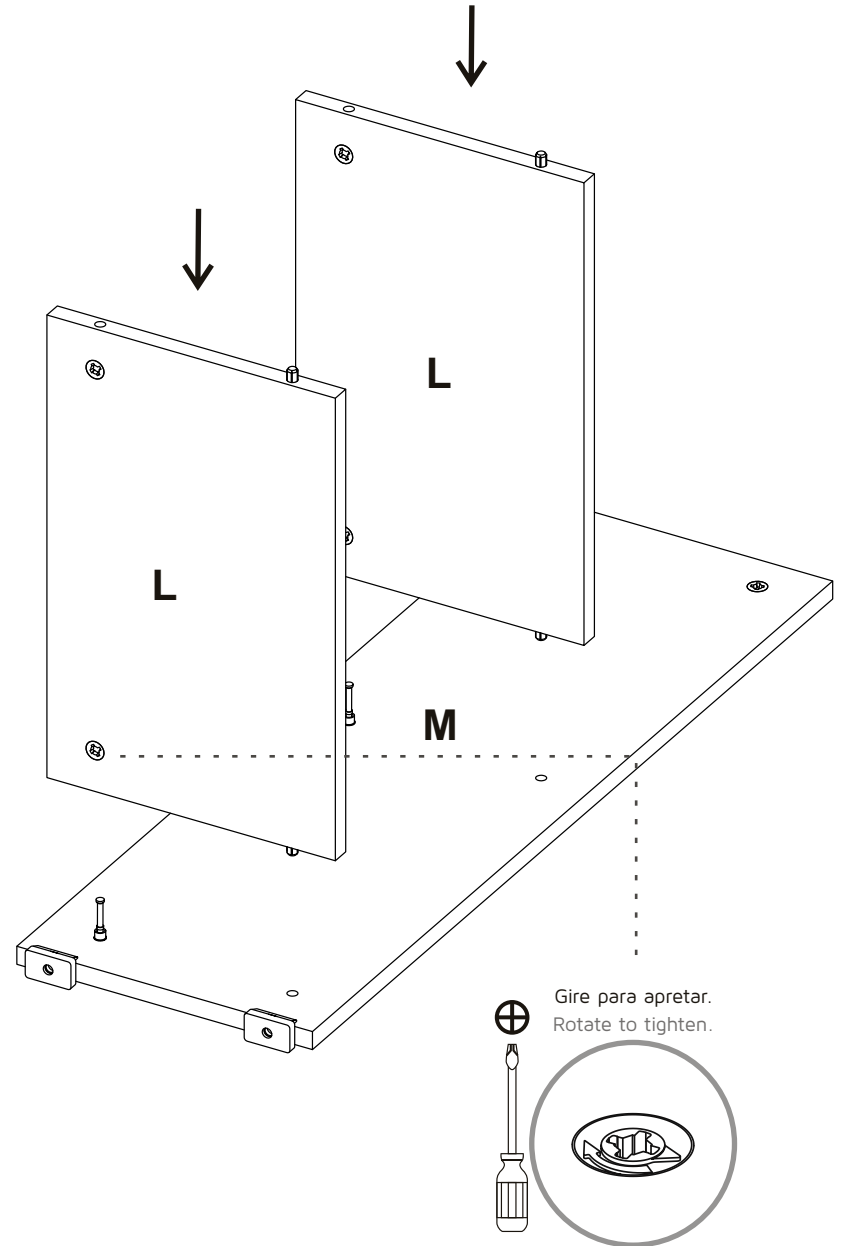

4

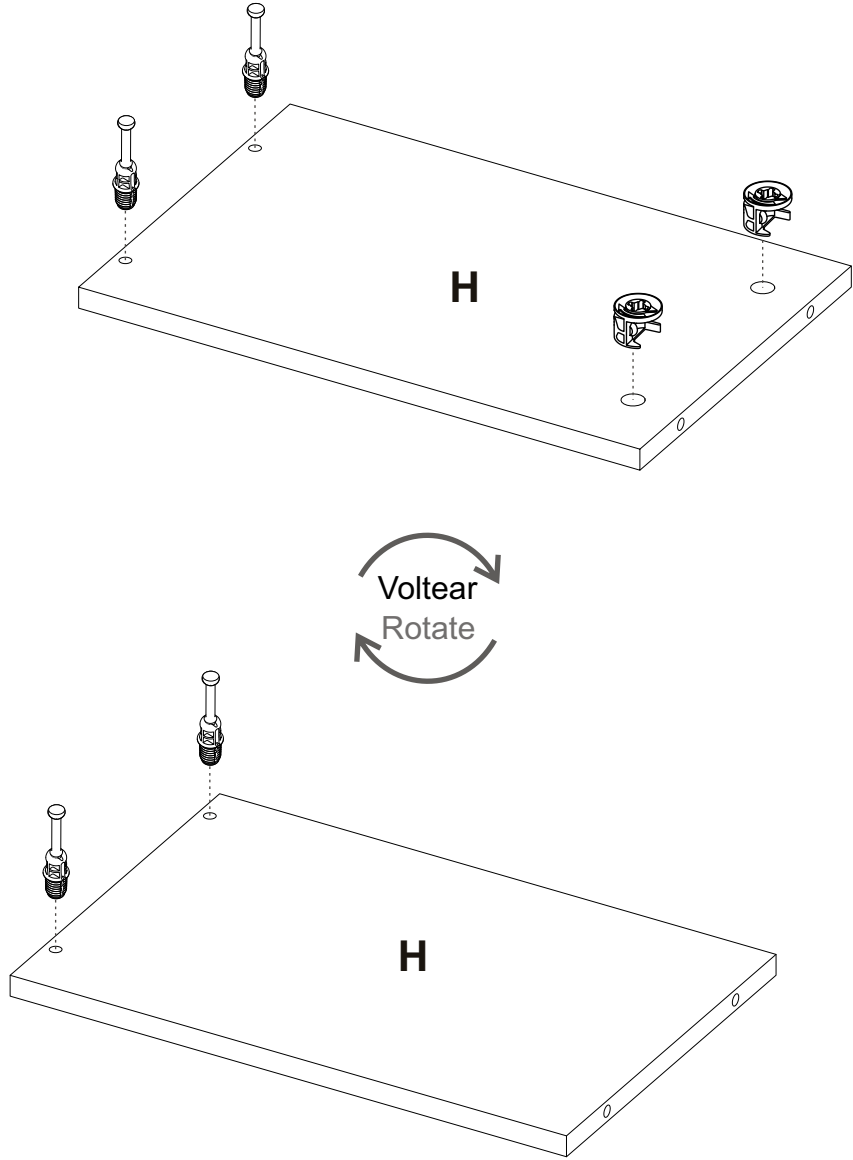

5

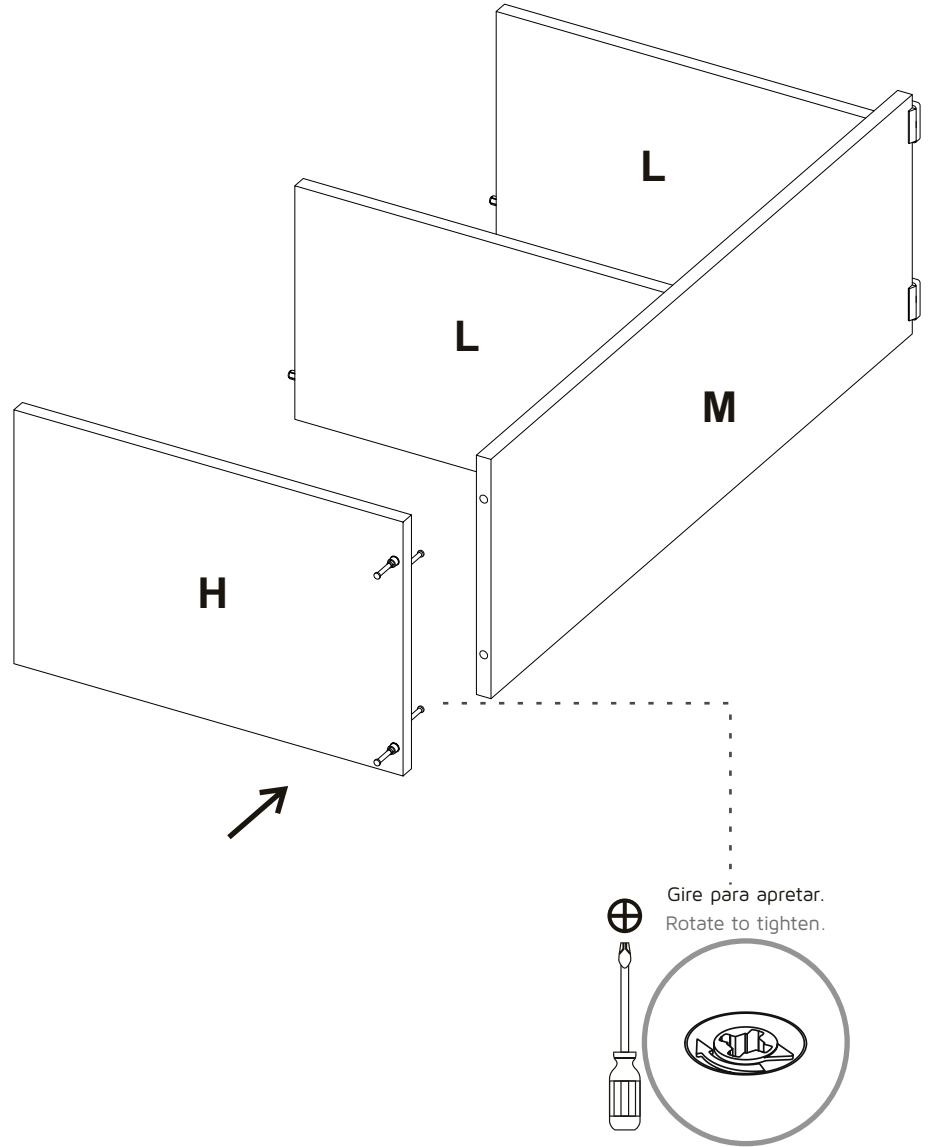

6

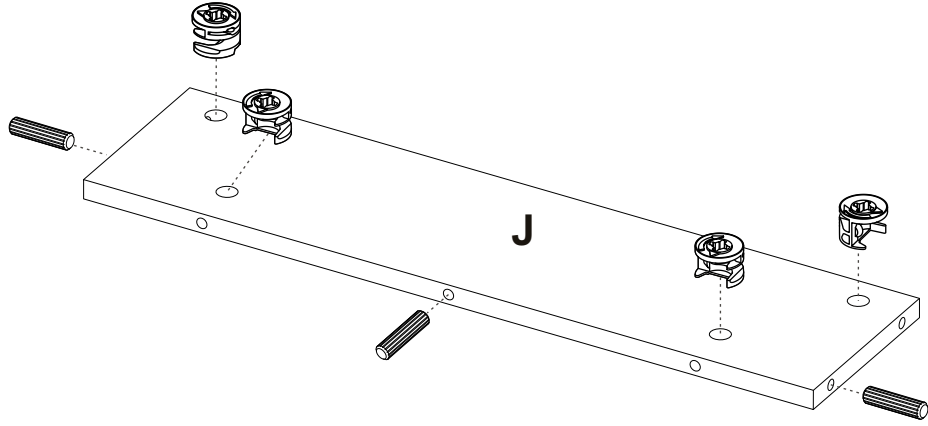

7

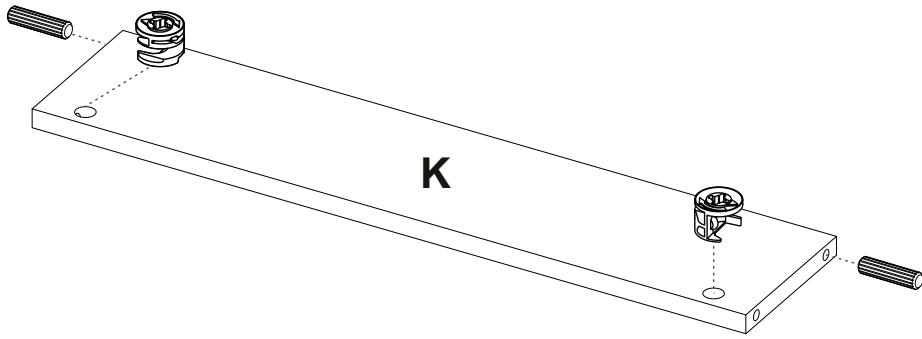

8

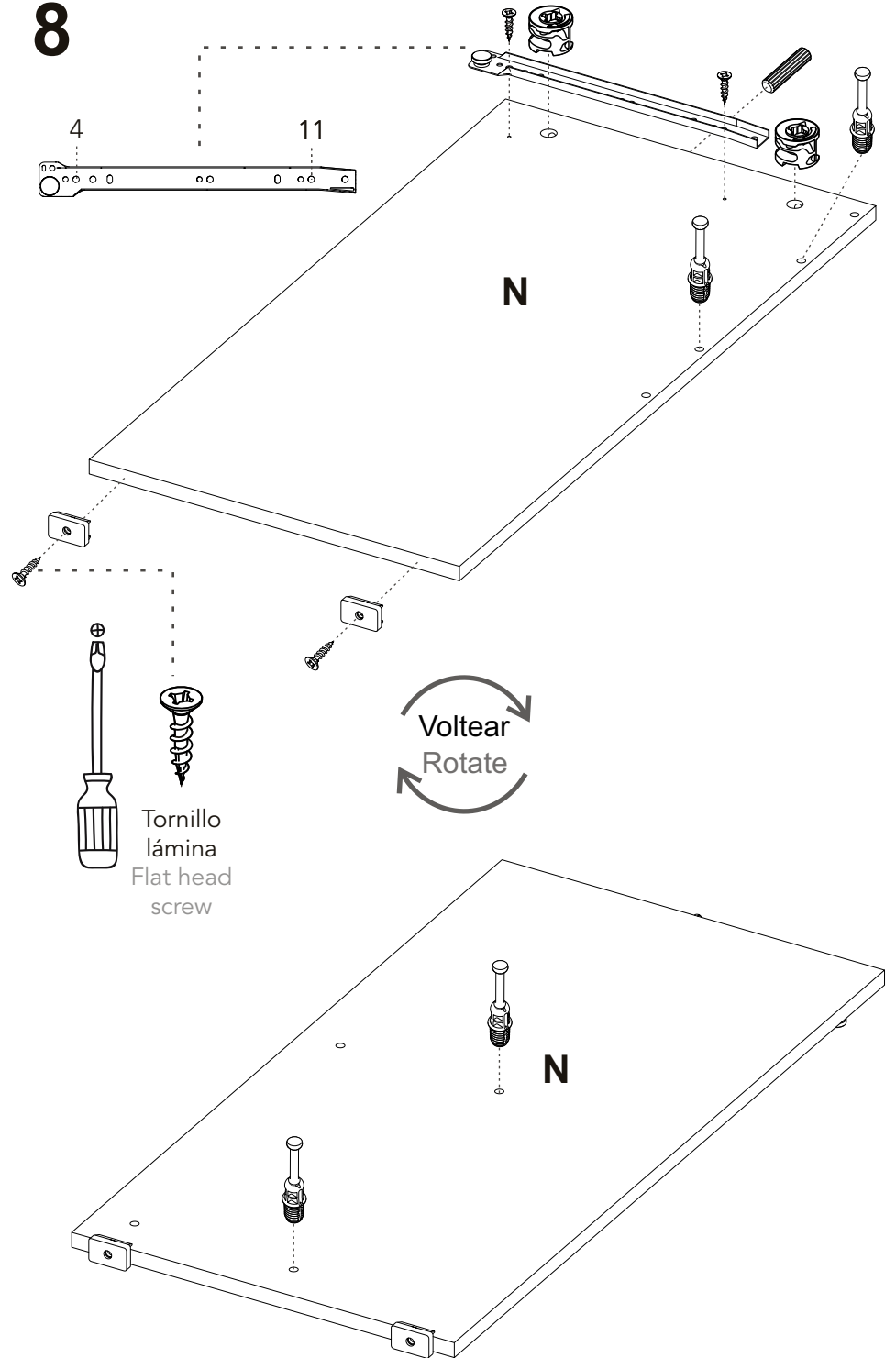

9

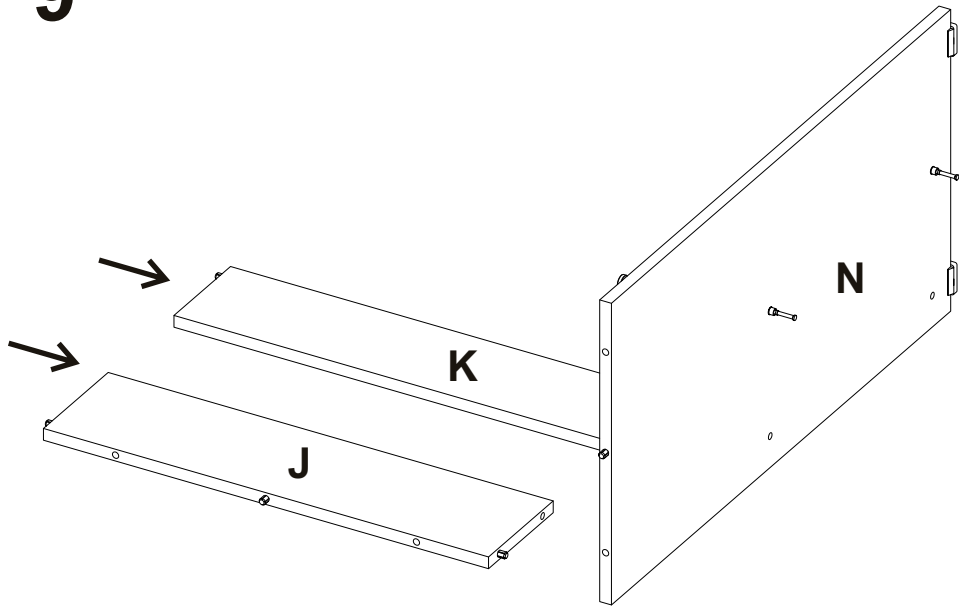

10

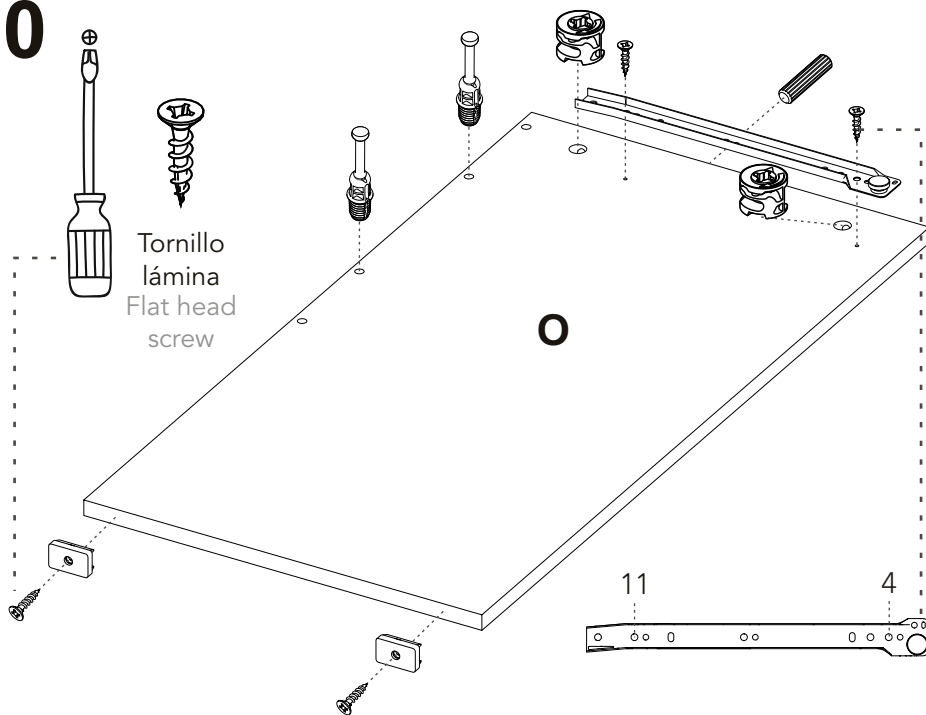

11

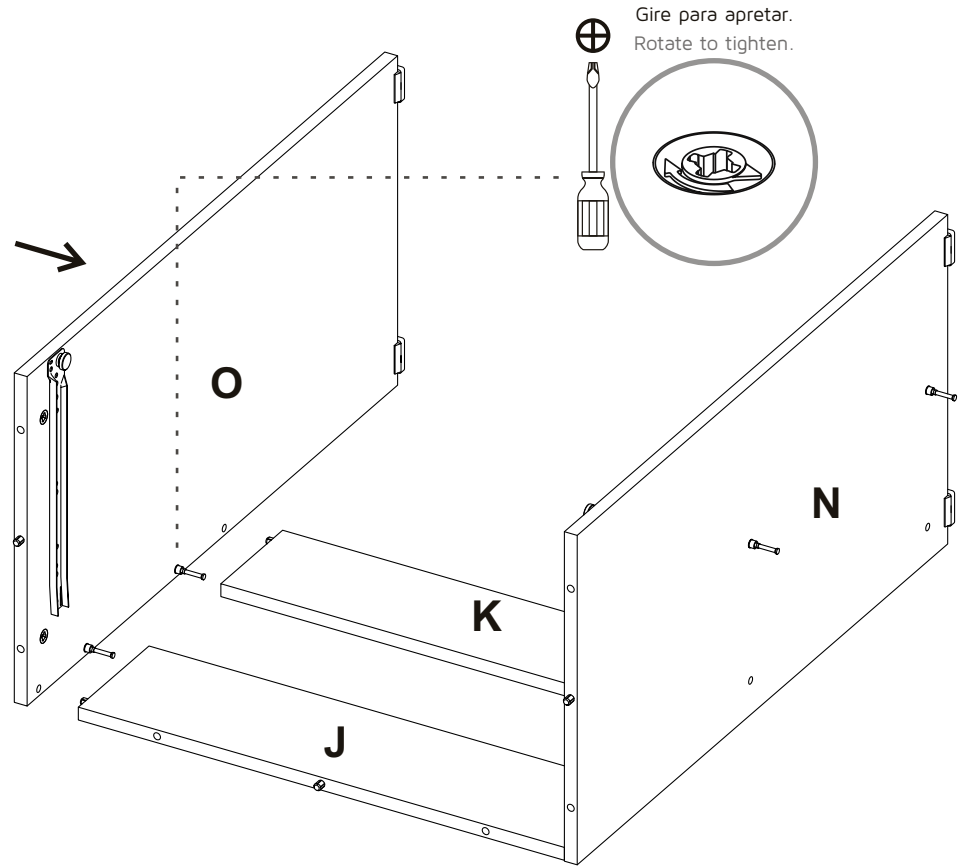

12

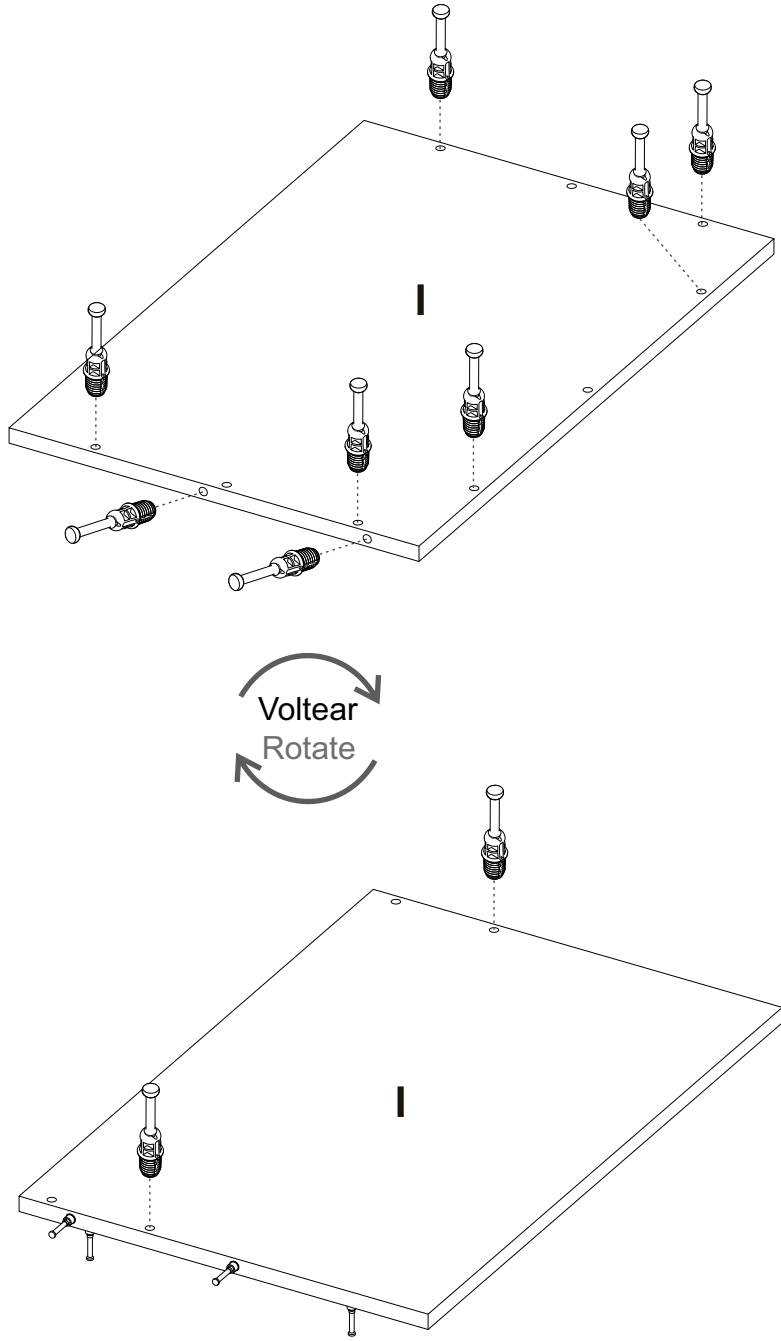

13

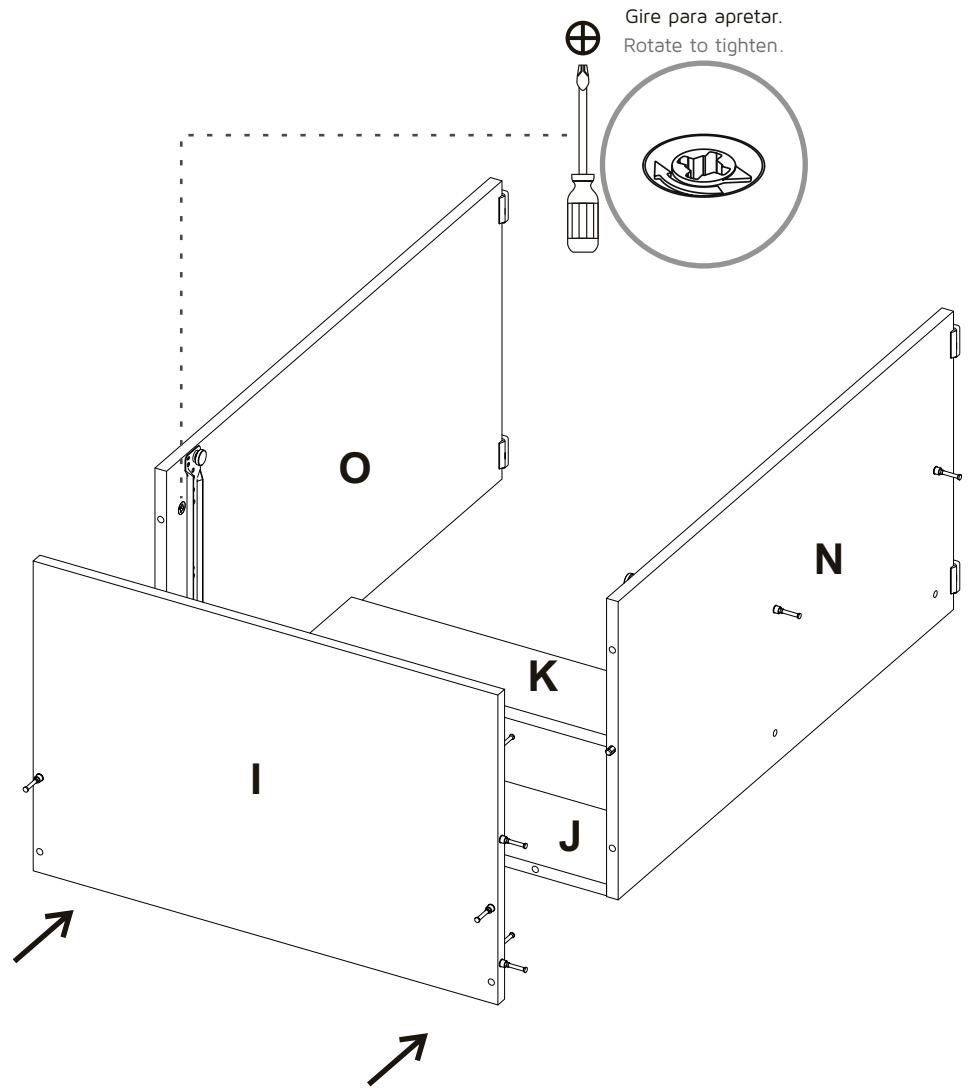

14

Se recomienda hacer
con 2 personas.
It is recommended to do
this with 2 people.

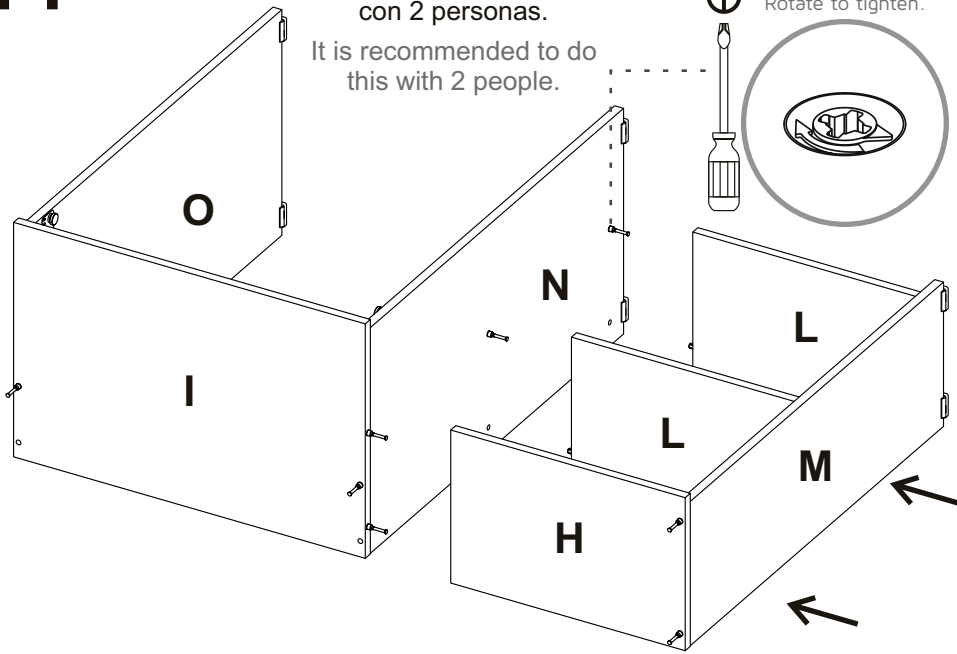
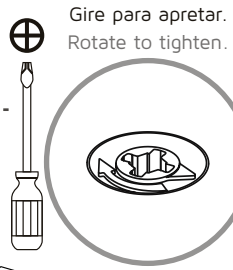

16

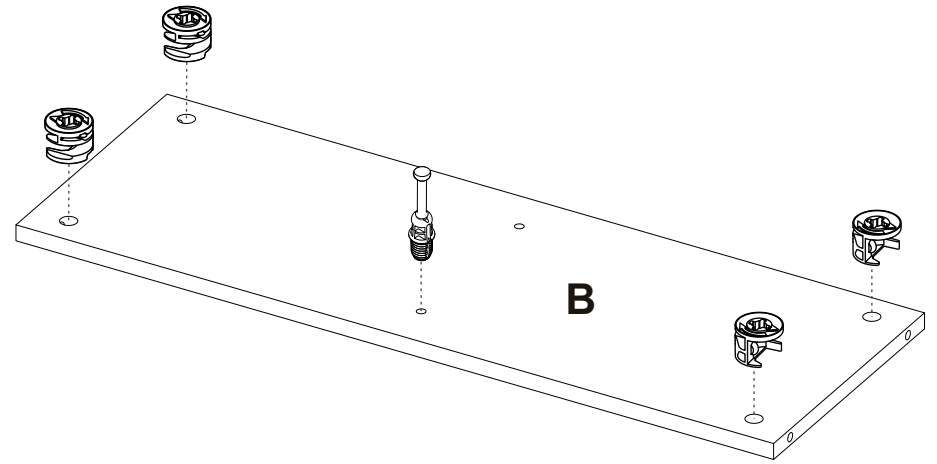

15

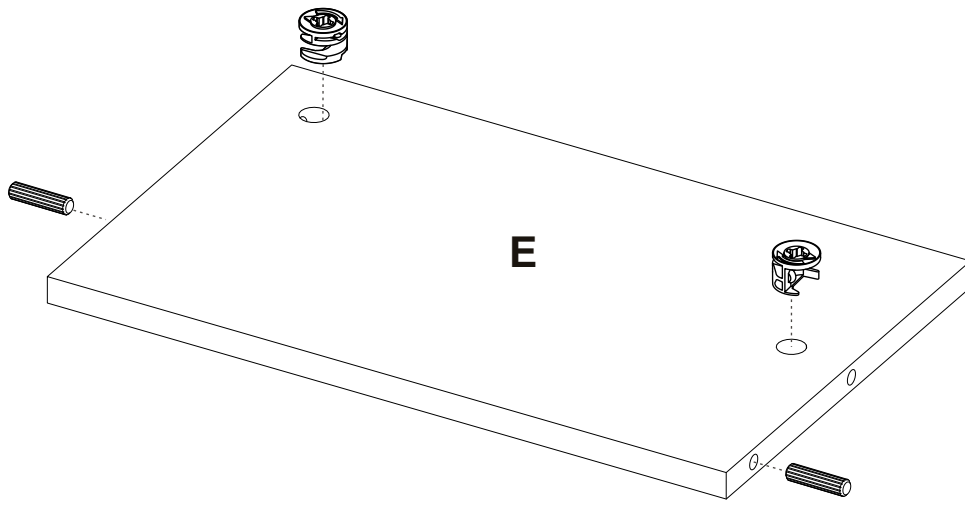

17

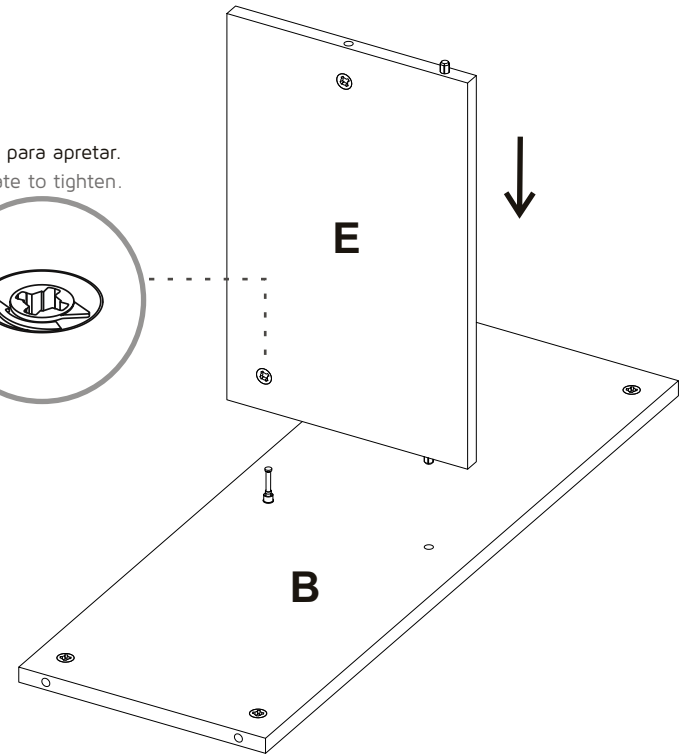
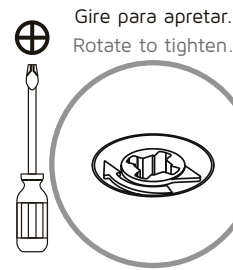

18

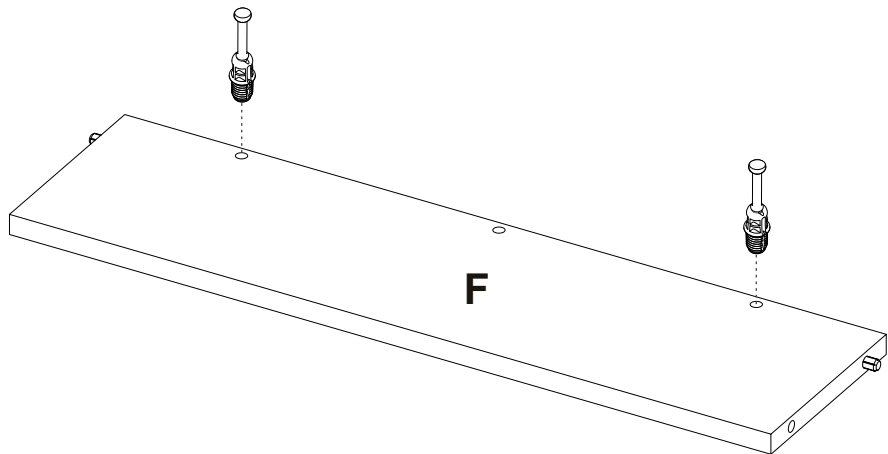
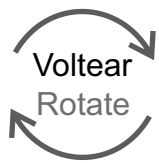
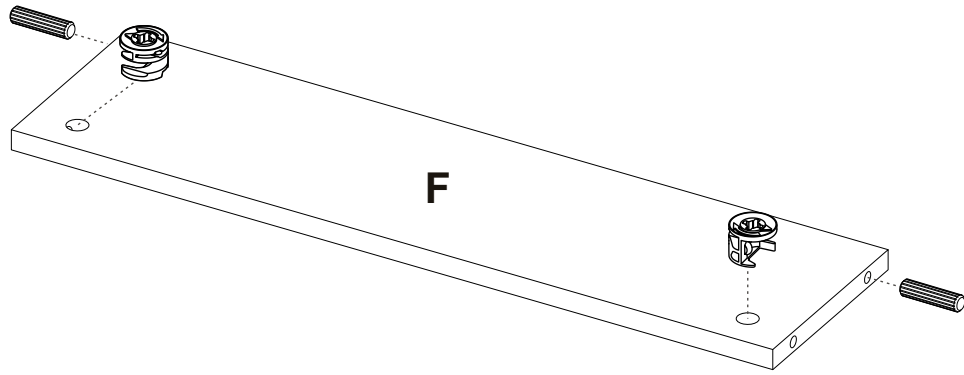

19

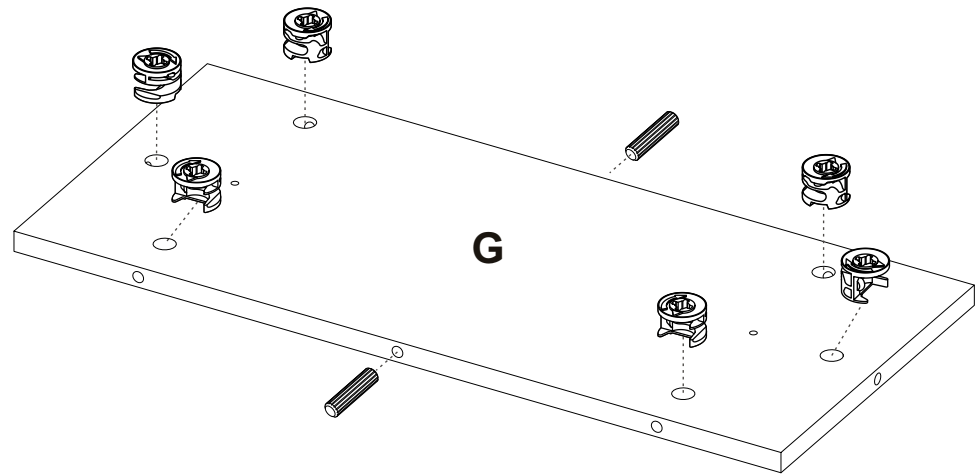

20

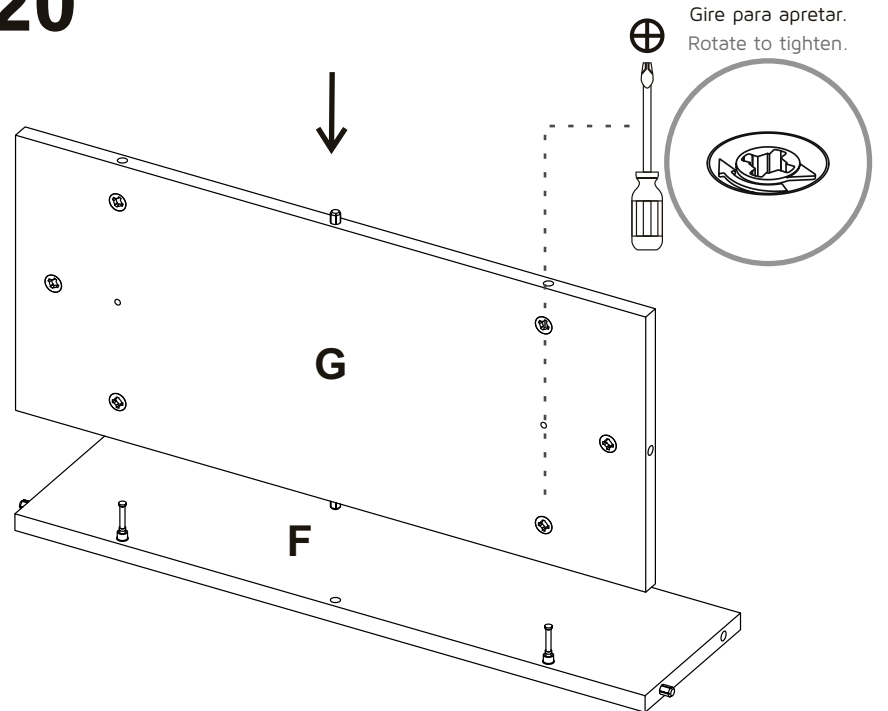

21

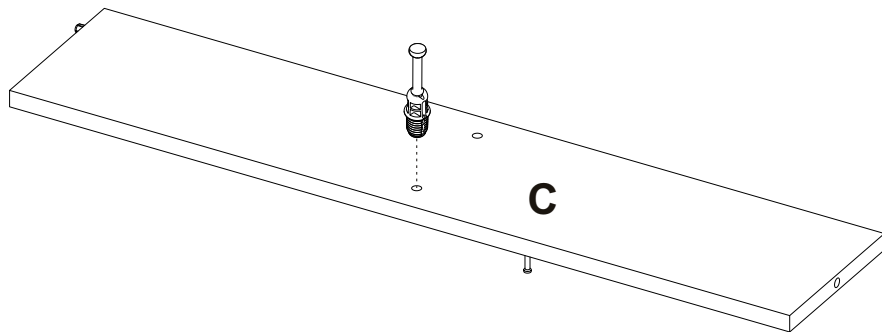
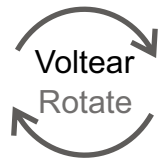
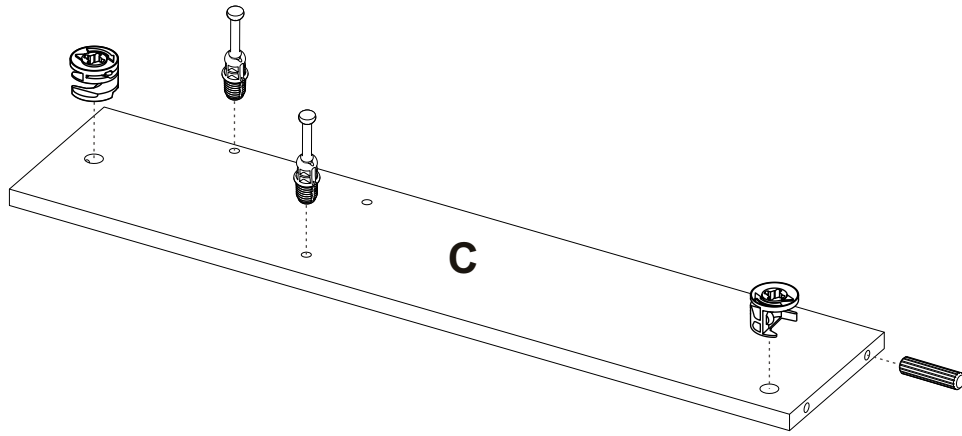

22

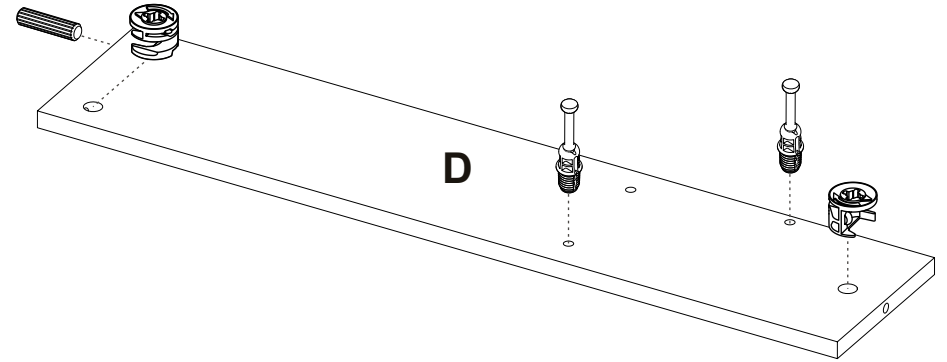

23

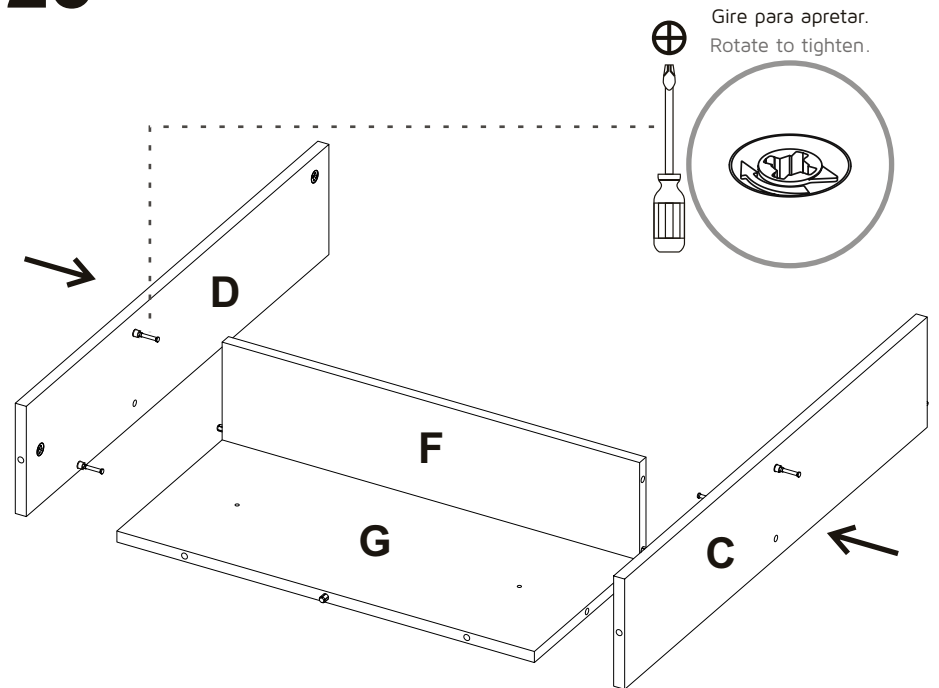

24

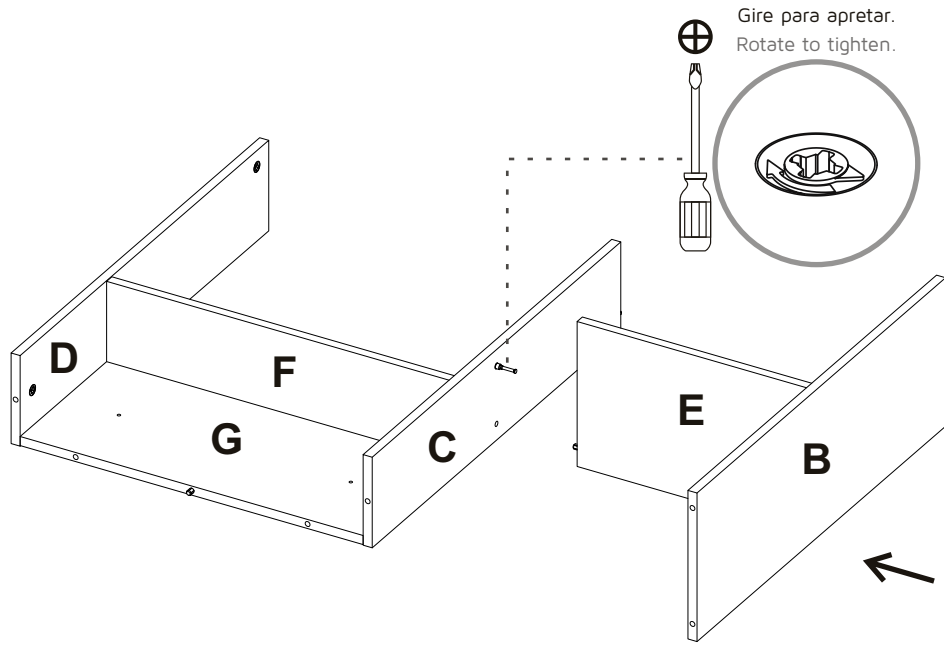

25

Se recomienda hacer con 2 personas.
It is recommended to do this with 2 people.

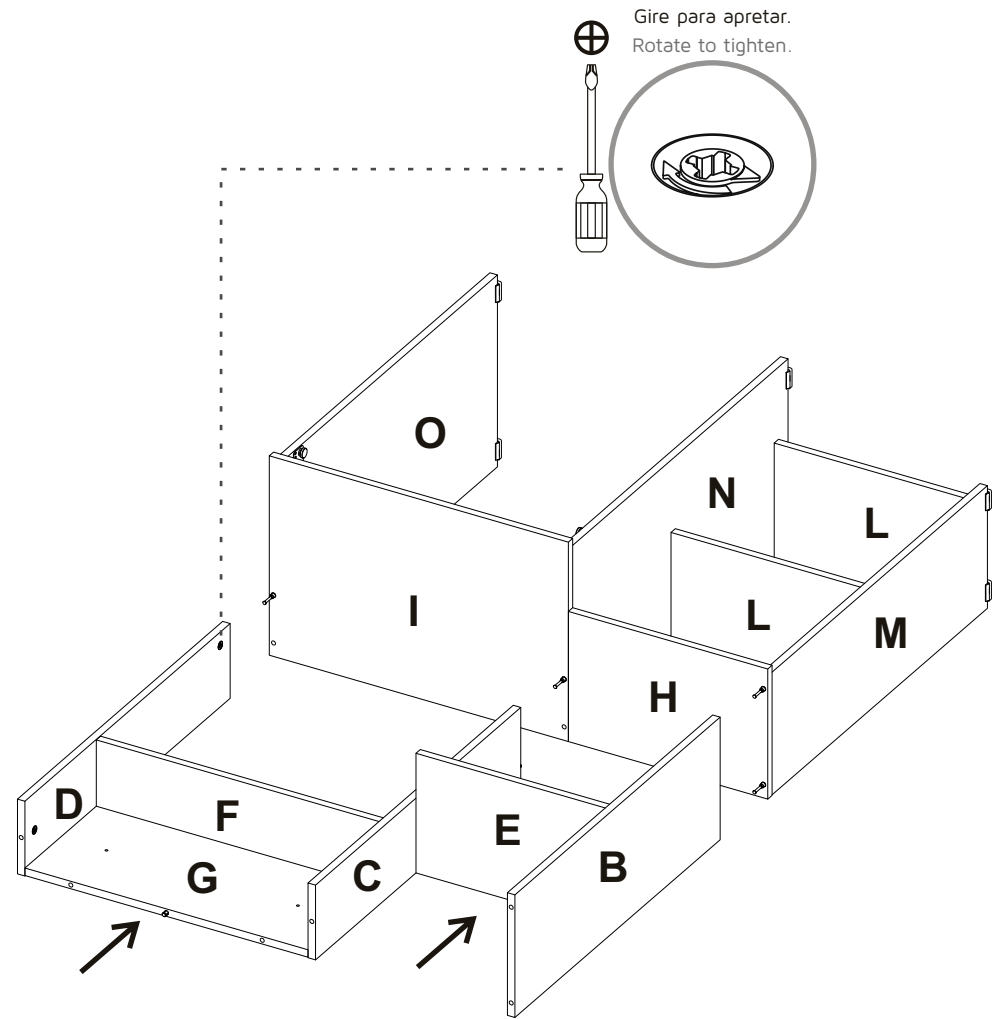

¡Con mucho cuidado!
very carefully!

26

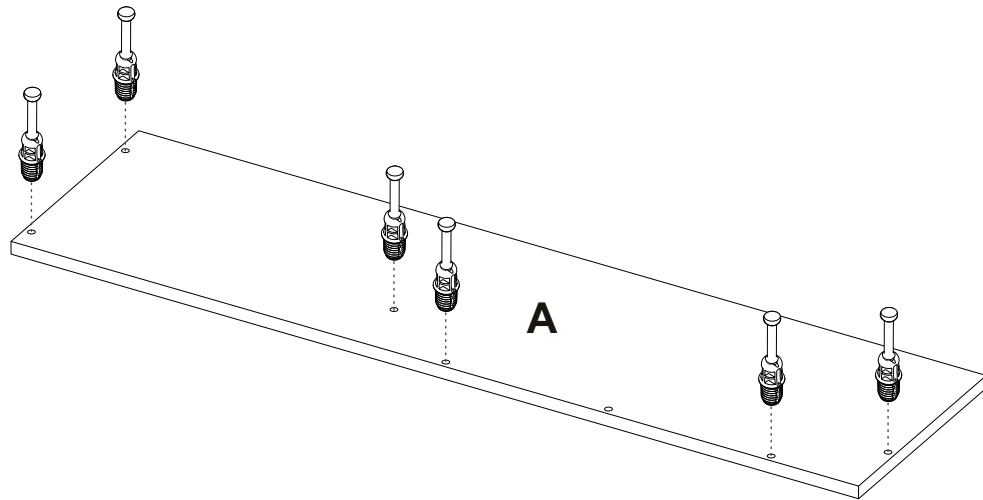



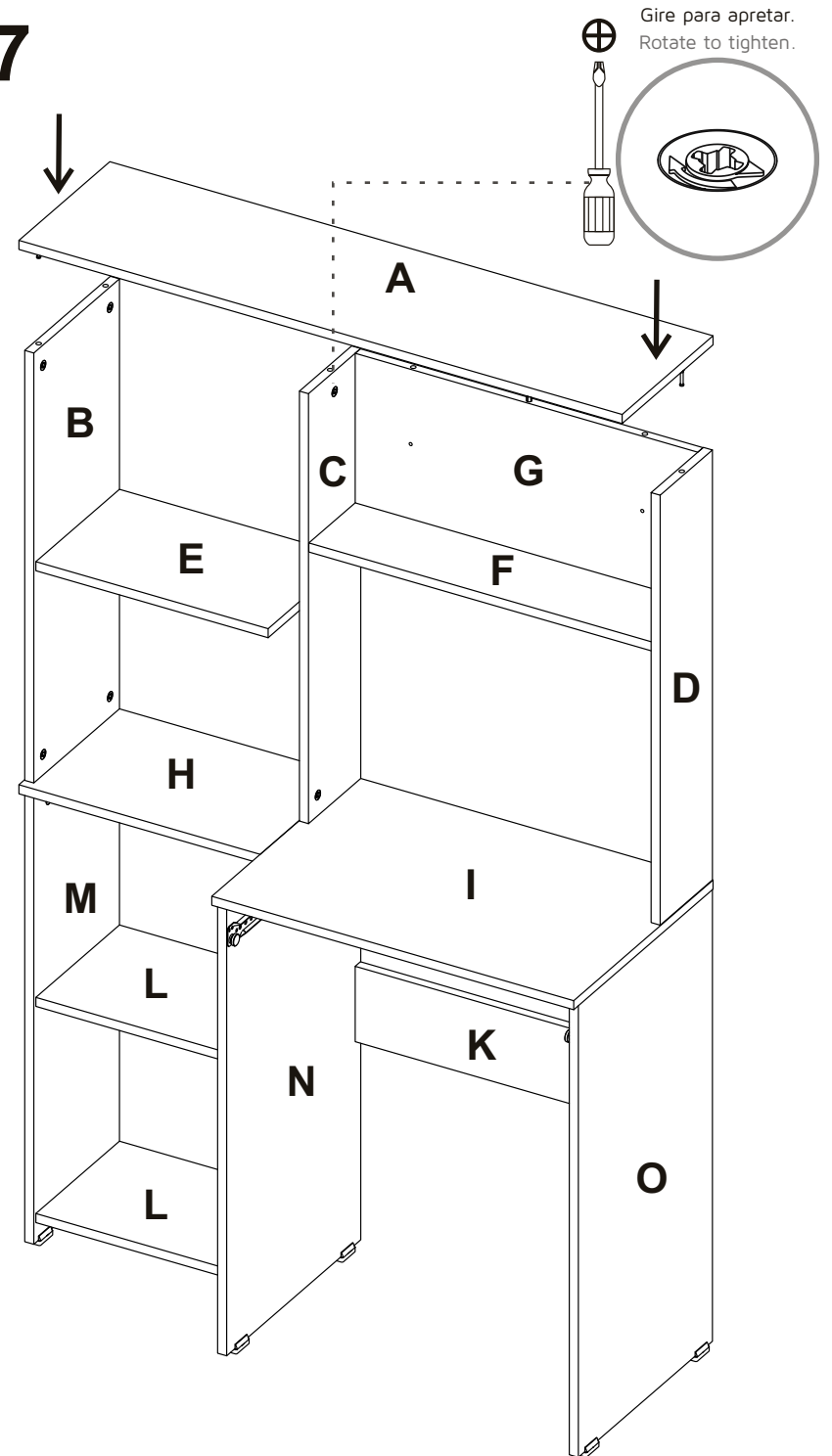

27

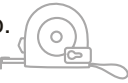

28

Fija el mueble a la pared Fix your cabinet to the wall

- 1 En la pared, mide y marca los puntos que te indicamos abajo.
On the wall, measure and mark the points shown below. 
- 2 Debes perforar en los puntos con taladro y una broca de 5/16".
Drill on the markings with a 5/16" drill bit. 
- 3 Inserta los chazos plásticos en las perforaciones.
Insert the wall anchors inside the drillings. 
- 4 Ubica el mueble y asegúralo con los tornillos.
Place the cabinet and secure it with the screws. 

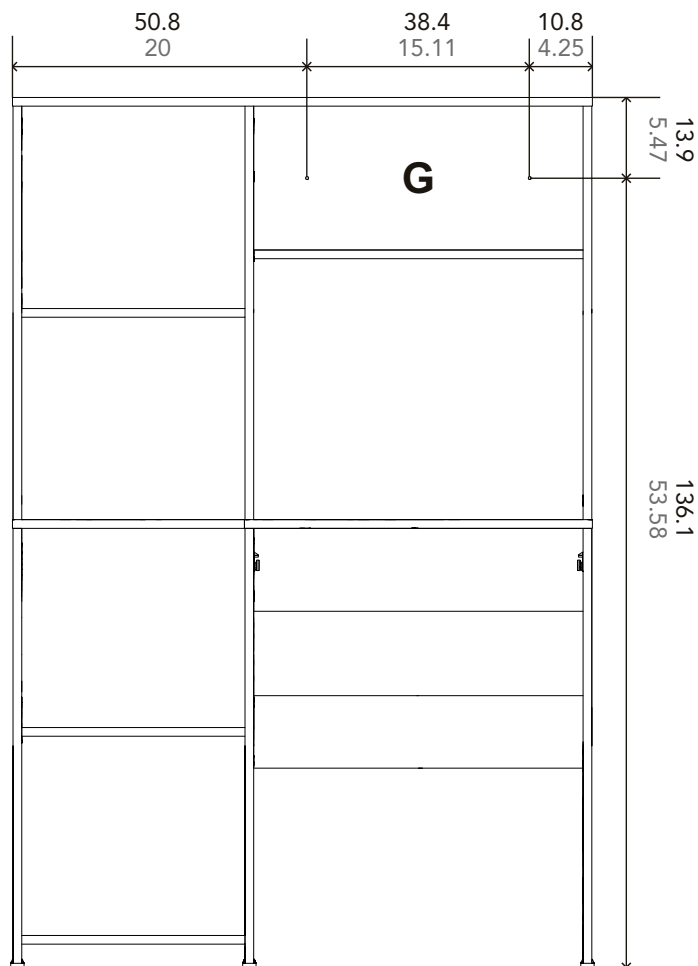

*Medidas en cm / Measurements in cm
*Medidas en pulgadas / Measurements in inches

29

La rueda del riel debe ir en la parte trasera del cajón.
The wheel should go on the rear part of the drawer.

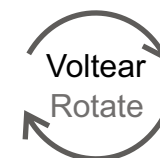
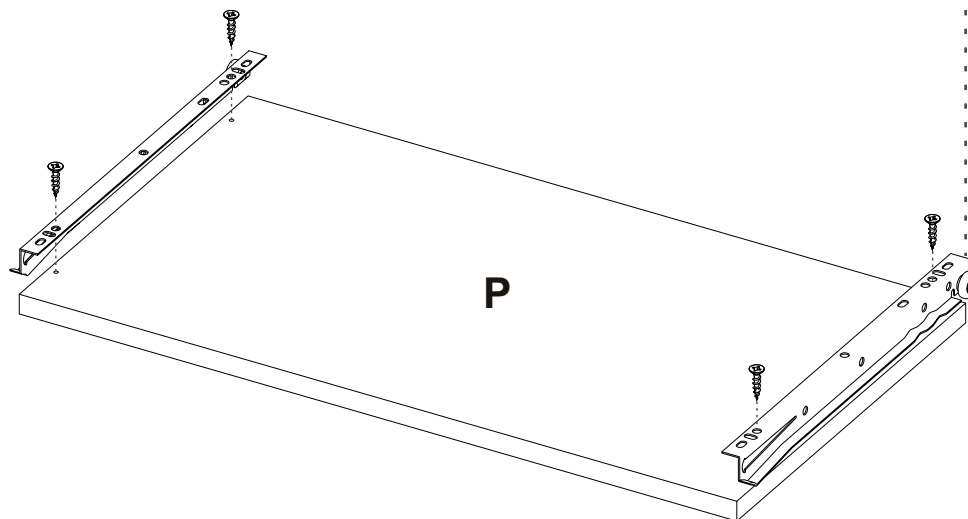
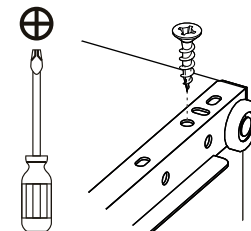

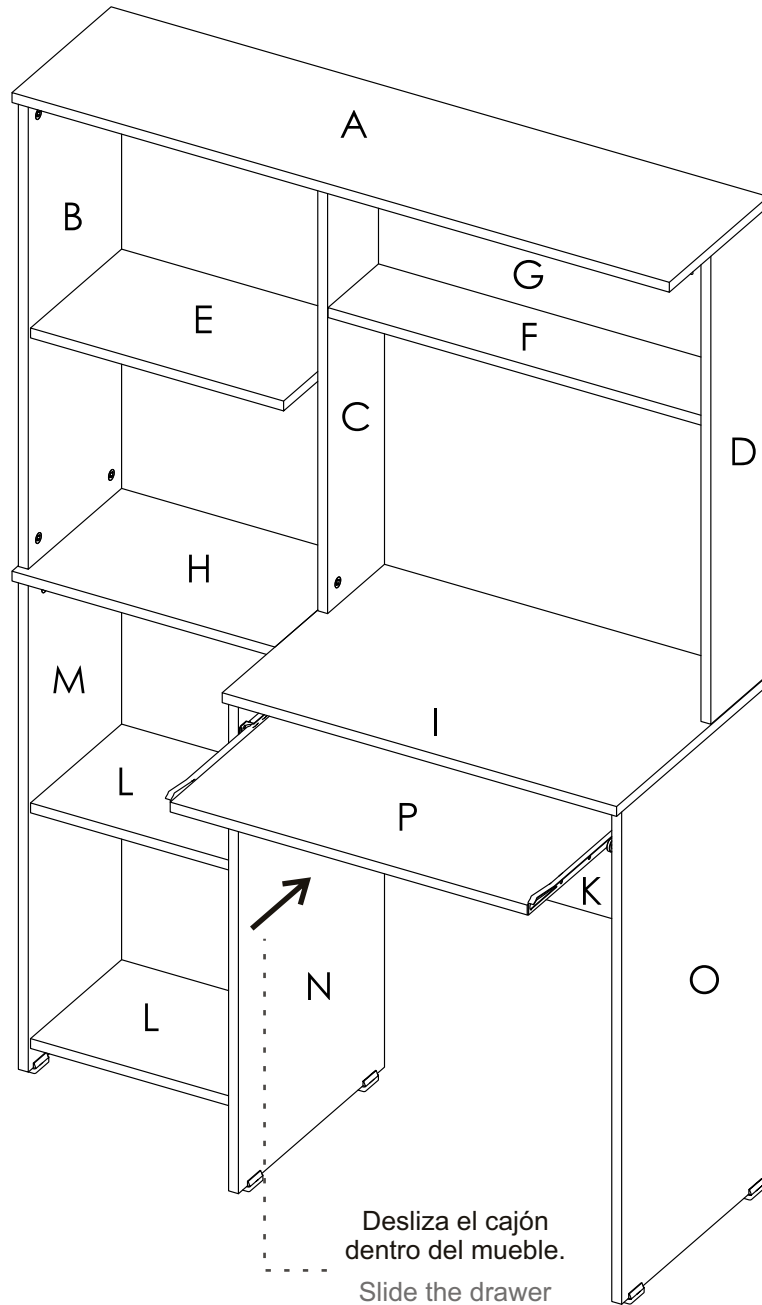

Desliza el cajón dentro del mueble.

Slide the drawer inside the cabinet.

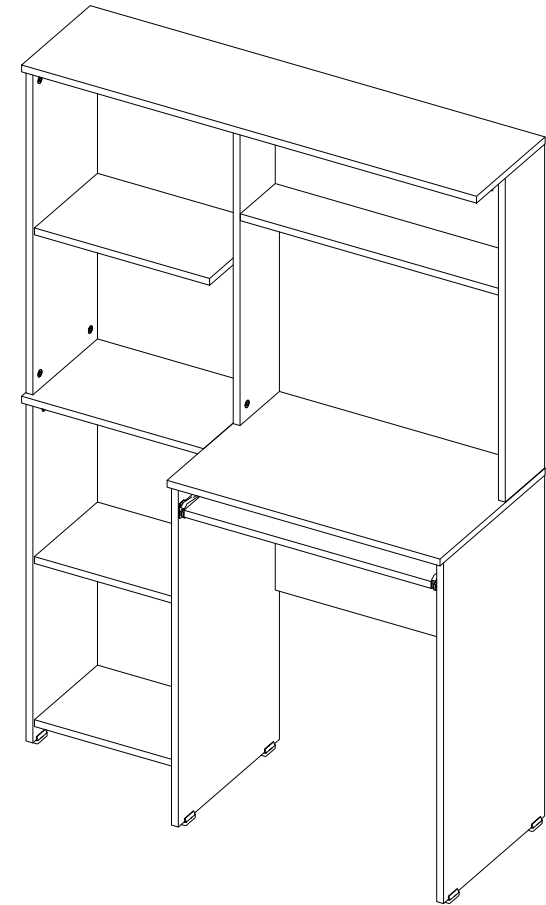

Para más información escanea AQUÍ/Scan for more info

Tapas minifix/
Cover caps



Después de ajustar todas las cajas minifix y los tornillos, cúbralas con las tapas adhesivas.
After you finish the adjustment of the cams and screws, cover them with the cover caps.



Al terminar de armar, desprenda las letras adhesivas.
After you finish assembling the cabinet, take off the adhesive letters.