

# INSTRUCCIONES DE ARMADO / ASSEMBLY INSTRUCTIONS

## MUEBLE PARA TV GLEN / GLEN TV STAND

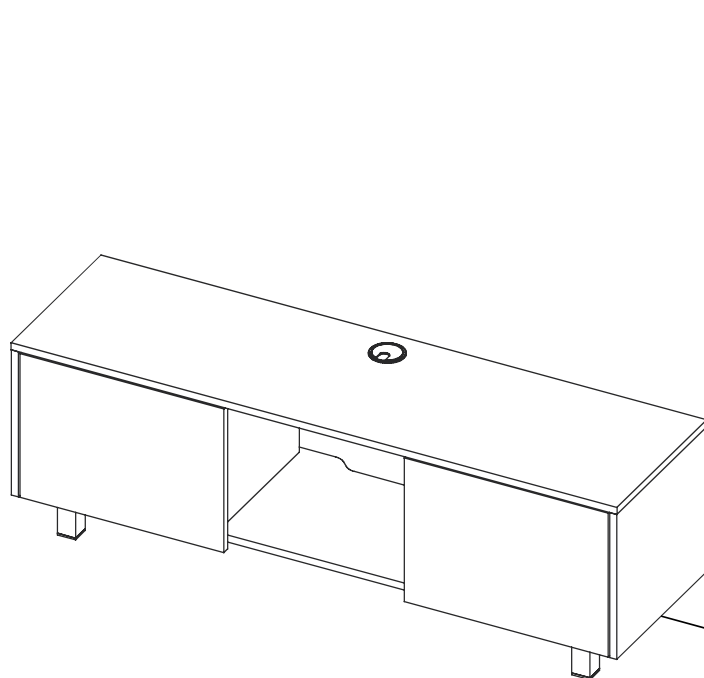

**MUEBLE A PISO**  
/ FURNITURE TO THE FLOOR

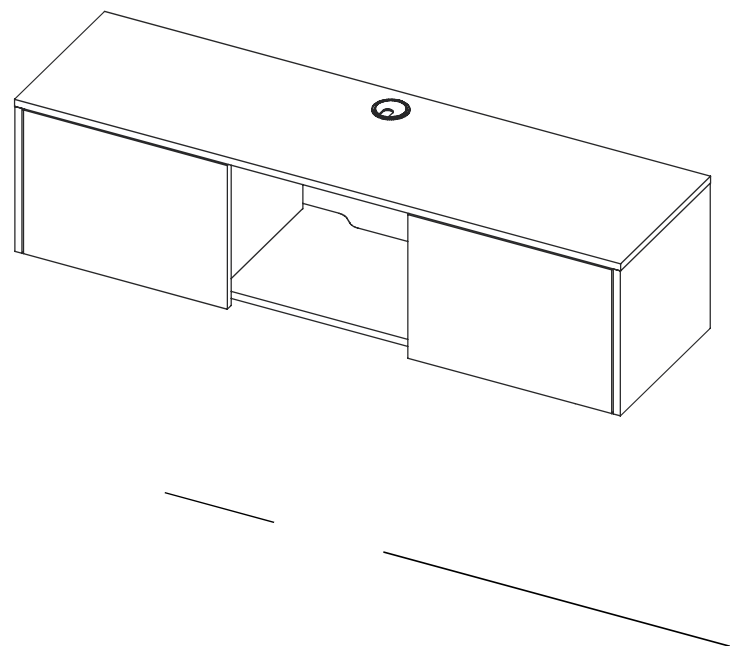

**MUEBLE A PARED**  
/ FURNITURE TO THE WALL

LOT N°

**RTA**<sup>®</sup>  
m u e b l e s

Tel: (602) 695 9581 / 695 91 81 | EXT 118  
La Nueva Estancia, Yumbo - Valle del Cauca - Colombia  
[www.rta.com.co](http://www.rta.com.co)

# ¡ATENCIÓN! / ATTENTION!

En las próximas páginas está el contenido de las piezas y herrajes del mueble. Asegúrate de que la cantidad de herrajes y piezas que hay en la caja sea la correcta y todo esté en buen estado. Ya que cuando el mueble esté armado no podrás realizar ninguna reposición.

On the next pages is the content of the pieces and hardware of the furniture. Make sure the number of hardware and parts in the box is correct and everything is in good condition. When the furniture is assembled you will not be able to make any replacement

## Recomendaciones Importantes / Key Recommendations

- Ensamble el mueble entre dos personas. / Assemble the cabinet between two people.
- Ensamble el mueble sobre una superficie plana y lisa, preferiblemente sobre un tapete o el cartón de la caja. / Assemble the cabinet on a flat smooth surface, preferably on a carpeted floor or the box carton.
- Se recomienda utilizar un destornillador eléctrico para facilitar el ensamble / It is recommended to use an electric screwdriver to facilitate assembly.

## Herramientas Necesarias / Required Tools

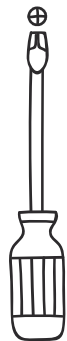

Destornillador de estrella  
Phillips Head  
Screwdriver



Destornillador de pala  
Flat Head  
Screwdriver

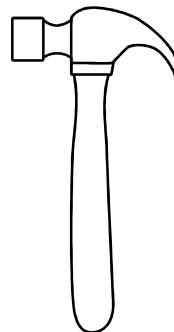

Martillo  
Hammer

## Herrajes Básicos / Basic Hardware

Aplica estas instrucciones cada vez que vayas a utilizar uno de estos herrajes durante el armado. / Apply these instructions everytime you're using one of these connectors during the assembly.

### Tarugos / Wood Dowels

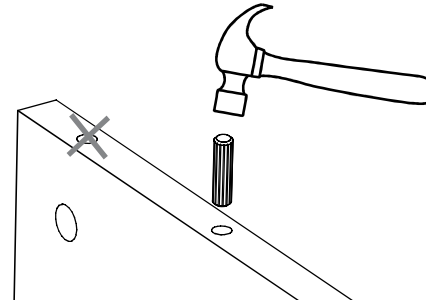

1. Inserta el tarugo en la perforación indicada y golpéalo suavemente hasta que llegue hasta el final de la perforación. / Put in the dowel inside the indicated hole and softly hit it until it's fully inside.
2. Verifica que NO se inserte el tarugo en la perforación de la caja minifix. / Verify that the dowel is NOT inserted into the perforation of the minifix cam.



Para más información  
escanea AQUÍ  
Scan for more info

### Minifix y Pernos / Minifix Cam & Spreading Bolt

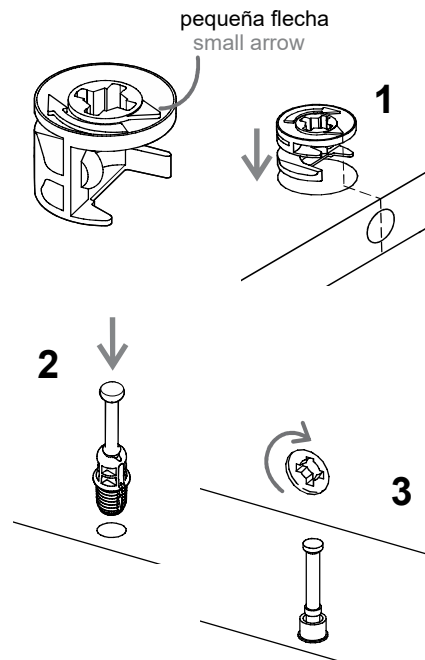





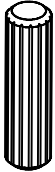
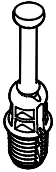

1. La caja minifix tiene una pequeña flecha en su parte superior, se debe insertar las cajas minifix con la flecha apuntando hacia la perforación que hay en el borde de la pieza. / The Minifix cam has a little arrow on its upper surface you should insert these cams with the little arrow pointing towards the drilling on the panel's edge.

2. Se debe insertar el perno con la parte plástica hacia abajo. / The spreading bolt should be put with the black plastic part facing down edge.

3. Luego de unir las piezas, se deben girar 180° las cajas minifix con un destornillador de estrella para ajustar y asegurar el ensamble. / After joining two panels together you should turn the cams 180° with a phillips head screwdriver to adjust and secure the joint.

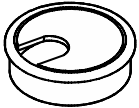
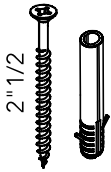
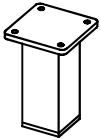
## Herrajes / Hardware

|   |   |   |   |
|---|---|---|---|
|  |  |            |  |
| Tarugo /<br>Wood dowel  | Perno Minifix /<br>Spreading Bolt   | Caja Minifix /<br>Minifix Cam   | Tapa Minifix /<br>Cover Caps  |
| x12   | x21   | x21   | x24   |
|  |  | <br>2" 1/2 |  |
| Bisagra interior<br>+ tornillos /<br>Inset overlay<br>hinge + screws              | Pasacables /<br>Desk<br>Grommet   | Chazo + Tornillo/<br>Wall anchor<br>+ screw   | Pata de<br>Aluminio /<br>Aluminium<br>Leg   |
| x4  | x1  | x3  | x5  |
|  |   |   |   |
| Tornillo<br>lámina /<br>Flat head<br>screw  |   |   |   |
| x20   |   |   |   |

## Cargas Máximas / Max Suggested Loads

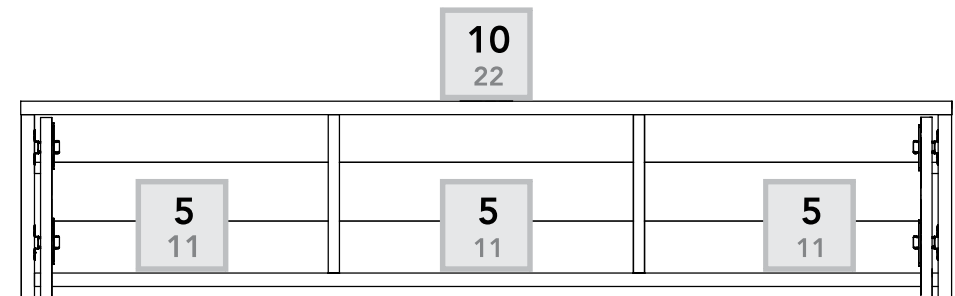
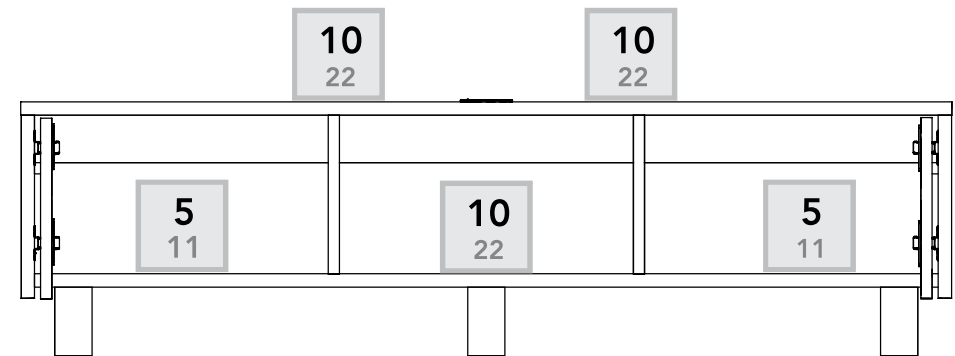

\*Peso en Kg / Weight in Kg.

\*Peso en Libras / Weight in Lb

# Piezas de Armado / Assembly Parts

|        |
|--------|
| A - x1 |
| B - x1 |
| C - x1 |
| D - x1 |
| E - x2 |
| F - x1 |
| G - x1 |
| H - x1 |
| I - x1 |

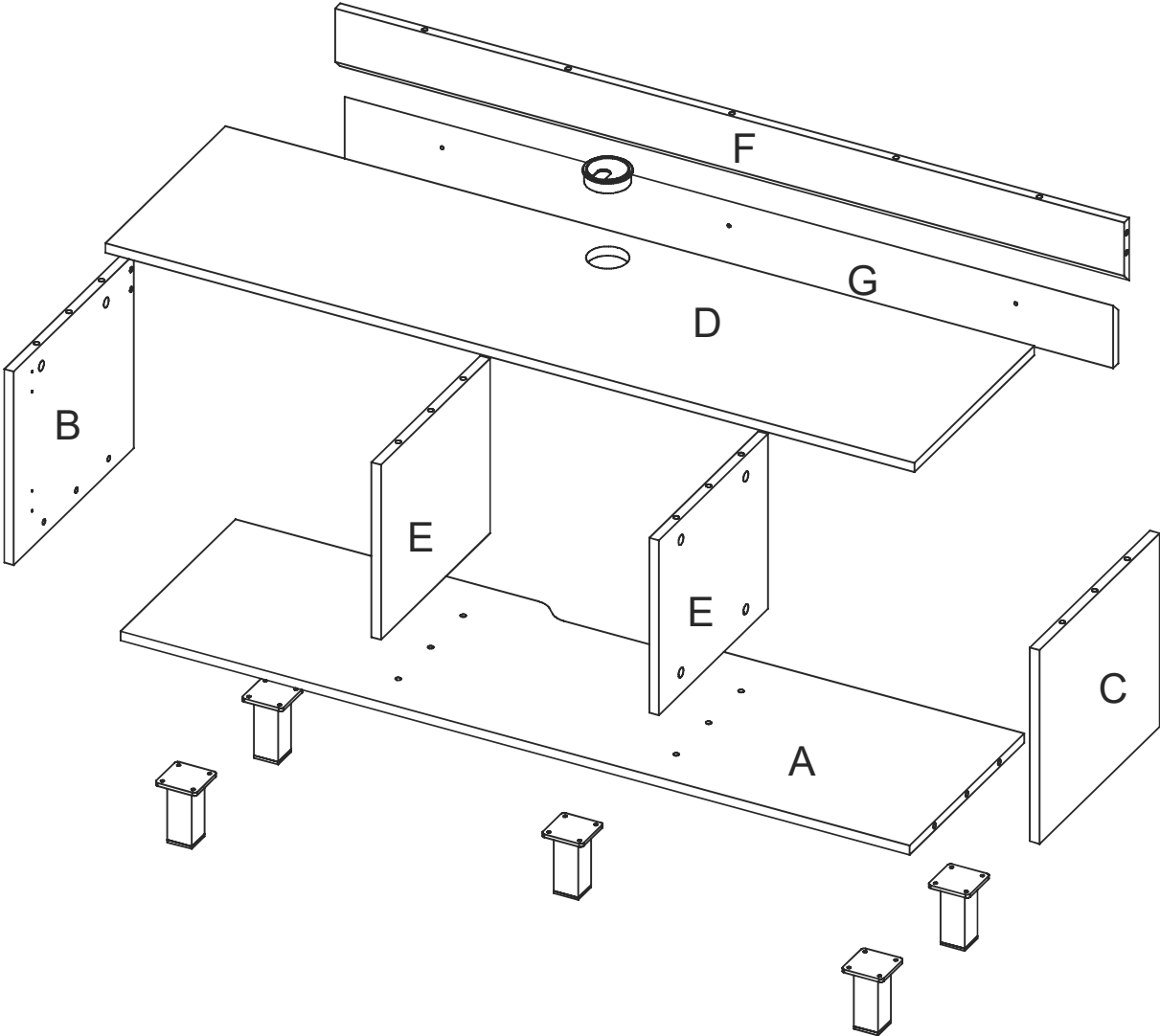
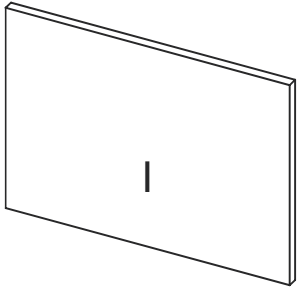
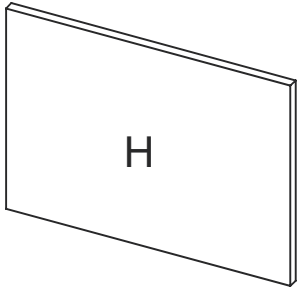

# 1

EN CASO DE QUE DESEE COLGAR EL MUEBLE A LA PARED, OMITA LA INSTALACIÓN DE LAS PATAS EN ESTE PASO.

IF YOU WISH TO HANG THE FURNITURE ON THE WALL, SKIP THE INSTALLATION OF THE LEGS AT THIS STEP.

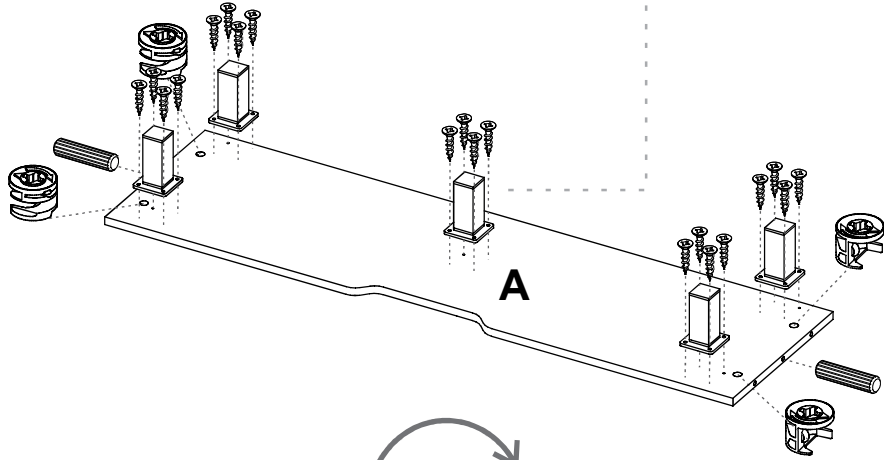

Voltar  
Rotate

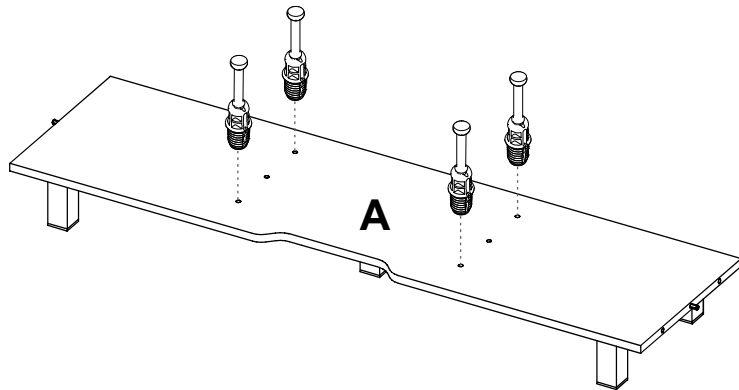

# 2

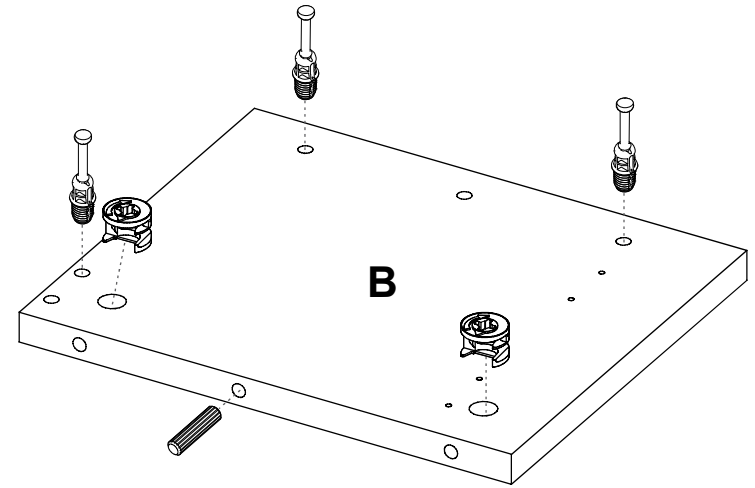

# 3

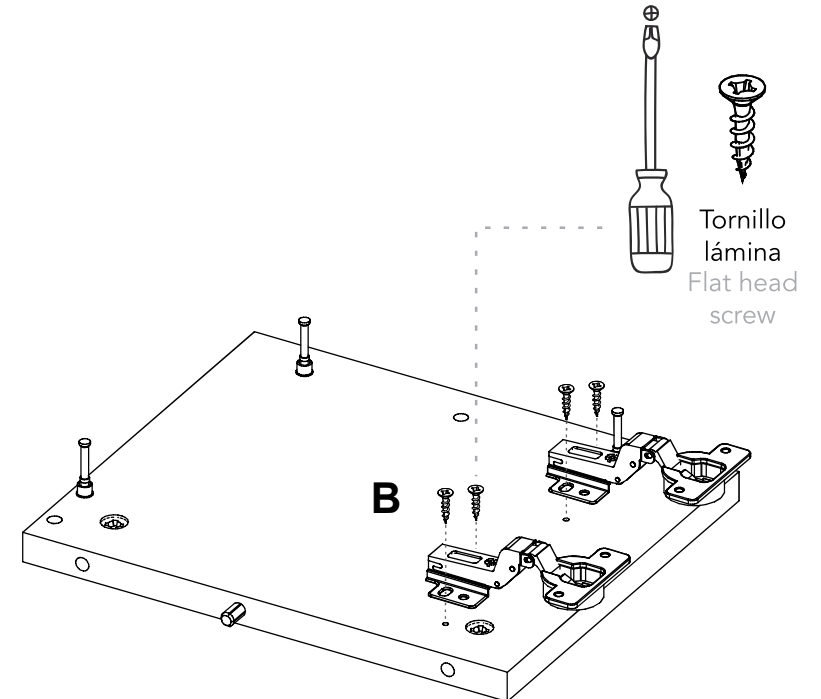

4

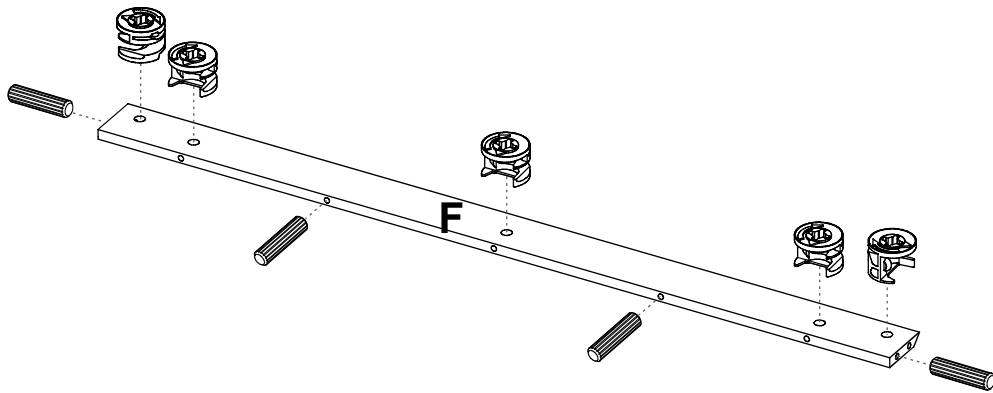

6

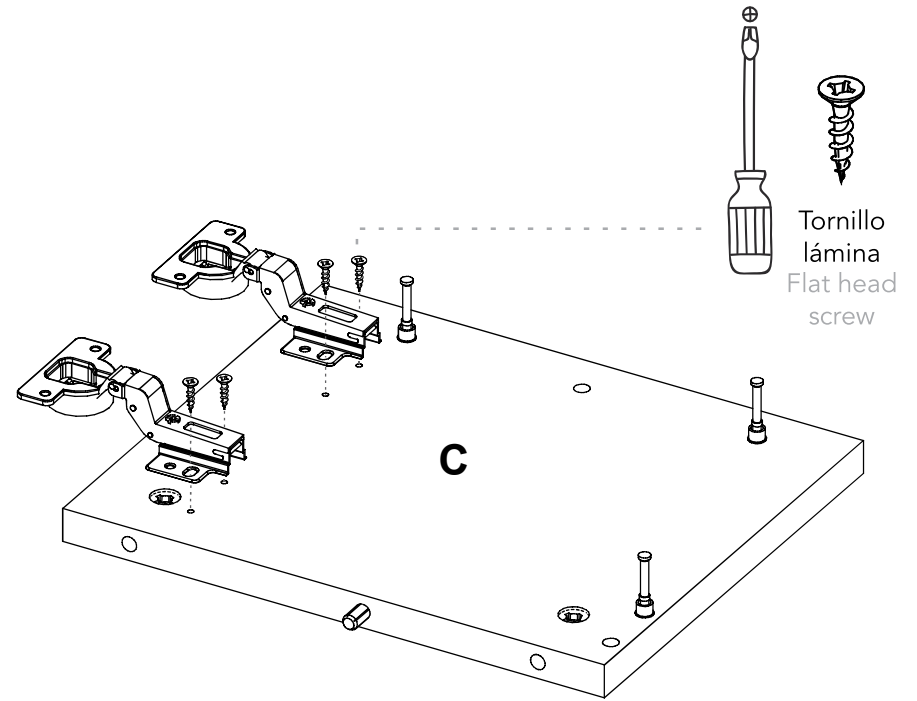

5

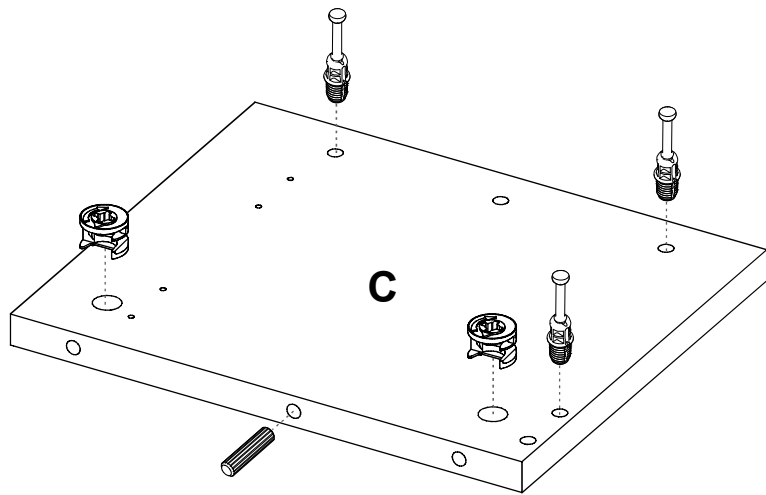

7

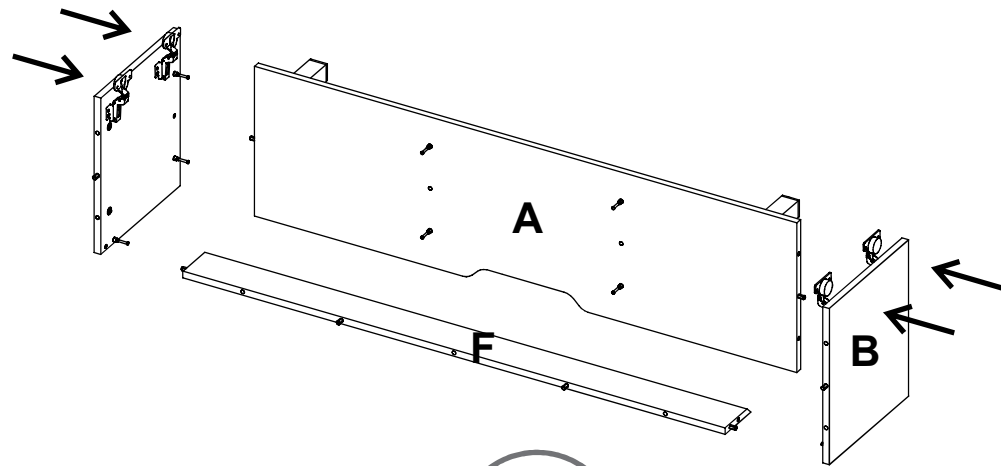

Voltea el mueble  
Turn over the cabinet

¡Con mucho cuidado!  
very carefully!

8

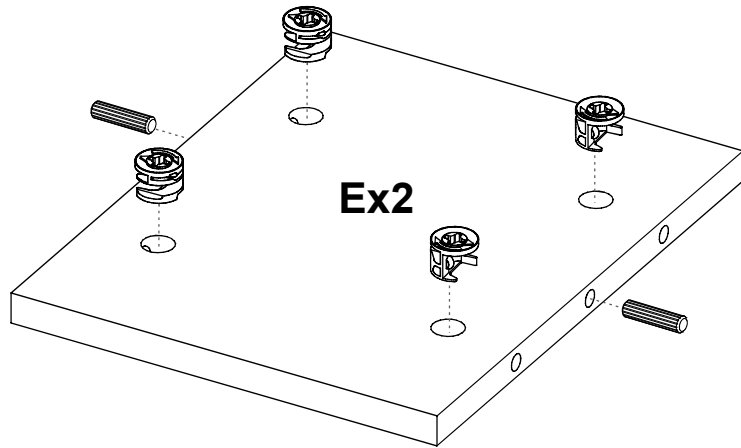

10

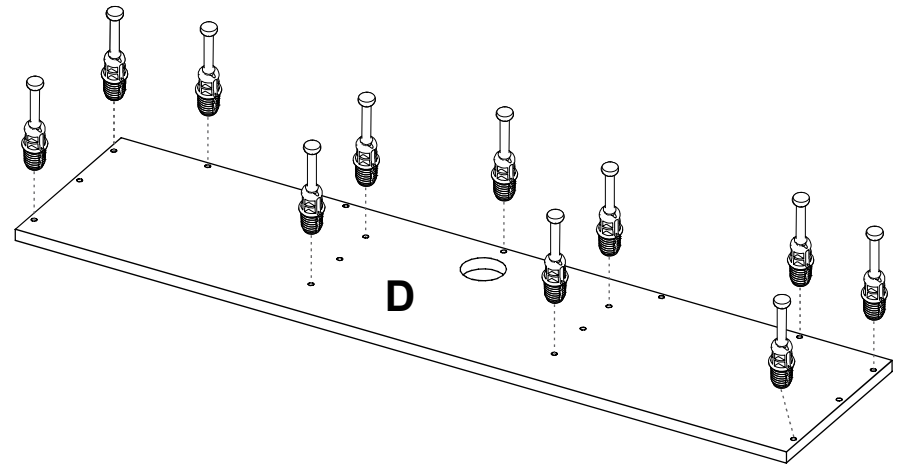

9

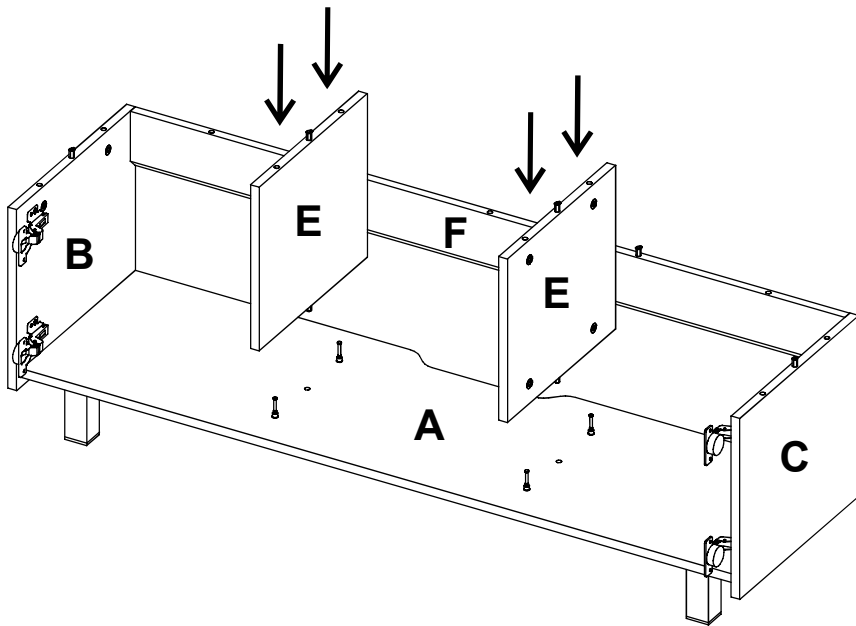

11

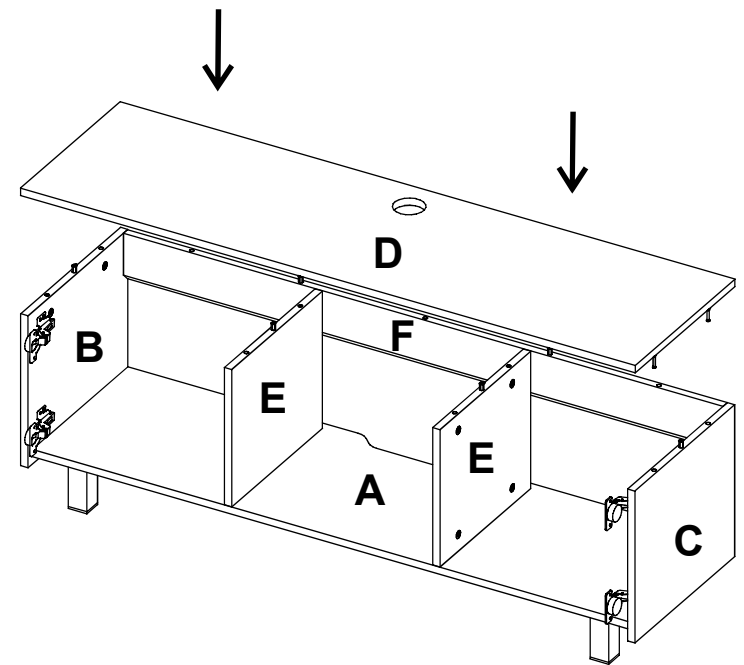

# 12

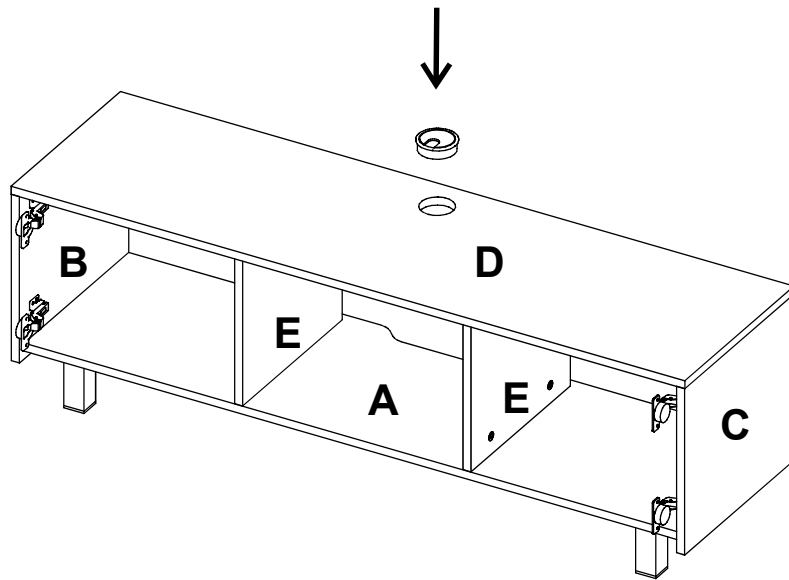

# 13

Para fijar el mueble a pared utiliza la pieza G, siguiendo las instrucciones que se presentan a continuación. En caso de que las patas se hayan instalado, omitir este paso.

To secure the furniture to the wall, use part G, following the instructions provided below. If the legs have been installed, skip this step.

1 En la pared, mide y marca los puntos que te indicamos abajo.  
On the wall, measure and mark the points shown below.



2 Debes perforar en los puntos con taladro y una broca de 5/16"  
Drill on the markings with a 5/16" drill bit.



3 Inserta los chazos plásticos en las perforaciones.  
Insert the wall anchors inside the drillings.



4 Ubica el mueble y asegúralo con los tornillos.  
Place the cabinet and secure it with the screws.

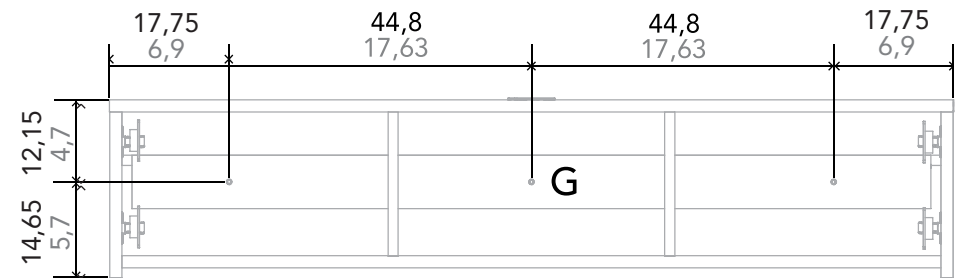

\*Distancia definida por el usuario

\*User defined distance

Piso  
Floor

\*Medidas en cm / Measurements in cm  
\*Medidas en pulgadas / Measurements in inches

# 14

## Instalación de la puerta Door Installation

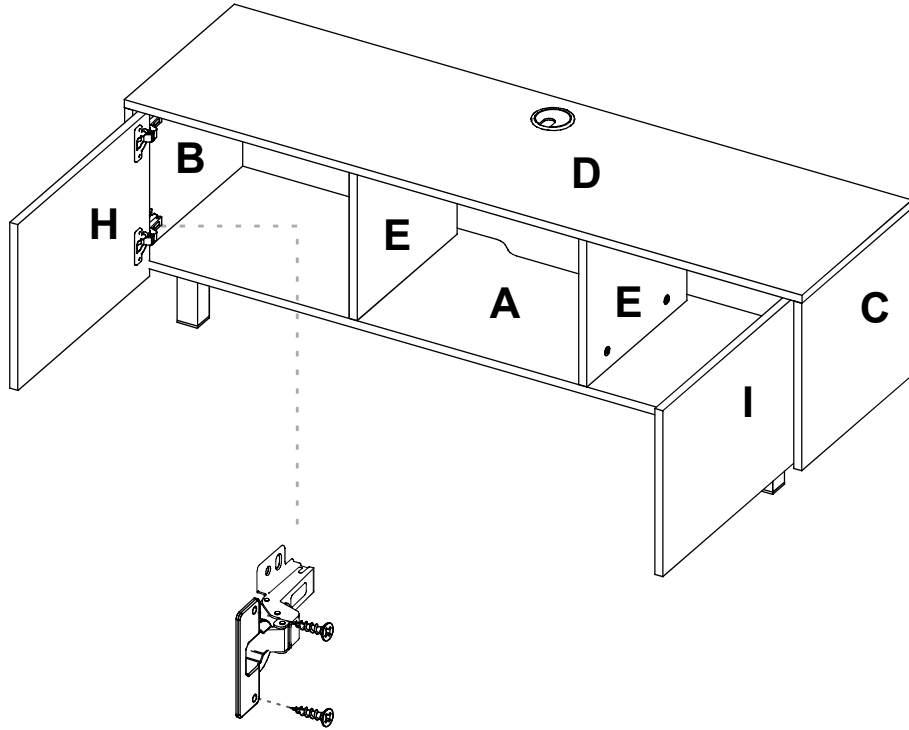

Seguir las instrucciones de ajuste de la siguiente pagina. →  
Follow the adjustment instructions on the next page.

# 15

## Ajuste de las bisagras Hinge adjustment

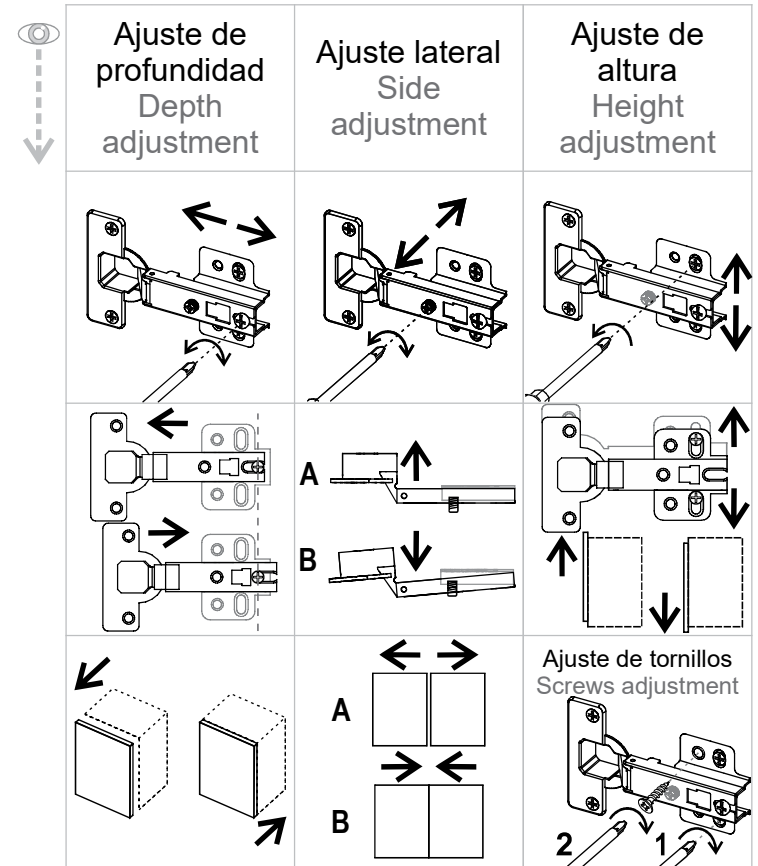

Usar los ajustes según la necesidad específica.  
Use the settings according to the specific need.

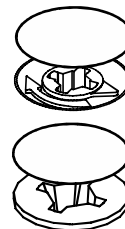

Después de ajustar todas las cajas minifix y los tornillos, cúbralas con las tapas adhesivas.  
After you finish the adjustment of the cams and screws, cover them with the cover caps.



Al terminar de armar, desprenda las letras adhesivas.  
After you finish assembling the cabinet, take off the adhesive letters.