

**INSTRUCCIONES DE ARMADO / ASSEMBLY INSTRUCTIONS**  
**MUEBLE DE ENTRETENIMIENTO SMITH 75" / ENTERTAINMENT FURNITURE**  
**SMITH 75"**

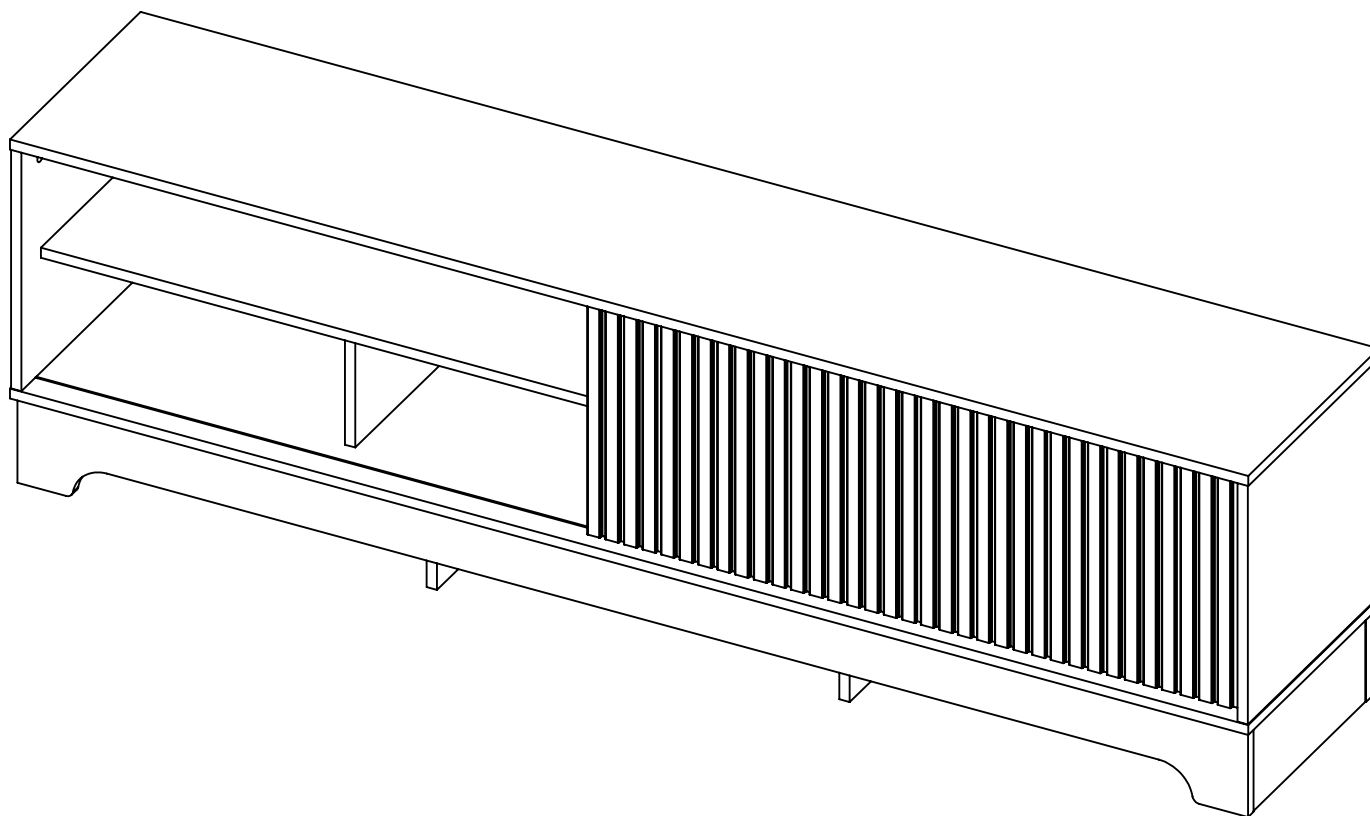

LOT N°

**RTA**<sup>®</sup>  
m u e b l e s

Tel: (602) 695 9581 / 695 91 81 | EXT 118  
La Nueva Estancia, Yumbo - Valle del Cauca - Colombia  
[www.rta.com.co](http://www.rta.com.co)

# ¡ATENCIÓN! / ATTENTION!

En las próximas páginas está el contenido de las piezas y herrajes del mueble. Asegúrate de que la cantidad de herrajes y piezas que hay en la caja sea la correcta y todo esté en buen estado. Ya que cuando el mueble esté armado no podrás realizar ninguna reposición.

On the next pages is the content of the pieces and hardware of the furniture. Make sure the number of hardware and parts in the box is correct and everything is in good condition. When the furniture is assembled you will not be able to make any replacement

## Recomendaciones Importantes / Key Recommendations

- Ensamble el mueble entre dos personas. / Assemble the cabinet between two people.
- Ensamble el mueble sobre una superficie plana y lisa, preferiblemente sobre un tapete o el cartón de la caja. / Assemble the cabinet on a flat smooth surface, preferably on a carpeted floor or the box carton.
- Se recomienda utilizar un destornillador eléctrico para facilitar el ensamble / It is recommended to use an electric screwdriver to facilitate assembly.

## Herramientas Necesarias / Required Tools



Destornillador de estrella  
Phillips Head  
Screwdriver



Destornillador de pala  
Flat Head  
Screwdriver

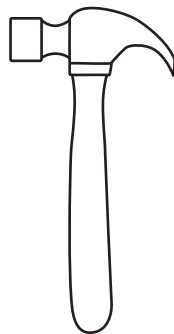

Martillo  
Hammer

## Herrajes Básicos / Basic Hardware

Aplica estas instrucciones cada vez que vayas a utilizar uno de estos herrajes durante el armado. / Apply these instructions everytime you're using one of these connectors during the assembly.

### Tarugos / Wood Dowels

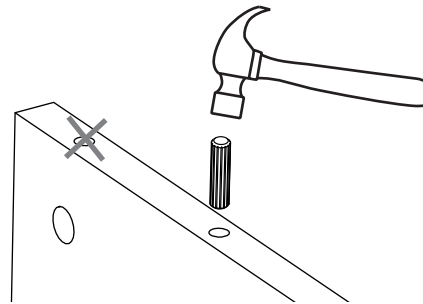

1. Inserta el tarugo en la perforación indicada y golpéalo suavemente hasta que llegue hasta el final de la perforación. / Put in the dowel inside the indicated hole and softly hit it until it's fully inside.
2. Verifica que NO se inserte el tarugo en la perforación de la caja minifix. / Verify that the dowel is NOT inserted into the perforation of the minifix cam.







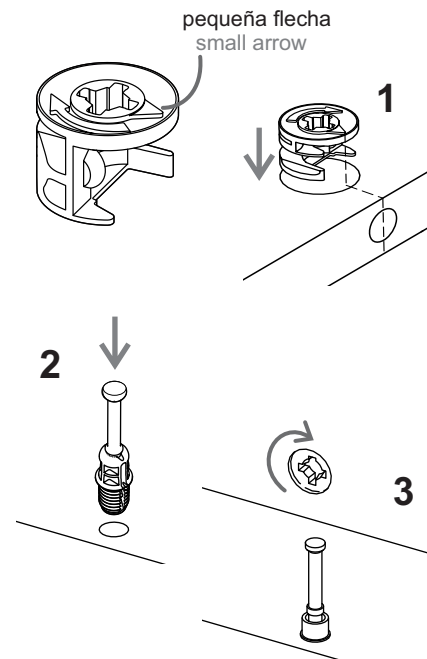





Para más información  
escanea AQUÍ  
Scan for more info

### Minifix y Pernos / Minifix Cam & Spreading Bolt

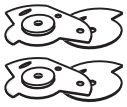

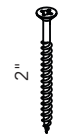
1. La caja minifix tiene una pequeña flecha en su parte superior, se debe insertar las cajas minifix con la flecha apuntando hacia la perforación que hay en el borde de la pieza. / The Minifix cam has a little arrow on its upper surface you should insert these cams with the little arrow pointing towards the drilling on the panel's edge.
2. Se debe insertar el perno con la parte plástica hacia abajo. / The spreading bolt should be put with the black plastic part facing down edge.
3. Luego de unir las piezas, se deben girar 180° las cajas minifix con un destornillador de estrella para ajustar y asegurar el ensamble. / After joining two panels together you should turn the cams 180° with a phillips head screwdriver to adjust and secure the joint.

## Herrajes / Hardware

 <p>Tarugo Wood Dowel x44</p>	 <p>Spreading bolt x43</p>	 <p>Minifix cam x43</p>	 <p>Cover caps x23</p>
 <p>Sistema corredizo Door Roller x1</p>	 <p>Puntilla / nail x31</p>	 <p>Tornillo Drwyall / Drywall Screw x7</p>	 <p>Deslizador puntilla / Nail - on glide x12</p>
 <p>Grapa para fondo / Rear Panel Clamp x3</p>	 <p>Tornillo lámina / Flat head screw x10</p>		

## Cargas Máximas / Max Suggested Loads

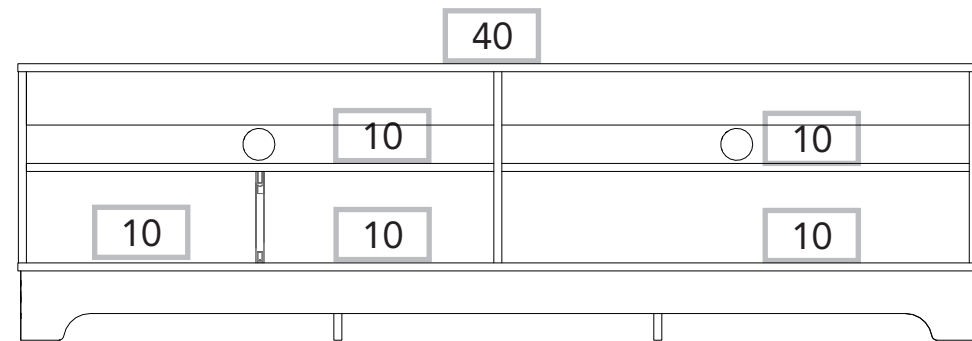

\*Peso en Kg / Weight in Kg.

# Piezas de Armado / Assembly Parts

A - x1
B - x1
C - x1
D - x1
E - x1
F - x1
G - x1
H - x1
I - x1
J - x1
K - x1
L - x1
M - x1
N - x1
O - x1
P - x1
Q - x1
R - x2
S - x2
T - x6

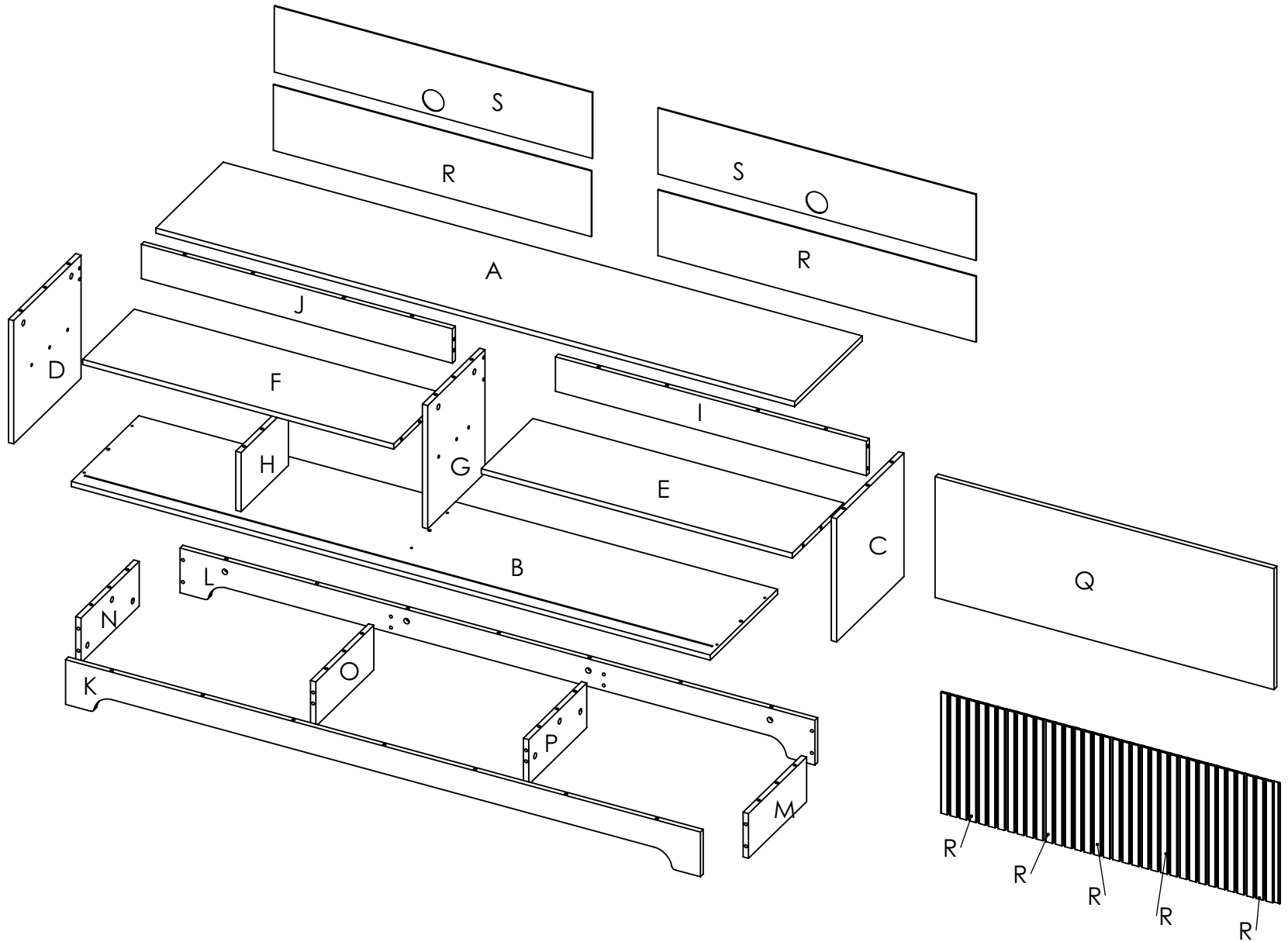

1

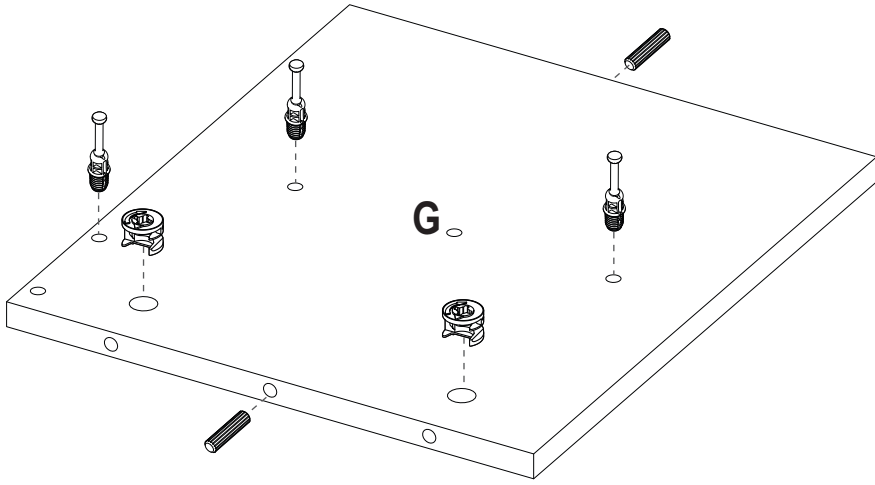

Voltear  
Rotate

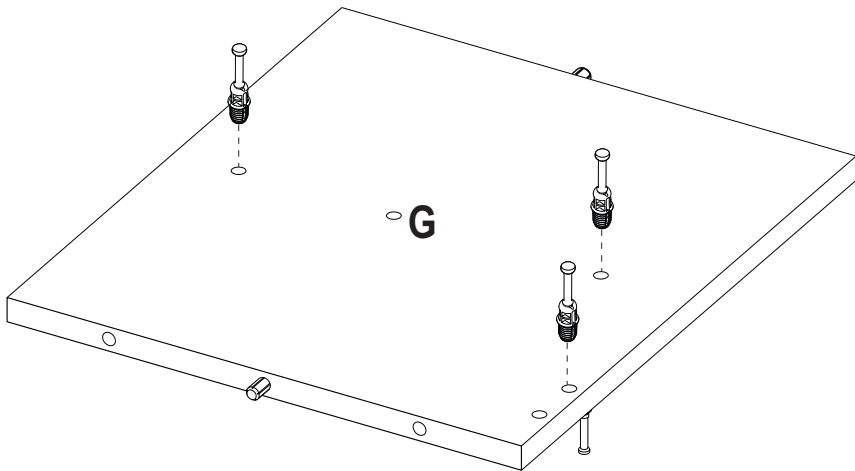

2

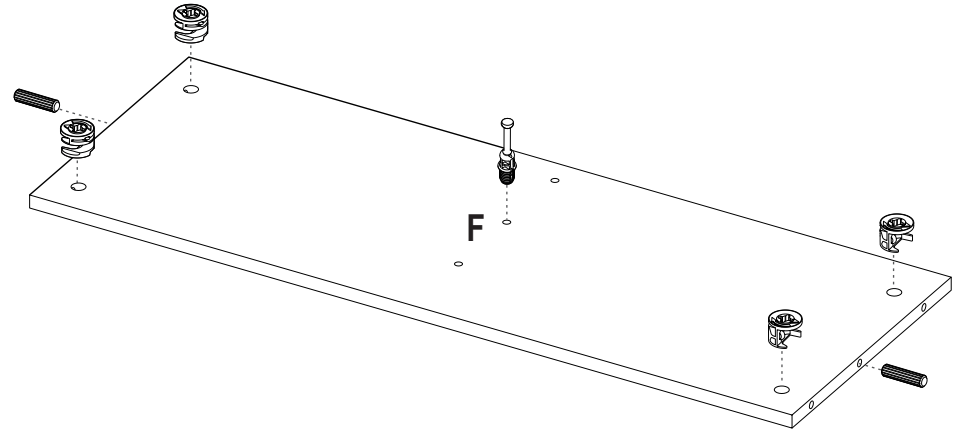

3

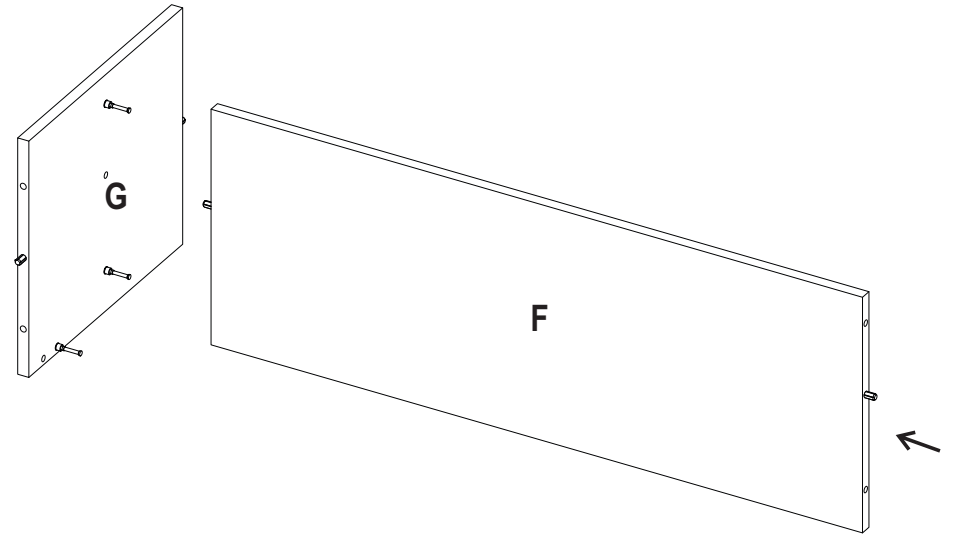

4

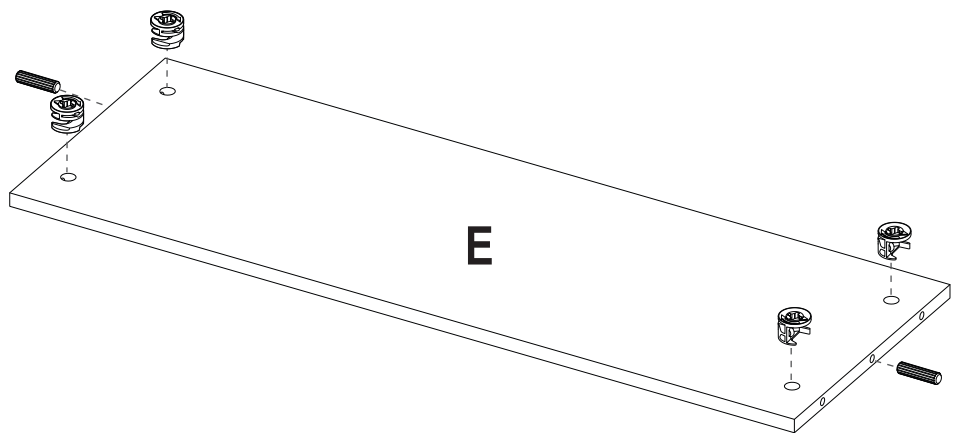

5

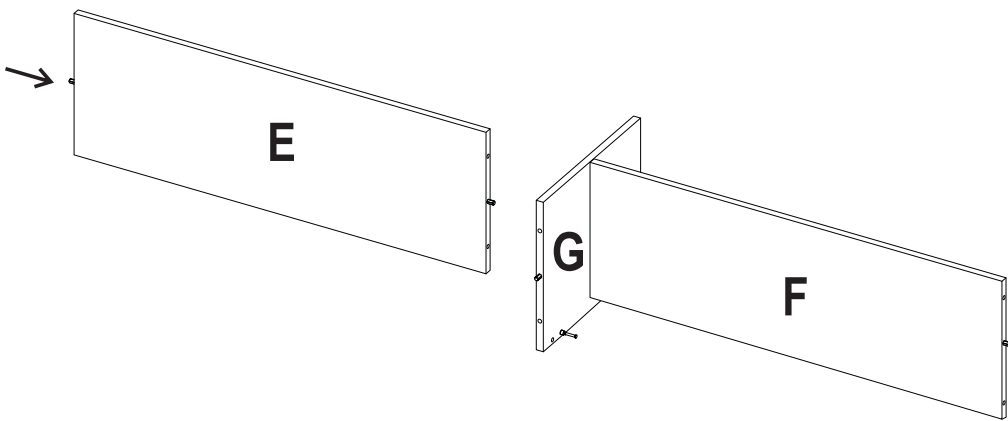

6

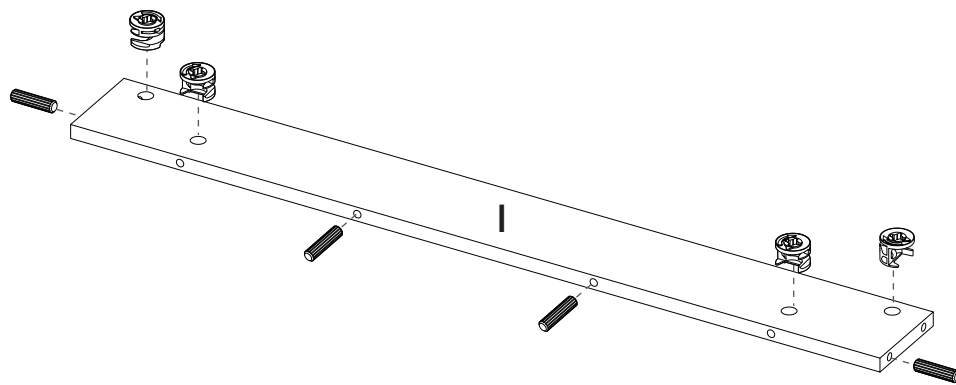

7

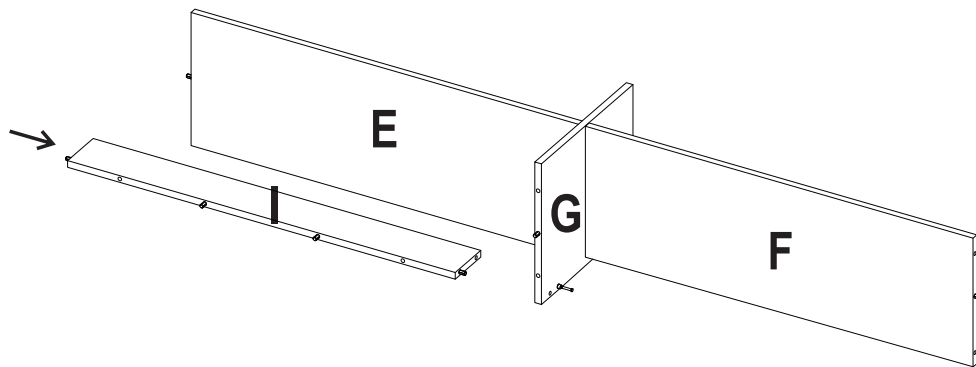

8

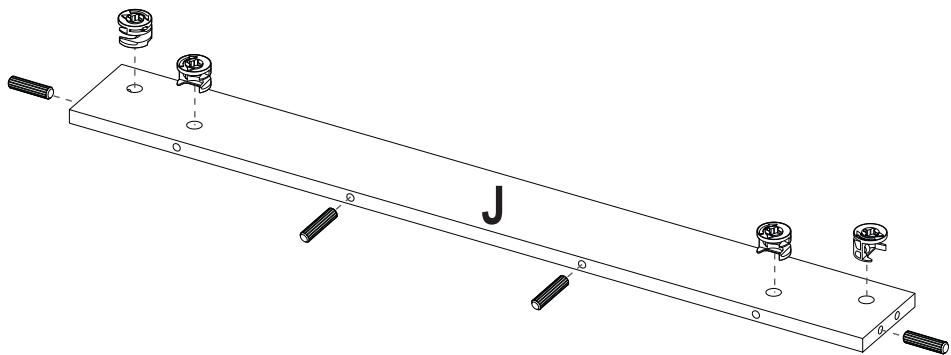

10

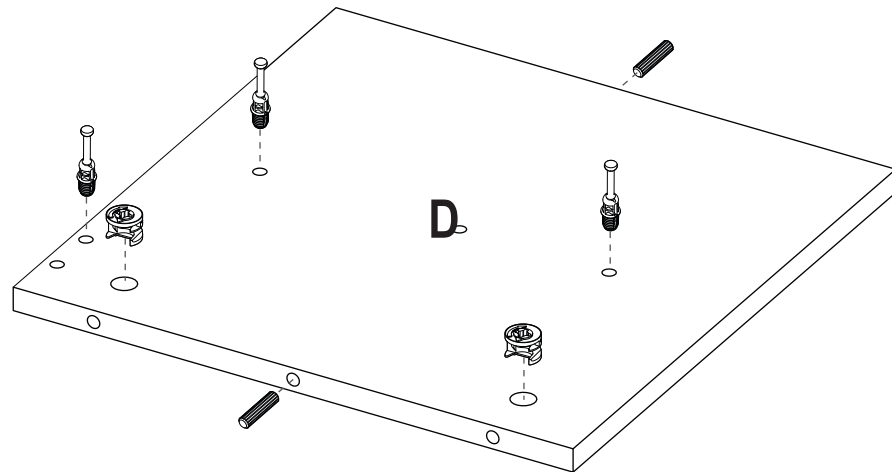

9

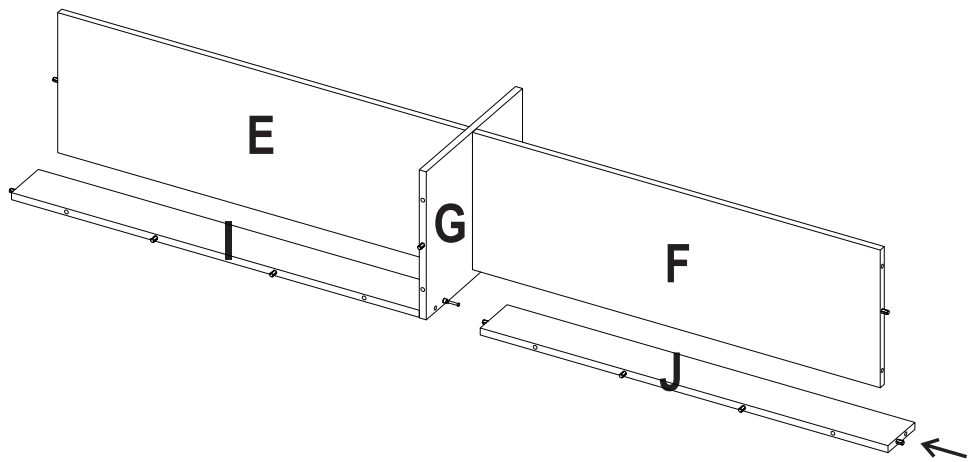

11

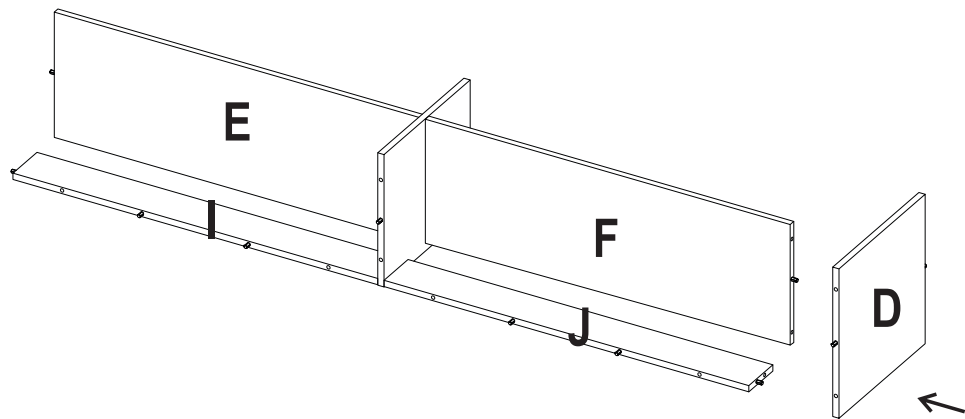

12

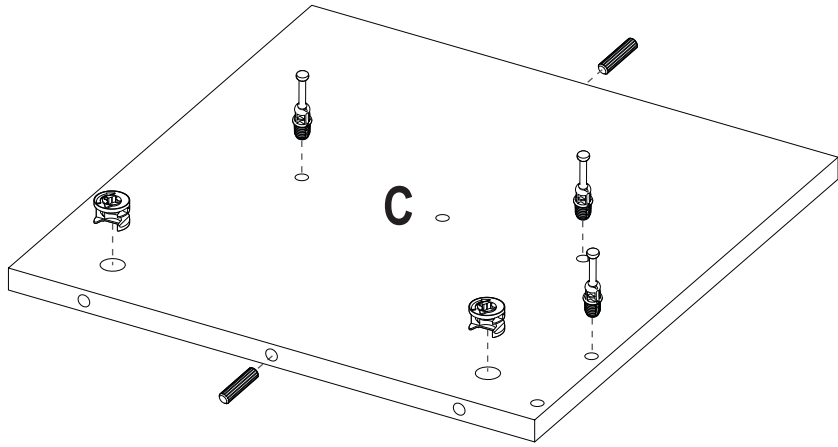

14

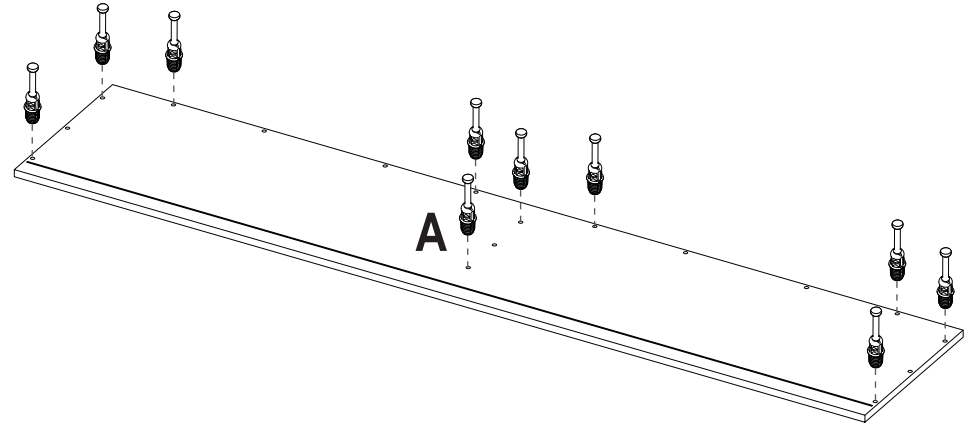

13

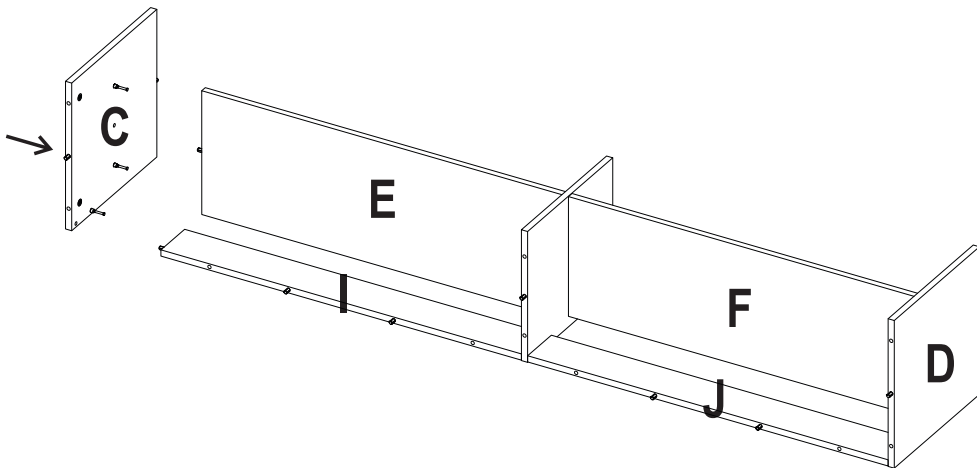

15

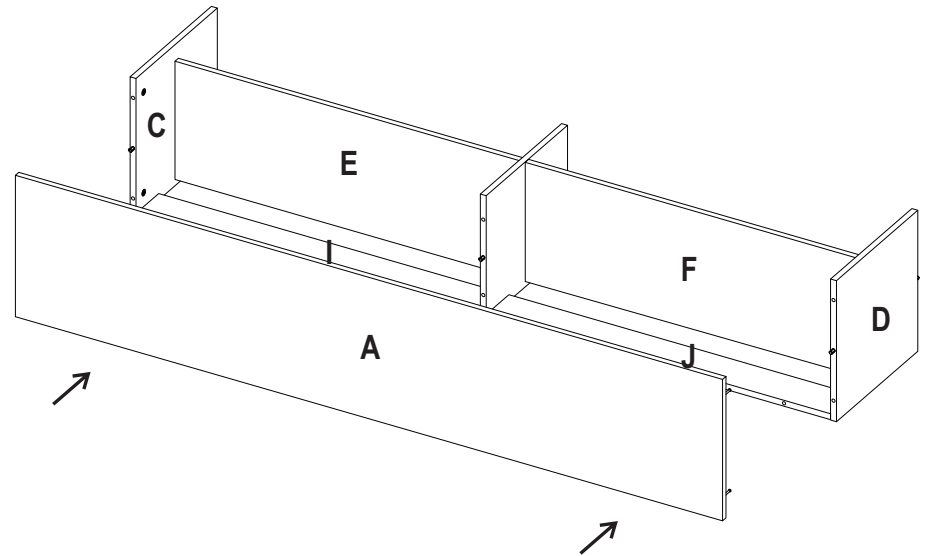

16

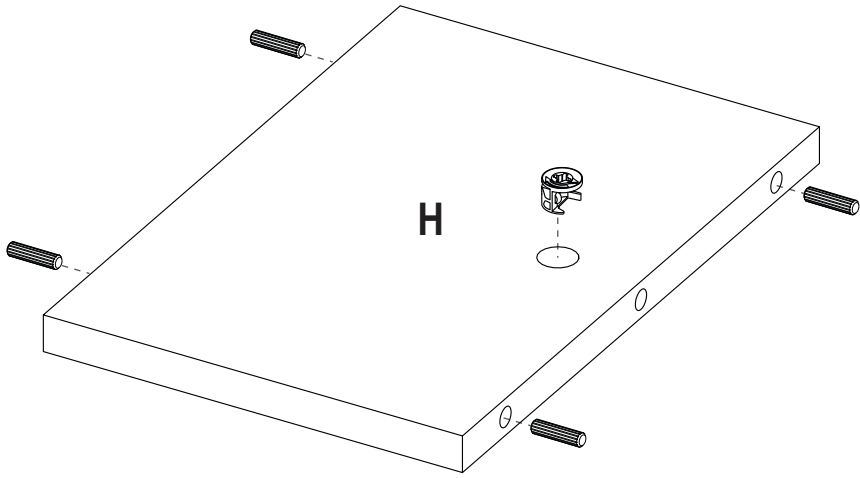

18

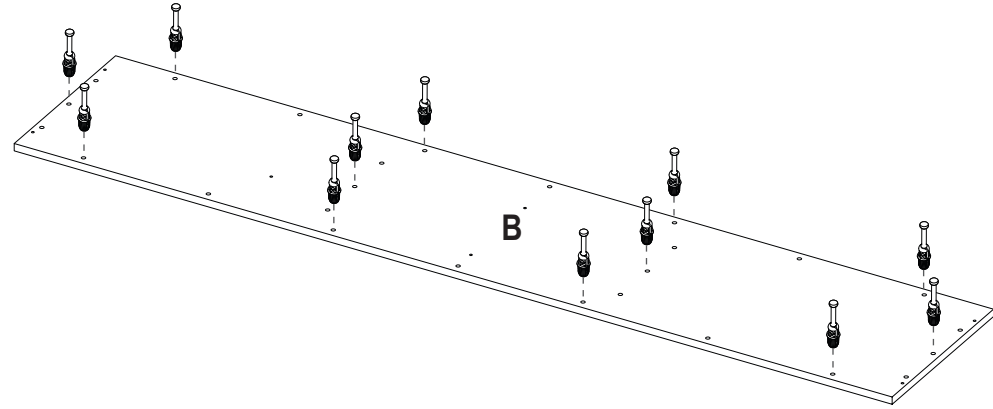

17

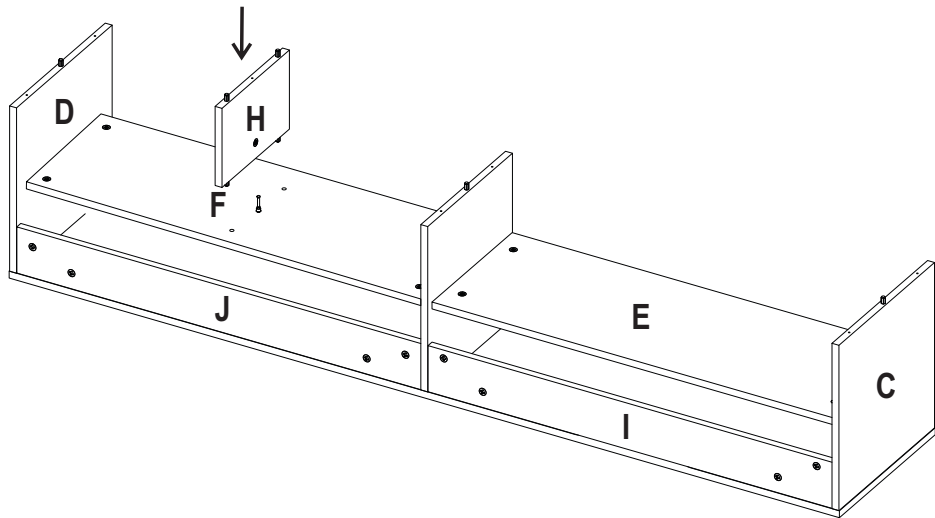

19

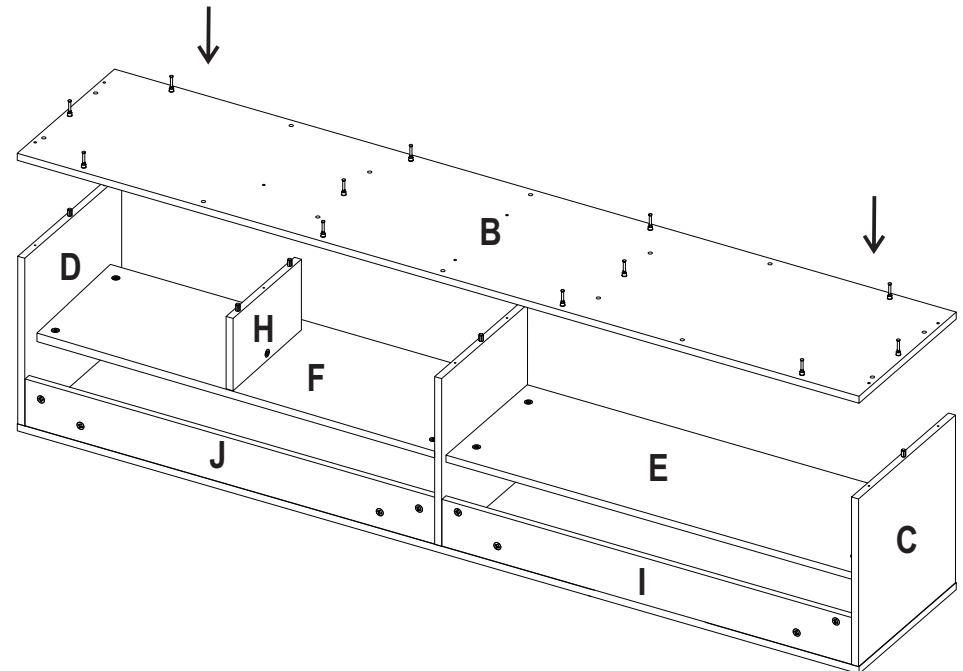

20

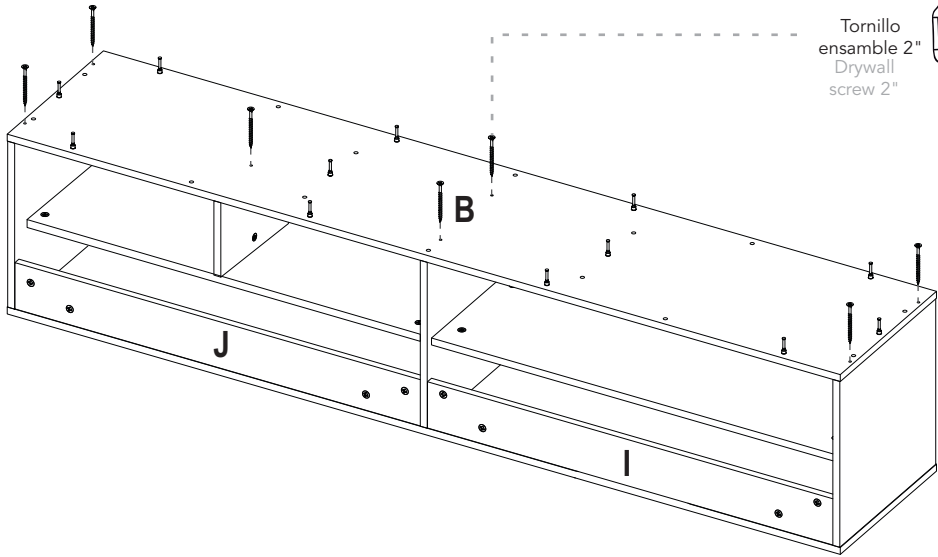

Tornillo  
ensamble 2"  
Drywall  
screw 2"



22

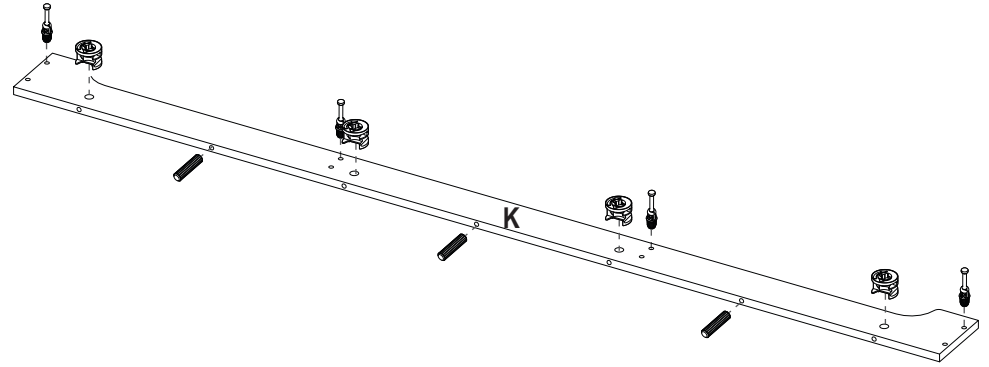

21

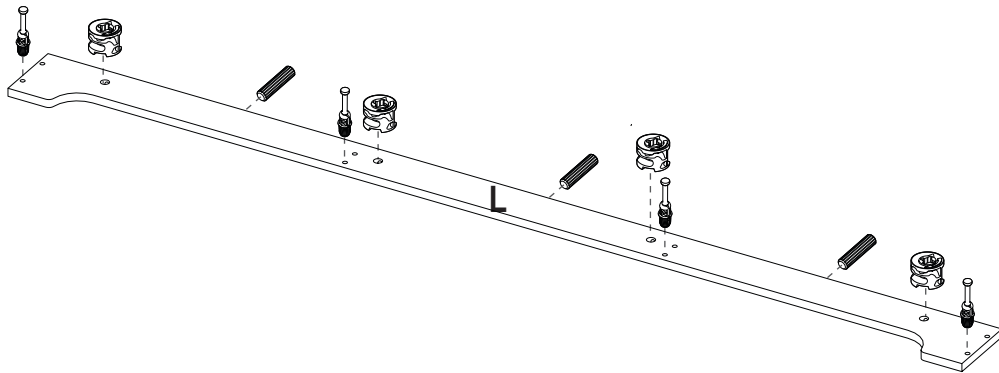

23

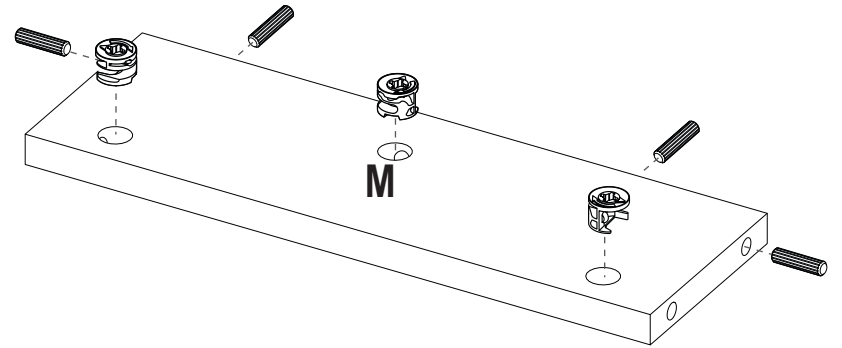

24

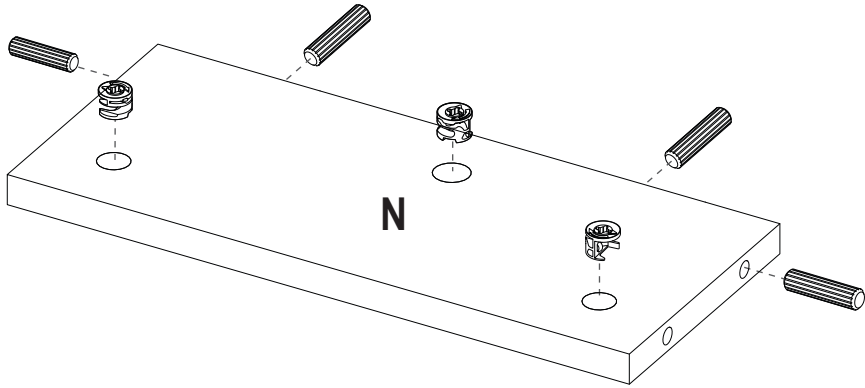

26

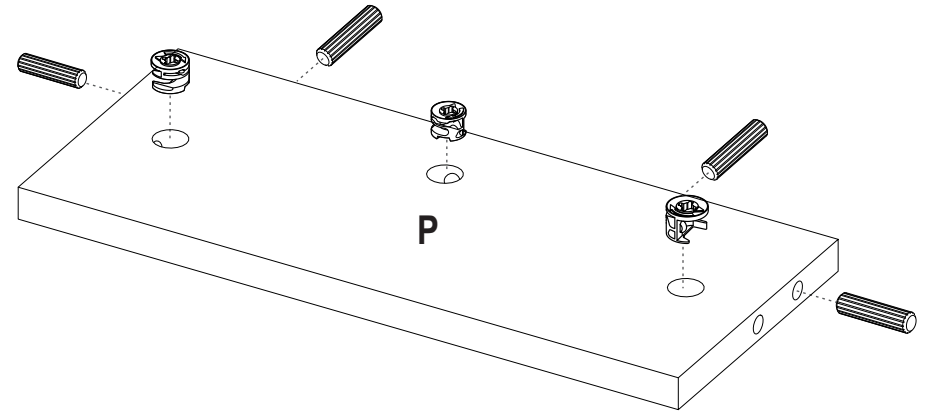

25

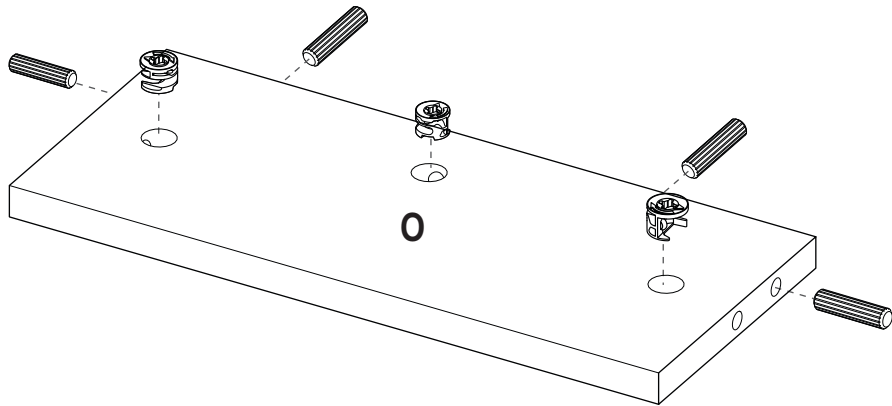

27

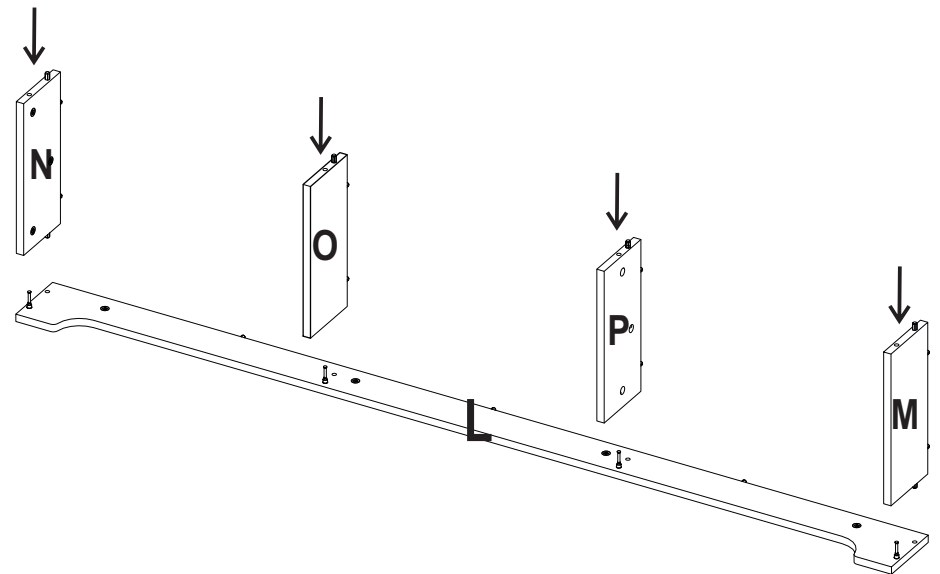

28

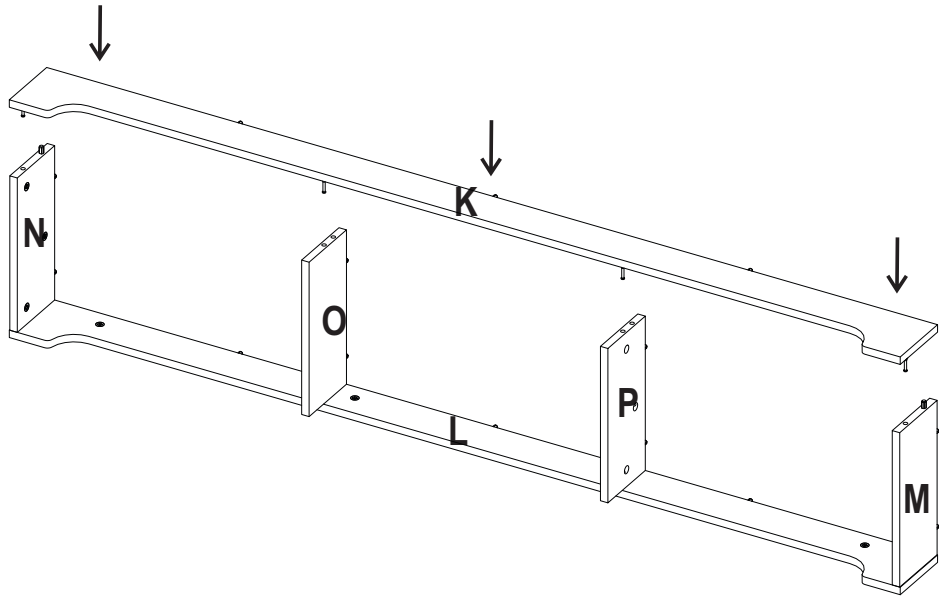

29

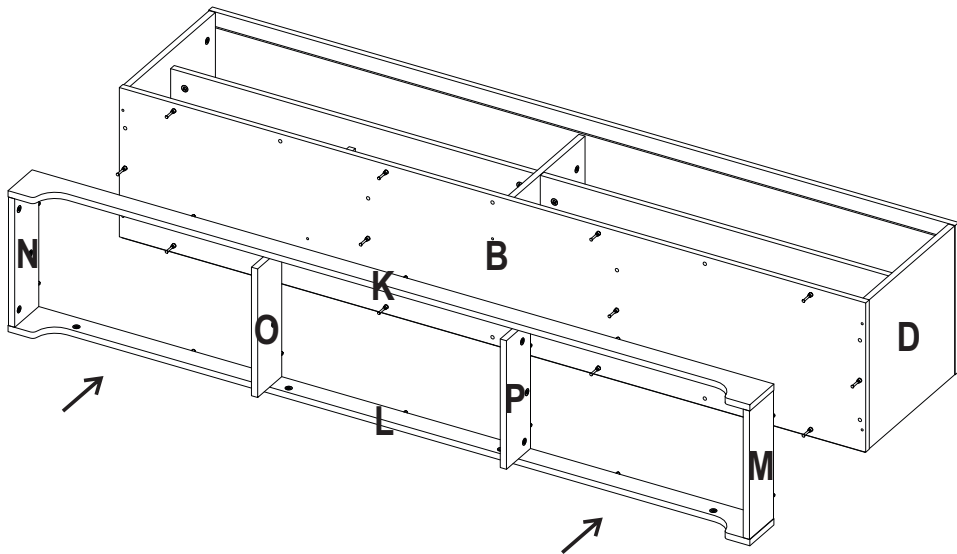

30

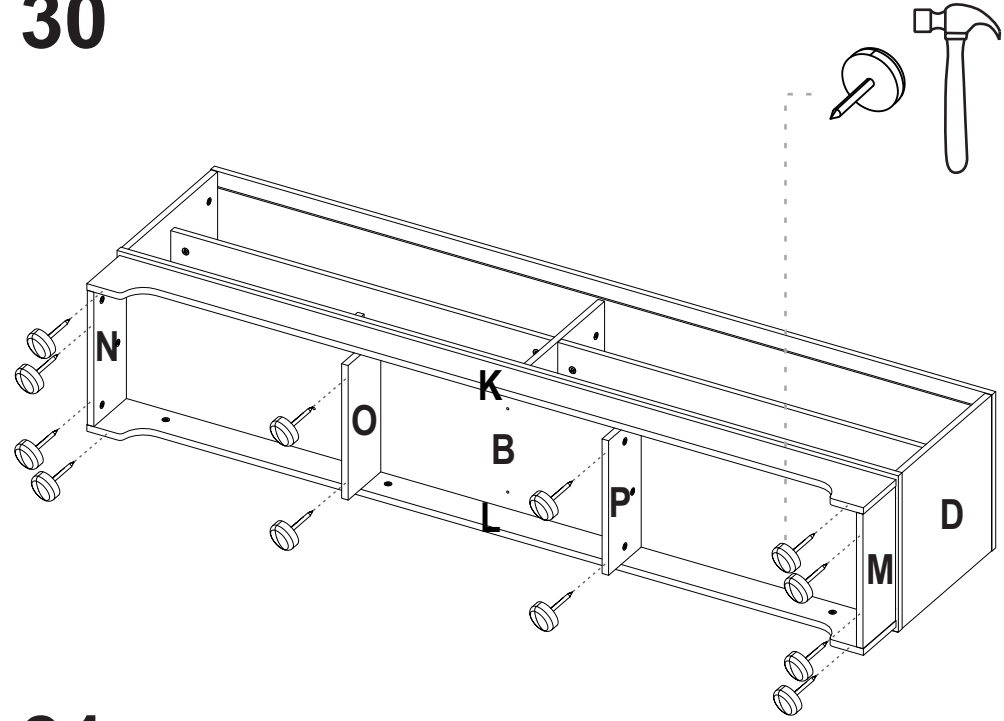

31

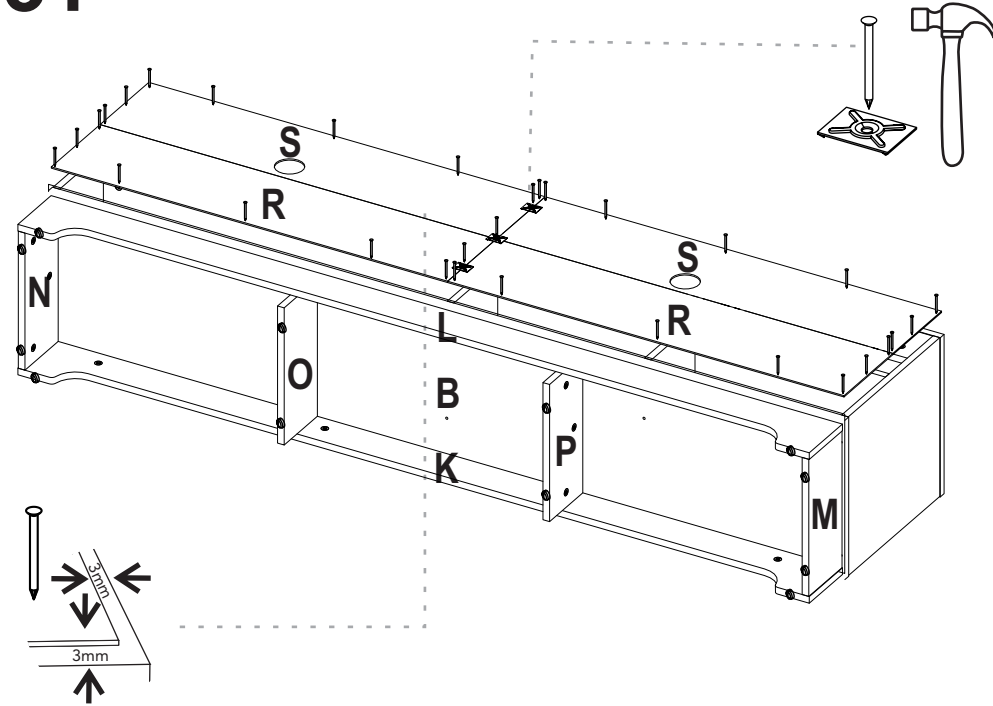

# 32

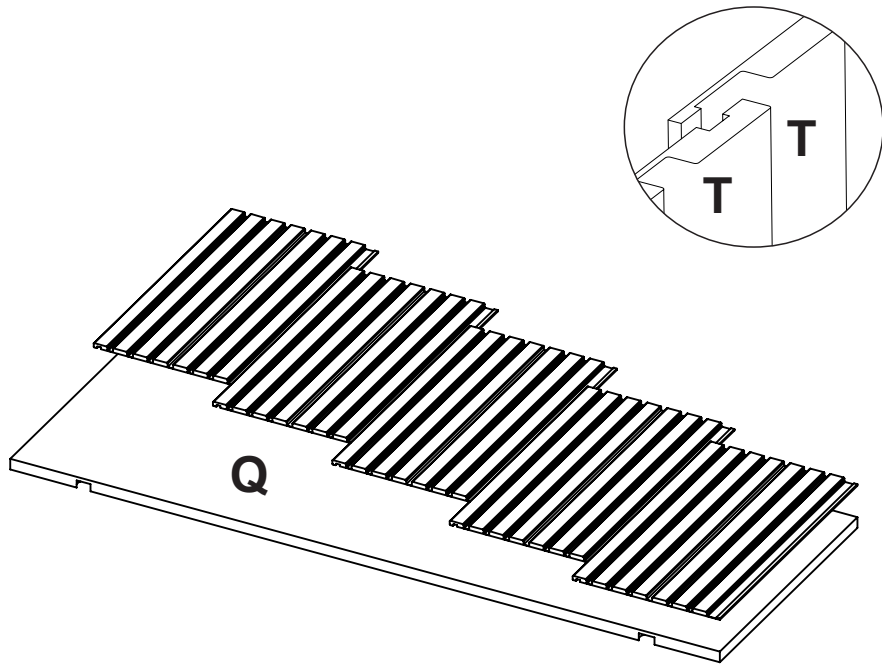

Retira el protector del adhesivo/ Remove the adhesive protector.

1

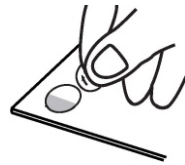

**Limpia bien las superficies y pega el panel sobre las piezas / Do a right cleaning of the surfaces, then place the panel on the pieces.**

2

Haz presión sobre el Panel  
Press on the panel

# 33

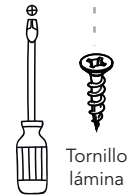
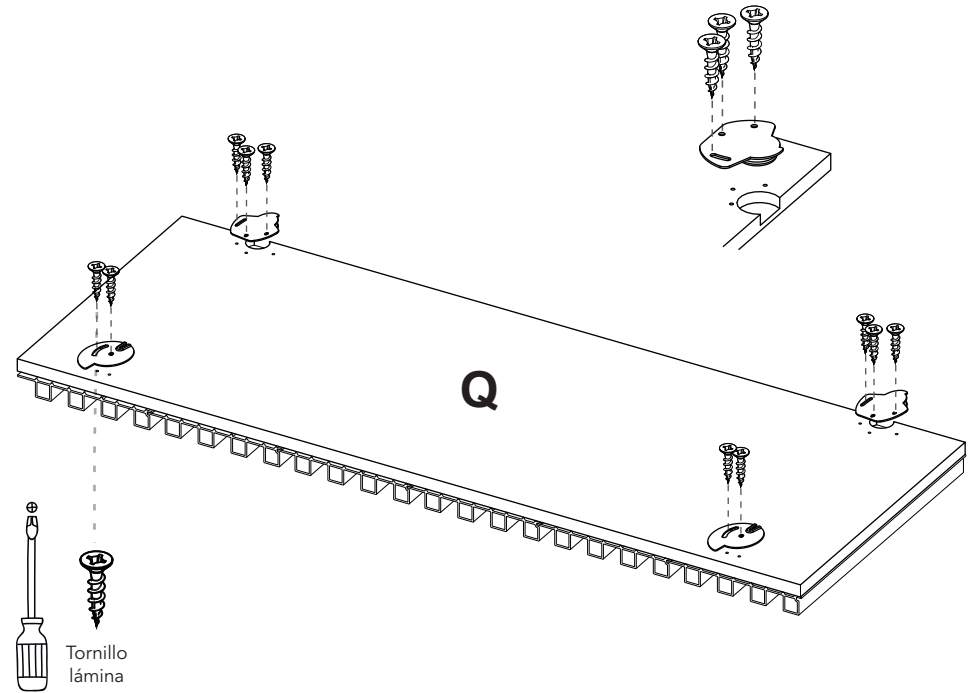

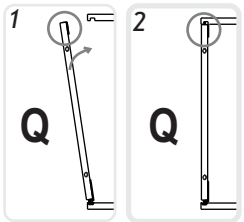
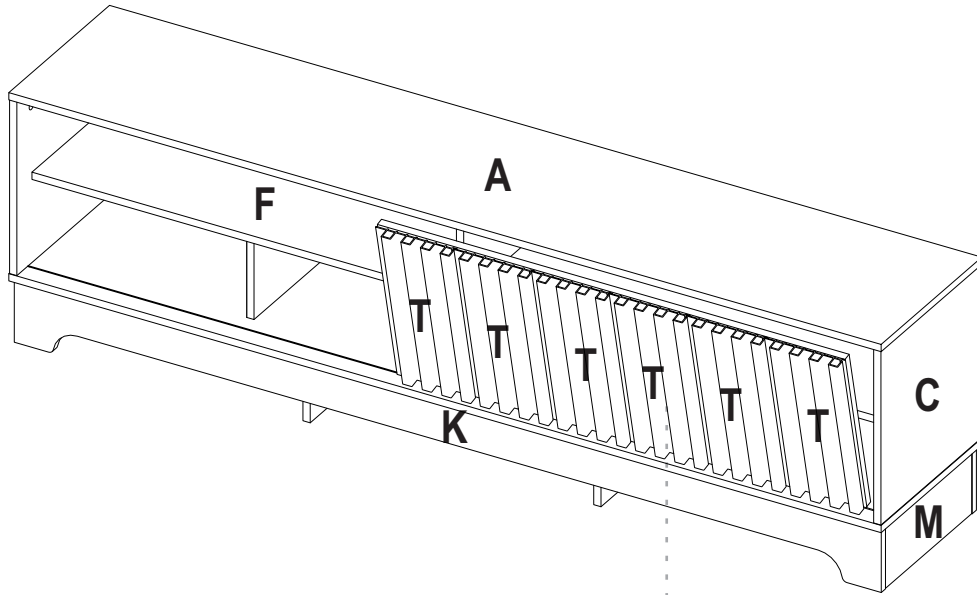

Instalación  
puertas corredizas / Sliding  
door installation

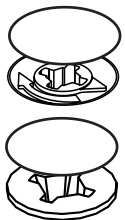

Después de ajustar todas las  
cajas minifix y los tornillos,  
cúbralas con las tapas adhesivas.  
After you finish the adjustment  
of the cams and screws,  
cover them with the  
cover caps.



Al terminar de armar,  
desprenda las letras  
adhesivas.  
After you finish  
assembling the cabinet,  
take off the adhesive  
letters.