

14 Passo Step Paso

2x

Regulagem correção  
Sliding adjustment  
Regalje corredera

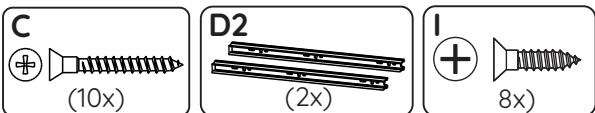
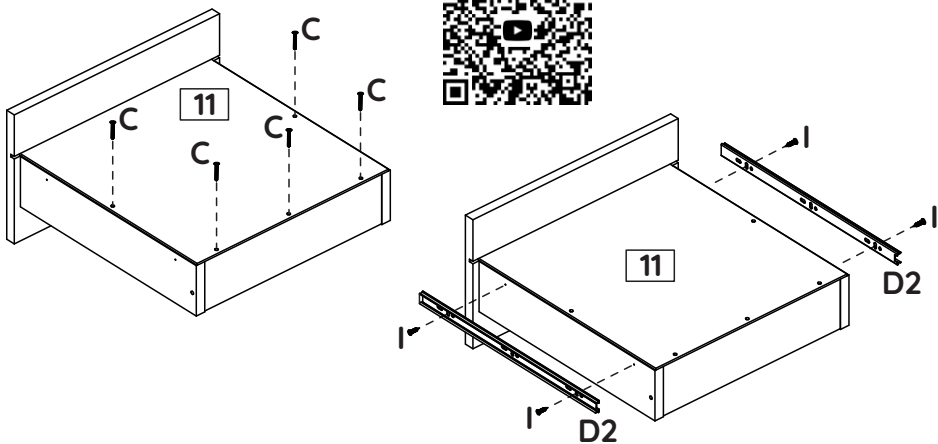

15 Passo Step Paso

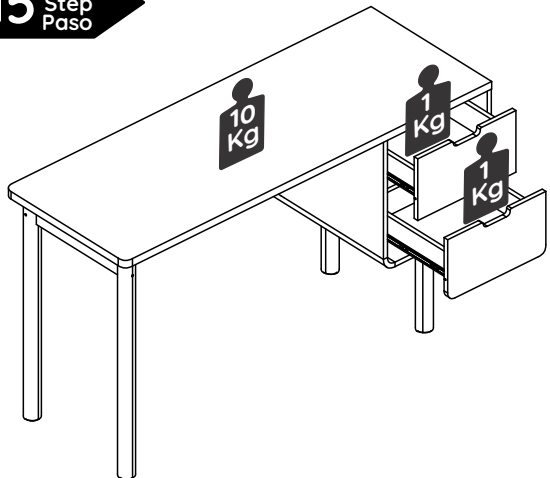

Dicas de Conservação / Maintenance Tips / Consejos de Mantenimiento

\*Para limpar ou tirar manchas, utilize uma flanela umedecida em solução de água e álcool, na mesma proporção. Evite exposição ao sol.

\*To clean or remove stains, use a piece of flannel dampened with a water and alcohol solution, in the same proportion. Avoid direct sunlight.

\*Para limpiar o sacar manchas, utilice una flanela humedecida en solución de agua y alcohol, en la misma proporción. Evite la exposición directa al sol.



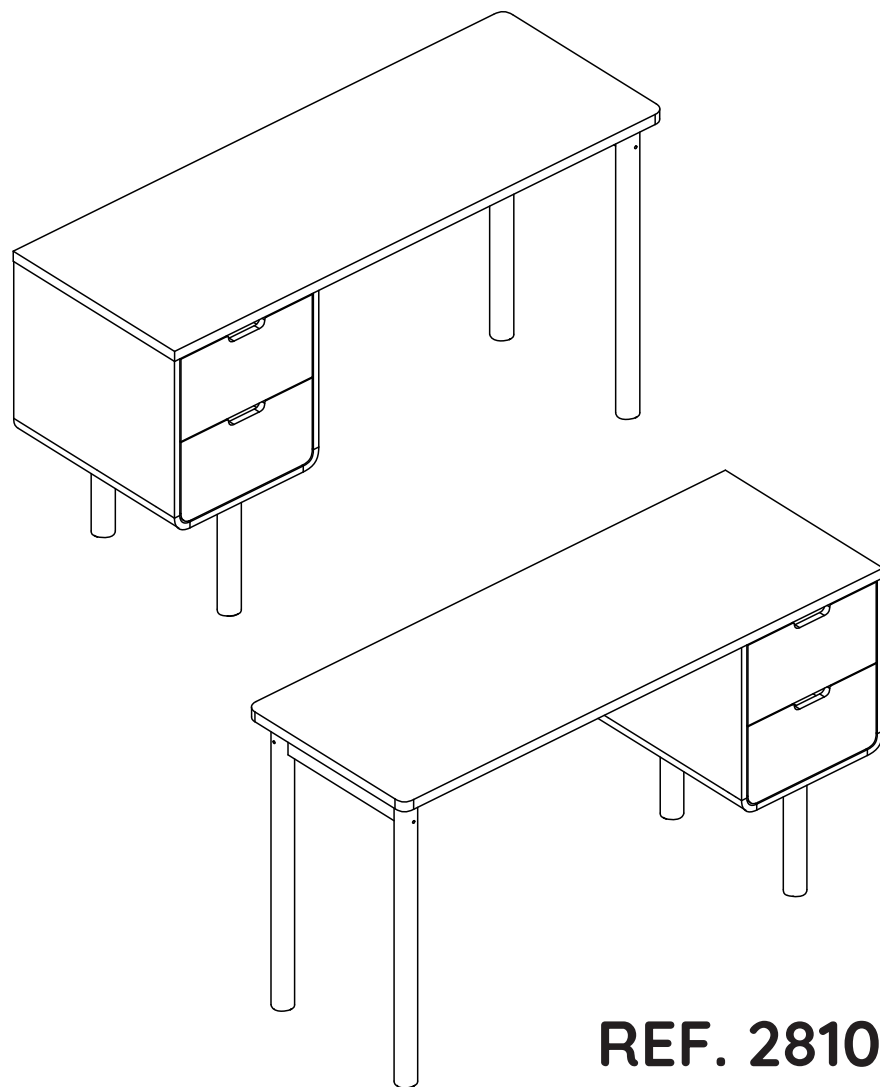







INSTRUÇÕES DE MONTAGEM  
ASSEMBLY INSTRUCTIONS  
INSTRUCCIONES DE MONTAJE

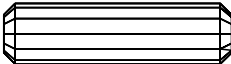
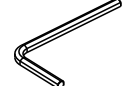

REF. 28106

# FERRAGENS / HARDWARE LIST / LISTA DE HERRAJES

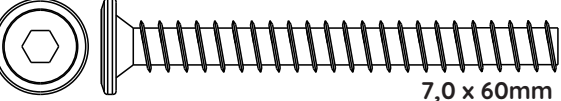
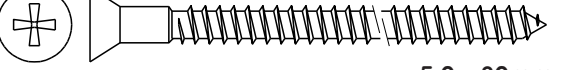
Os desenhos das ferragens são em escala real, então suas dimensões são iguais as das ferragens reais.  
 The hardware drawings are full-scale, so their dimensions are the same as the actual hardware.  
 Los dibujos de los herrajes son la escala real, por lo que sus dimensiones son las mismas que las del herraje real.

ID	IMAGEM DE REFERÊNCIA / IMAGE REFERENCE IMAGEN REFERENCIA	QUANTIDADE # OF PIECES CANTIDAD
A	 4,5 x 45mm	04
B		20
C	 3,5 x 30mm	10
D	 350mm	02
E		20
F	 3mm	06
G	 8x30mm	28
H		01
I	 3,5 x 14mm	16
J	 7,0 x 60mm	02
K	 5,0 x 80mm	03
L		04

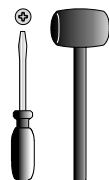

## 12 Passo Step Paso

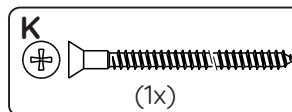
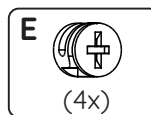
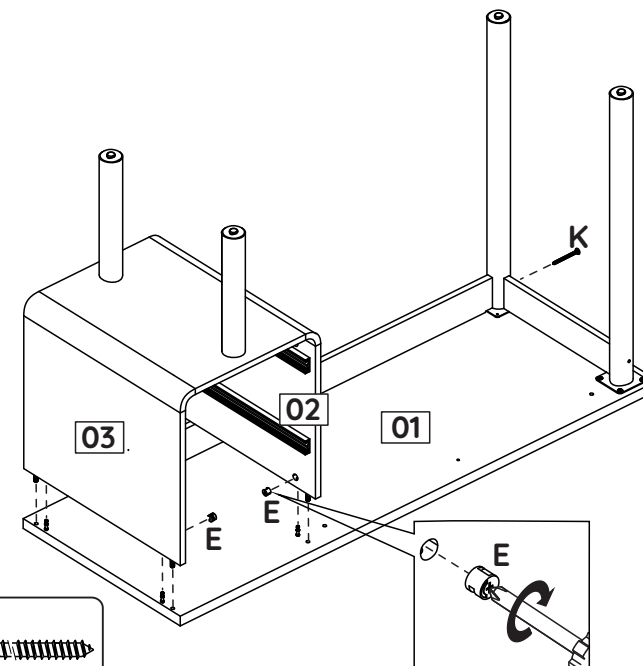

## 13 Passo Step Paso

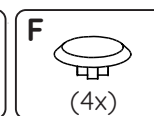
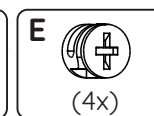
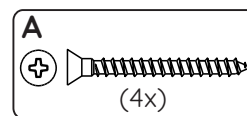
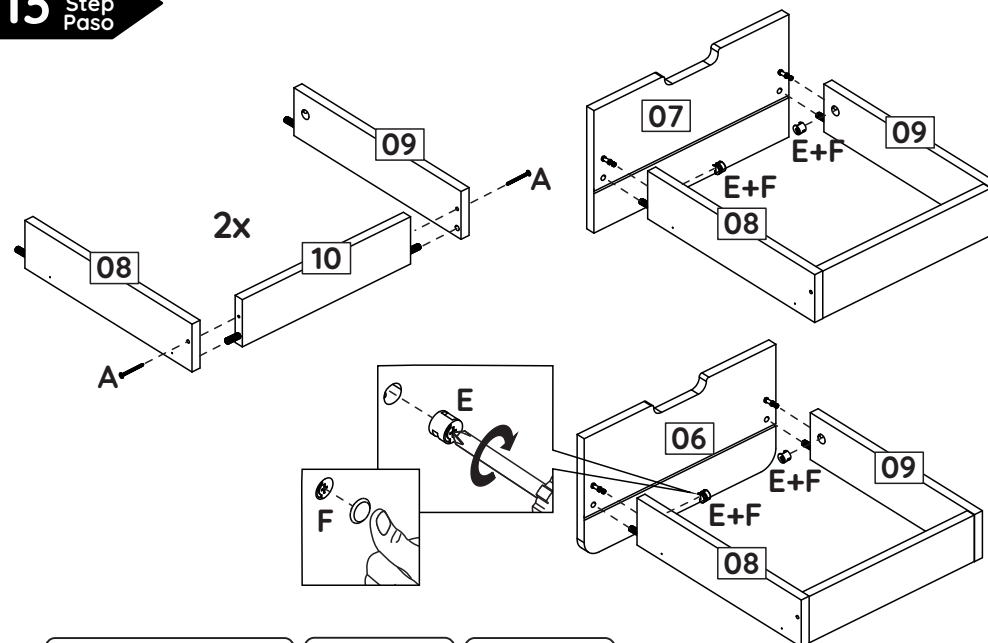

**10** Passo  
Step  
Paso

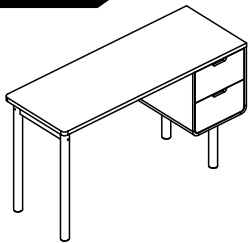

**Montagem gaveta lado direito**  
Drawer assembly right side  
Armado cajón en el lado derecho

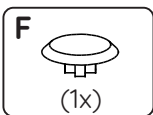
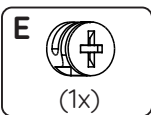
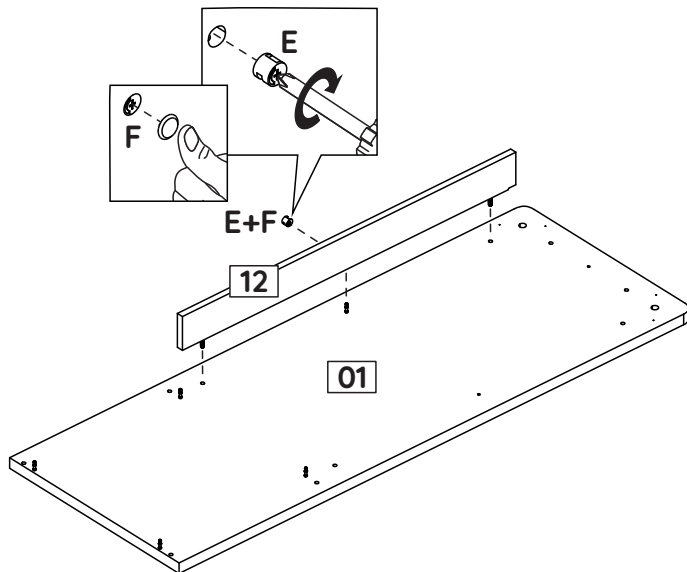

**11** Passo  
Step  
Paso

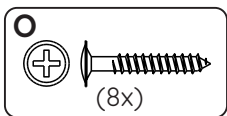
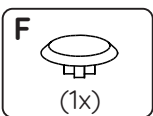
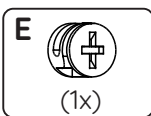
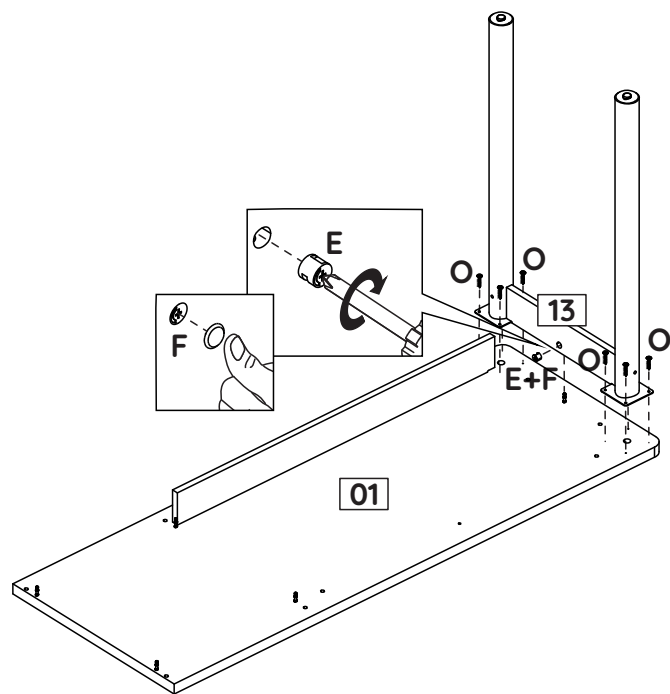

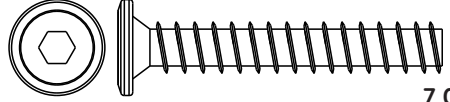
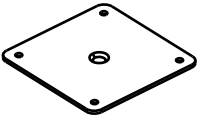
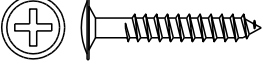
ID	IMAGEM DE REFERÊNCIA / IMAGE REFERENCE IMAGEN REFERENCIA	QUANTIDADE # OF PIECES CANTIDAD
M	 7,0 x 40mm	02
N	 80 x 80mm	02
O	 4,5 x 25mm	08

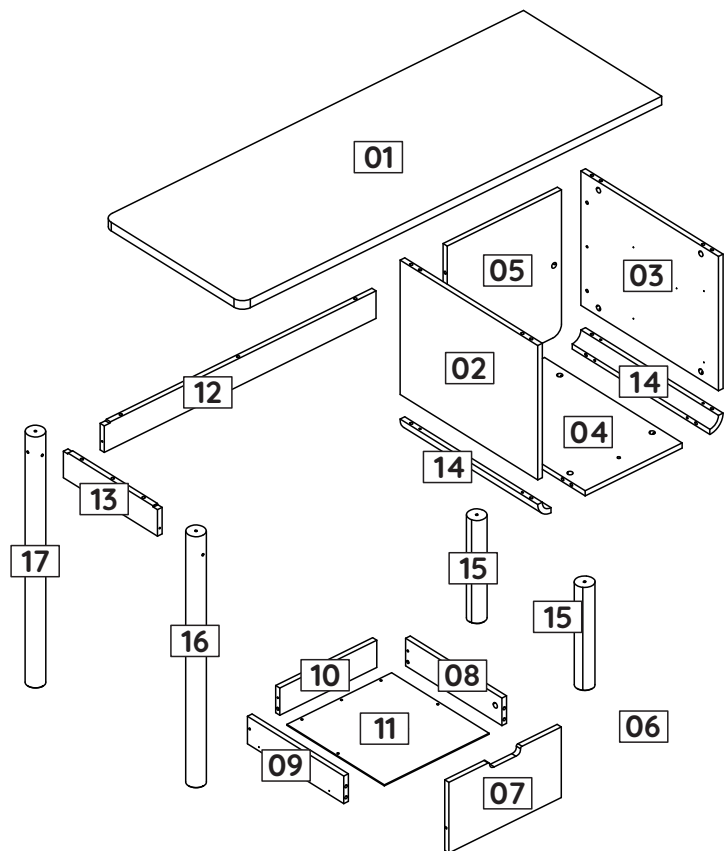

ID	Descrição / Description / Denominación	Quantidade # Of Pieces Cantidad	Dimensão (mm) Dimension (mm) Dimensión (mm)
01	Tampo/Top/Tapa	01	1360x502x25
02	Lateral esquerda/Left side/Lateral izquierda	01	390x500x15
03	Lateral direita/Right side/Lateral derecha	01	390x500x15
04	Base/Base/Base	01	314x500x15
05	Costa/Back/Revés	01	418x370x15
06	Frente gav. inferior/Lower drawer front/Frente cajón inferior	01	205x364x15
07	Frente gav. superior/Upper drawer front/Frente cajón superior	01	205x364x15
08	Lateral direita gaveta/Right drawer side/Lateral derecha cajón	02	350x80x15
09	Lateral esq gaveta/Left drawer side/Lateral izquierda cajón	02	350x80x15
10	Costa gaveta/Drawer back/Revés cajón	02	314x79x15
11	Fundo gaveta/Drawer bottom/Fondo cajón	02	339x354x3
12	Travessa/Crossbar/Travessaño	01	880x80x15
13	Travessa lateral/Side crossbar/Travessaño lateral	01	342x80x15
14	Moldura/Detail/Detalle	02	500x43x43
15	Pé de madeira menor/Small wood foot/Pata de madeira menor	02	300x50x50
16	Pé de madeira frontal/Front wood foot/Pata de madeira delantera	01	730x50x50
17	Pé de madeira tras/Back wood foot/Pata de madeira trasera	01	730x50x50

**8** Passo  
Step  
Paso

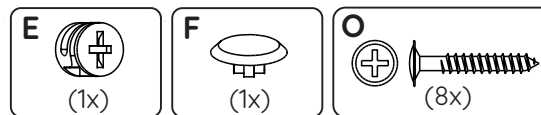
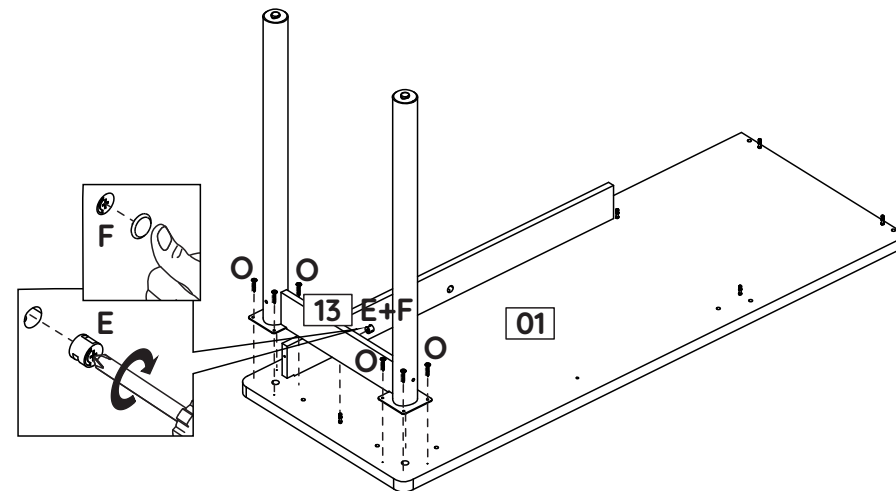

**9** Passo  
Step  
Paso

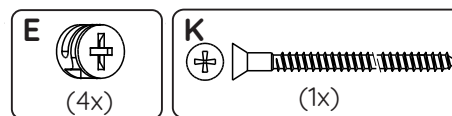
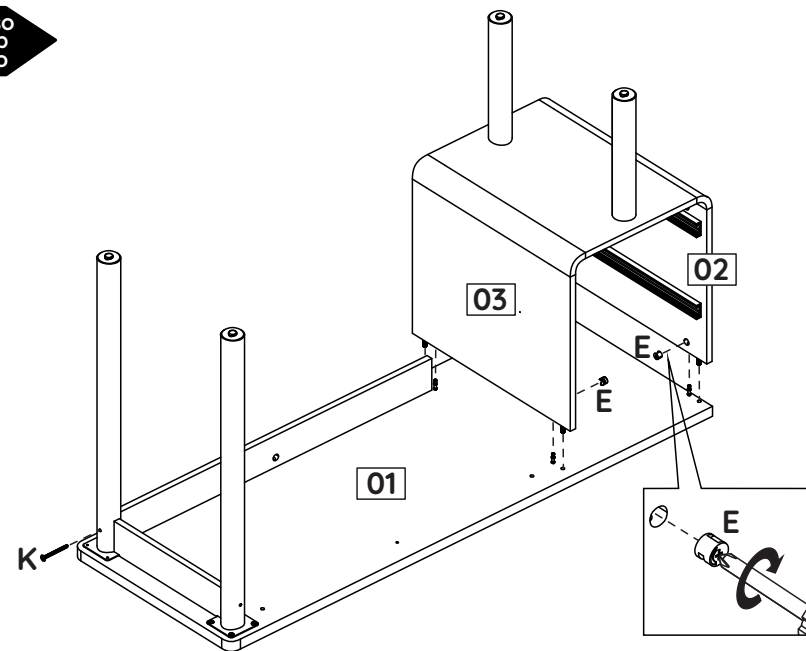

**6** Passo  
Step  
Paso

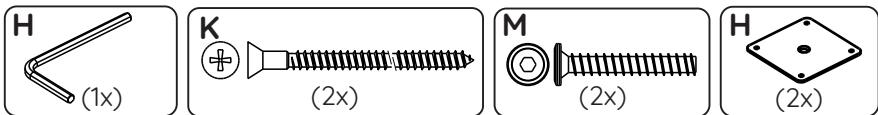
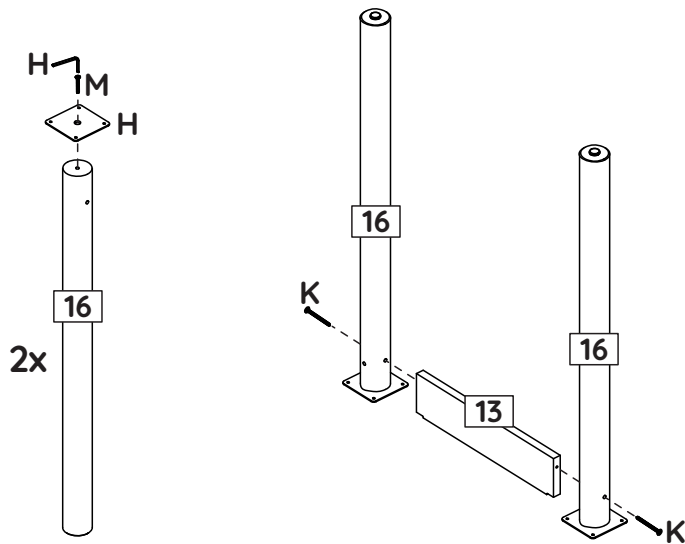

**7** Passo  
Step  
Paso

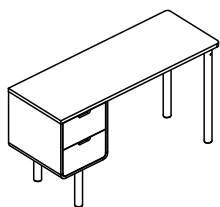

Montagem gaveta  
lado esquerdo  
Drawer assembly  
left side  
Armado cajón en  
el lado izquierdo

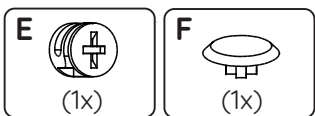
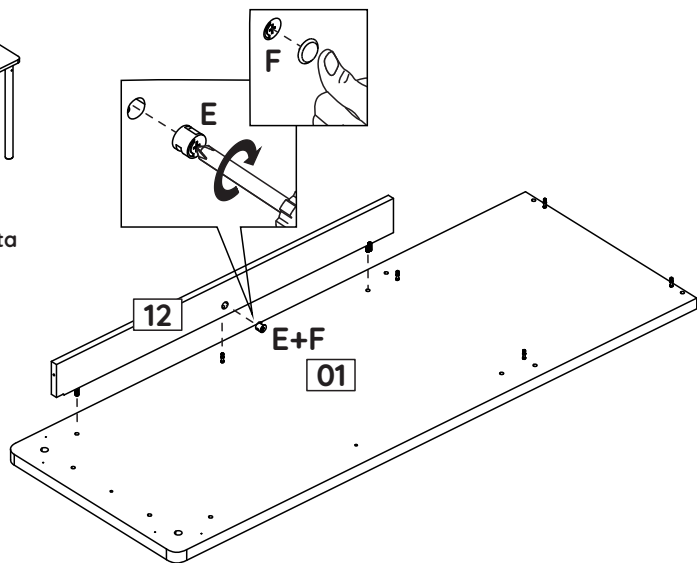

**1** Passo  
Step  
Paso

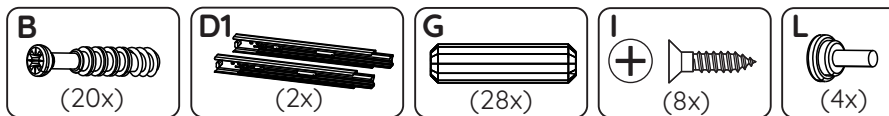
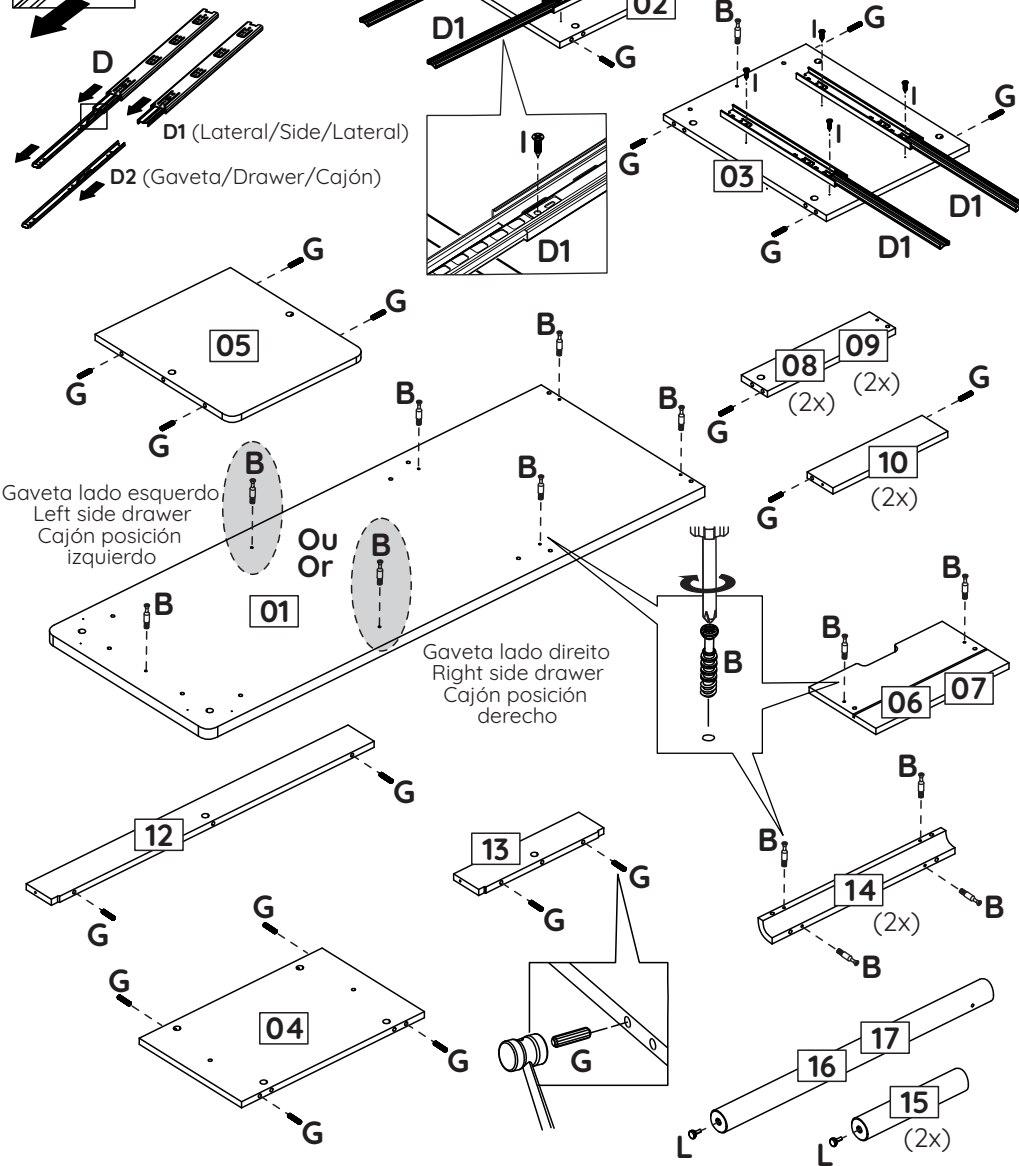
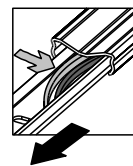

**2** Passo  
Step  
Paso

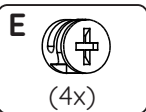
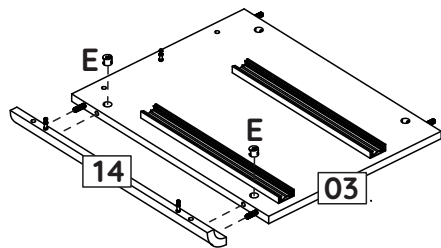
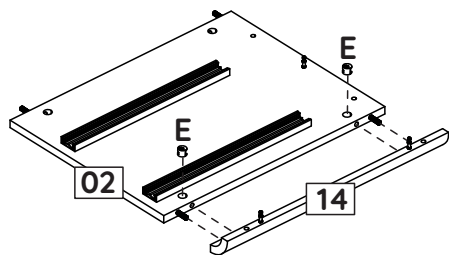

**3** Passo  
Step  
Paso

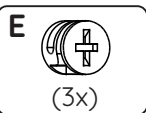
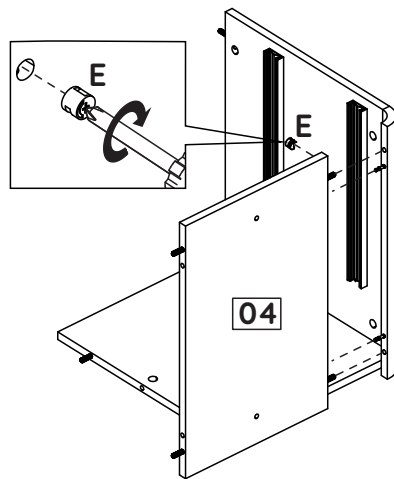
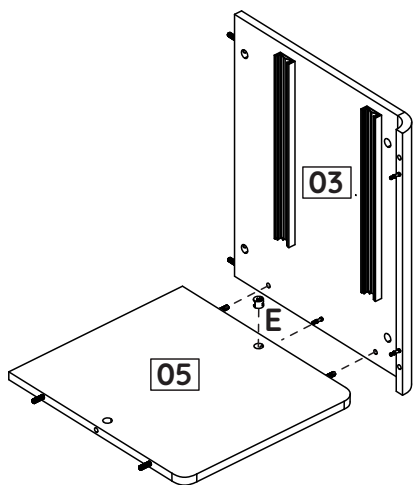

**4** Passo  
Step  
Paso

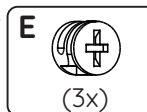
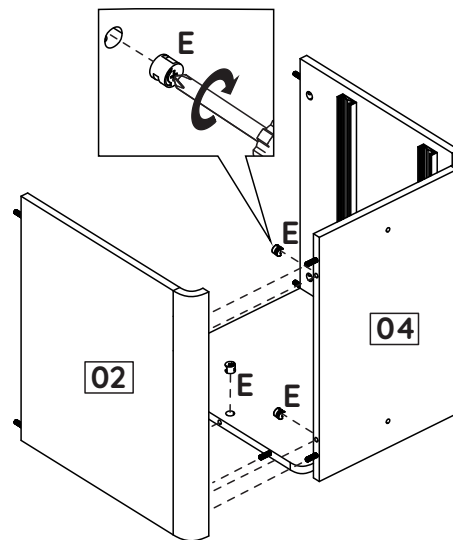

**5** Passo  
Step  
Paso

