

INSTRUCCIONES DE ARMADO / ASSEMBLY INSTRUCTIONS
MUEBLE MICROONDAS SEDONA / SEDONA MICROWAVE KITCHEN CABINET

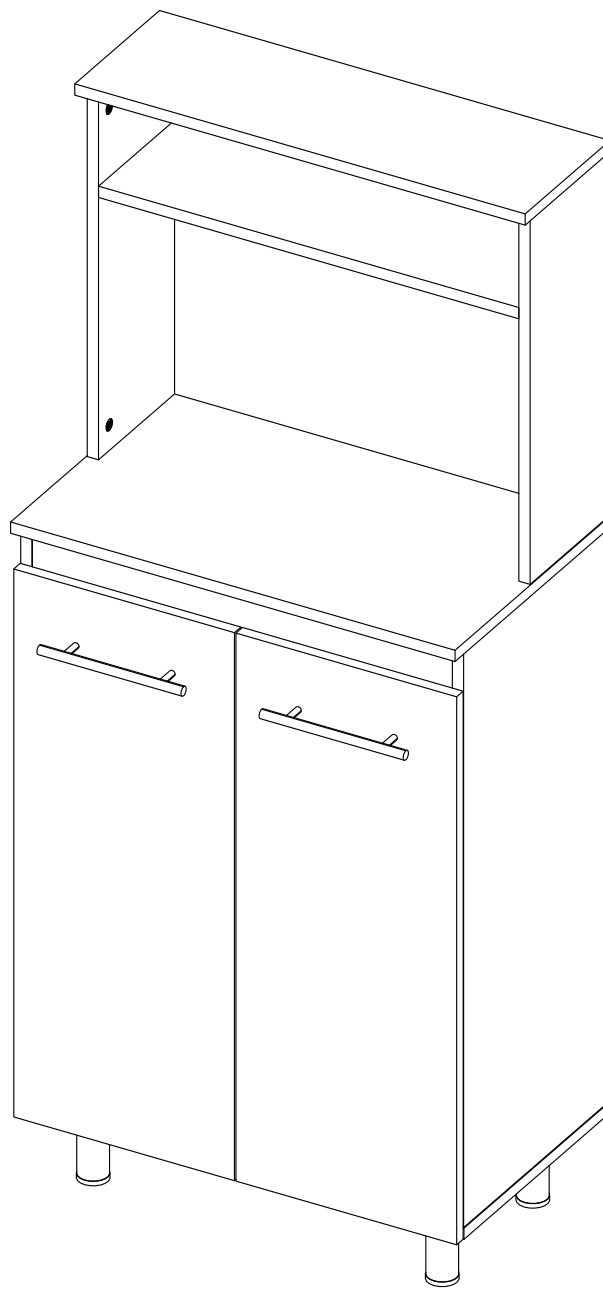

LOT N°



¡ATENCIÓN! / ATTENTION!

En las próximas páginas está el contenido de las piezas y herrajes del mueble. Asegúrate de que la cantidad de herrajes y piezas que hay en la caja sea la correcta y todo esté en buen estado. Ya que cuando el mueble esté armado no podrás realizar ninguna reposición.

On the next pages is the content of the pieces and hardware of the furniture.

Make sure the number of hardware and parts in the box is correct and everything is in good condition. When the furniture is assembled you will not be able to make any replacement

Recomendaciones Importantes / Key Recommendations

- Ensamble el mueble entre dos personas. / Assemble the cabinet between two people.
- Ensamble el mueble sobre una superficie plana y lisa, preferiblemente sobre un tapete o el cartón de la caja. / Assemble the cabinet on a flat smooth surface, preferably on a carpeted floor or the box carton.
- Se recomienda utilizar un destornillador eléctrico para facilitar el ensamble / It is recommended to use an electric screwdriver to facilitate assembly.

Herramientas Necesarias / Required Tools

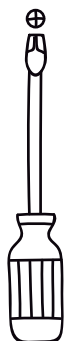

Destornillador de estrella
Phillips Head
Screwdriver



Destornillador de pala
Flat Head
Screwdriver

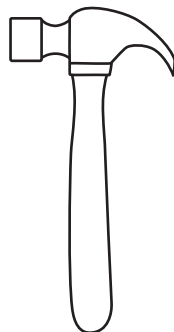

Martillo
Hammer

Herrajes Básicos / Basic Hardware

Aplica estas instrucciones cada vez que vayas a utilizar uno de estos herrajes durante el armado. / Apply these instructions everytime you're using one of these connectors during the assembly.

Tarugos / Wood Dowels

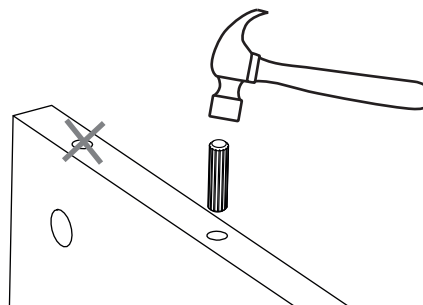

1. Inserta el tarugo en la perforación indicada y golpéalo suavemente hasta que llegue hasta el final de la perforación. / Put in the dowel inside the indicated hole and softly hit it until it's fully inside.

2. Verifica que NO se inserte el tarugo en la perforación de la caja minifix. / Verify that the dowel is NOT inserted into the perforation of the minifix cam.



Para más información
escanea AQUÍ
Scan for more info

Minifix y Pernos / Minifix Cam & Spreading Bolt

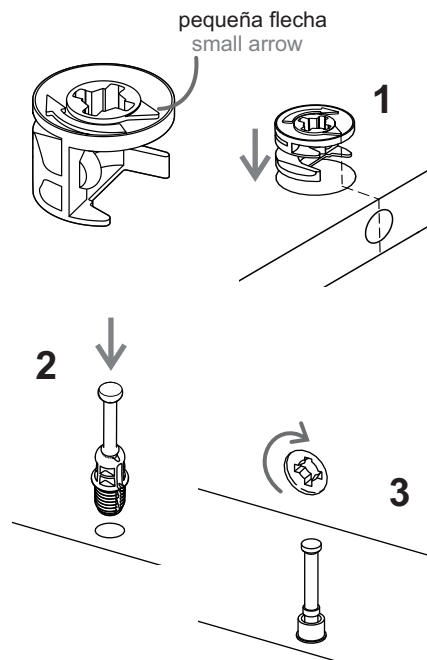





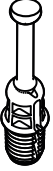

1. La caja minifix tiene una pequeña flecha en su parte superior, se debe insertar las cajas minifix con la flecha apuntando hacia la perforación que hay en el borde de la pieza. / The Minifix cam has a little arrow on its upper surface you should insert these cams with the little arrow pointing towards the drilling on the panel's edge.

2. Se debe insertar el perno con la parte plástica hacia abajo. / The spreading bolt should be put with the black plastic part facing down edge.

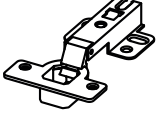
3. Luego de unir las piezas, se deben girar 180° las cajas minifix con un destornillador de estrella para ajustar y asegurar el ensamble. / After joining two panels together you should turn the cams 180° with a phillips head screwdriver to adjust and secure the joint.

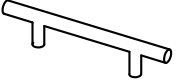
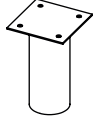
Herrajes / Hardware

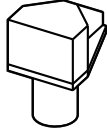
			
Tarugo / Wood dowel	Perno Minifix / Spreading Bolt	Caja Minifix / Minifix Cam	Bisagra parche + tornillos / Full overlay hinge + screws
x27	x18	x18	x4
			
Tapa Minifix / Cover Caps	Manija Negra + tornillos / Handle + screws	Pata Negra de Acero/ Steel Leg	Tornillo Lámina / Flat Head Screw
x20	x2	x4	x16
			
Puntilla / Nail	Soporte entrepaña / Shelf support		
x24	x4		

Cargas Máximas / Max Suggested Loads

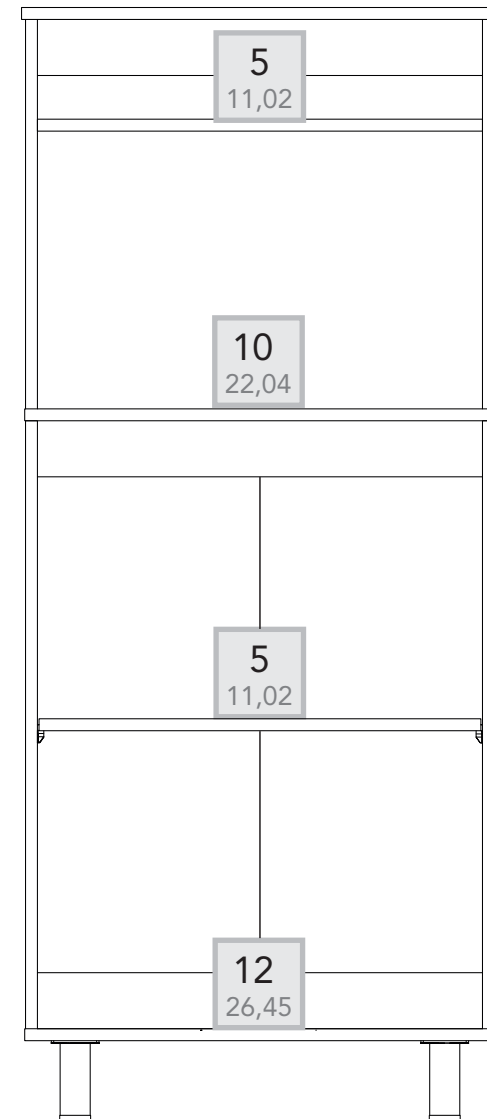

*Peso en Kg / Weight in Kg.

*Peso en Libras / Weight in Lb

Piezas de Armado / Assembly Parts

A - x1
B - x1
C - x1
D - x1
E - x1
F - x1
G - x1
H - x1
I - x1
J - x1
K - x1
L - x1
M - x1
N - x2
O - x1

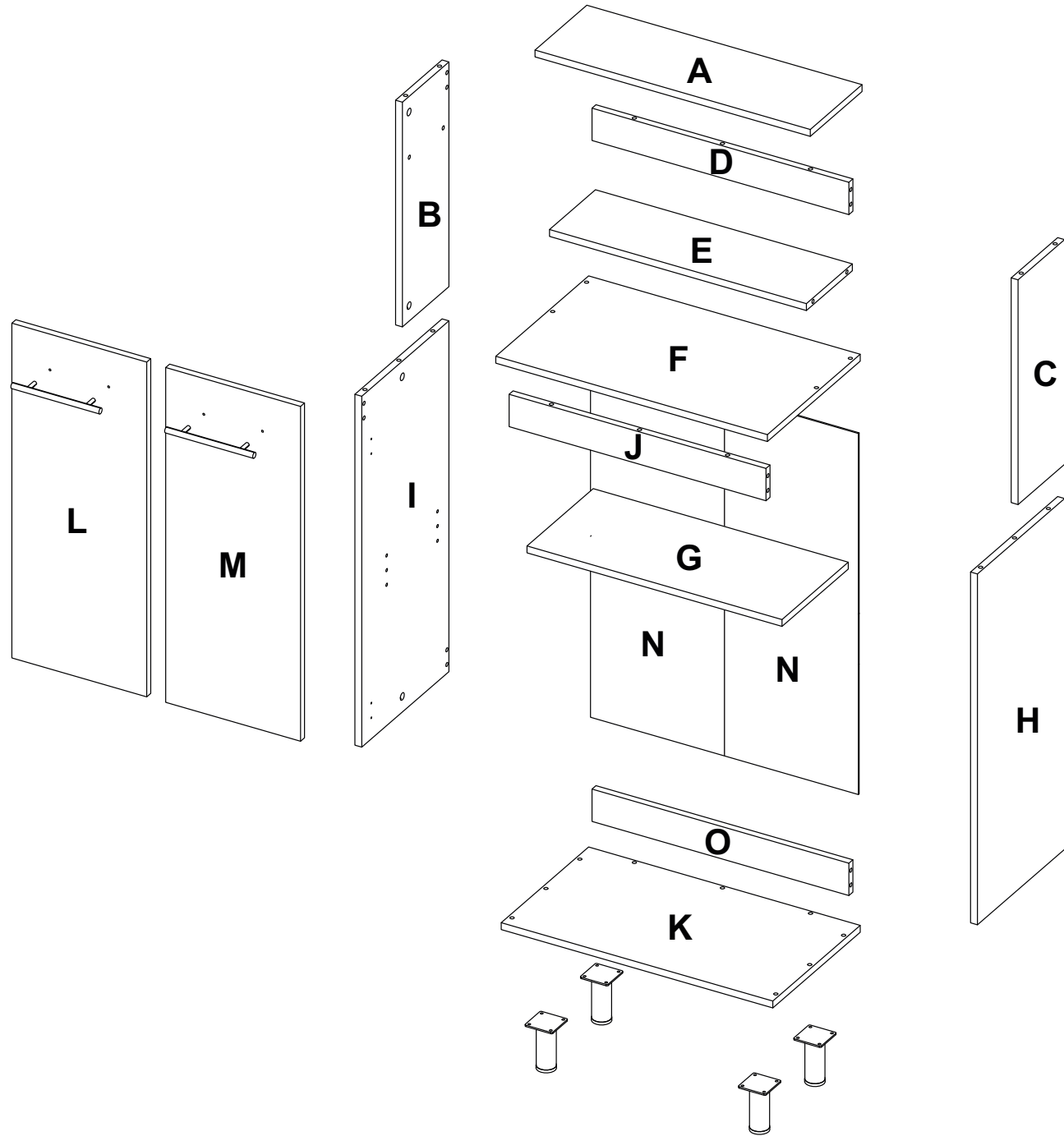

1

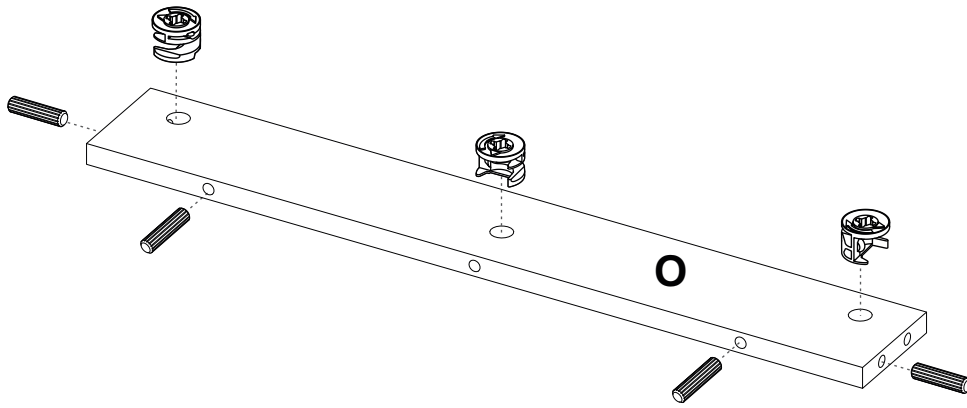

2

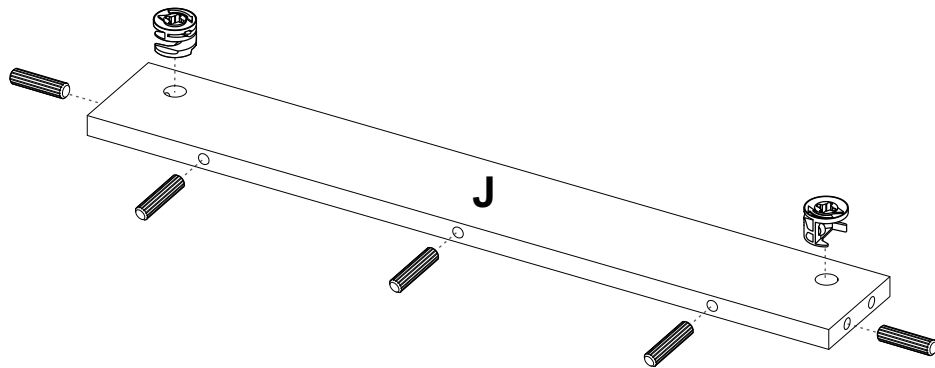

3

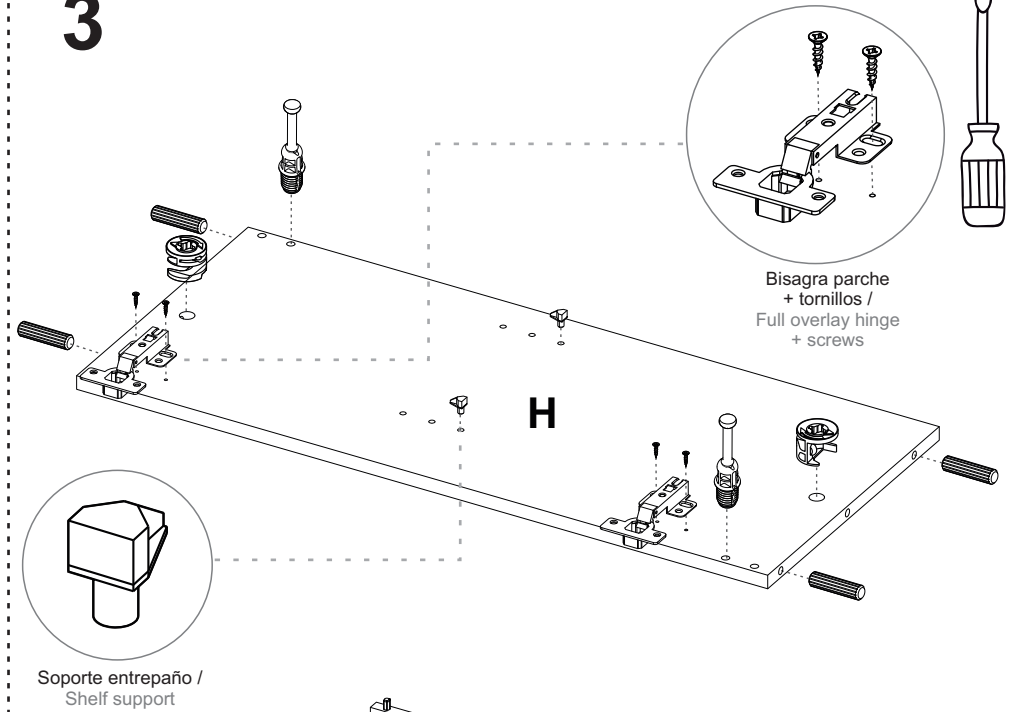

4

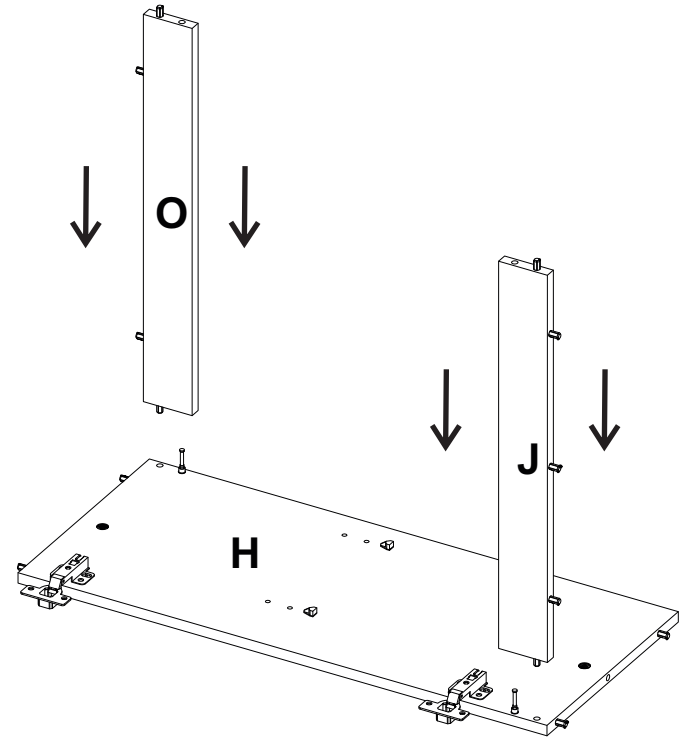

5

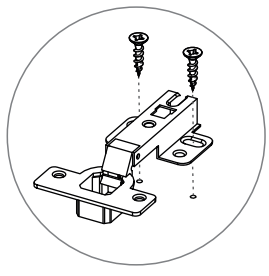

Bisagra parche
+ tornillos /
Full overlay hinge
+ screws

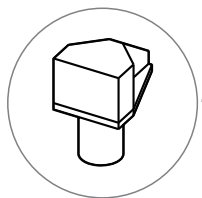
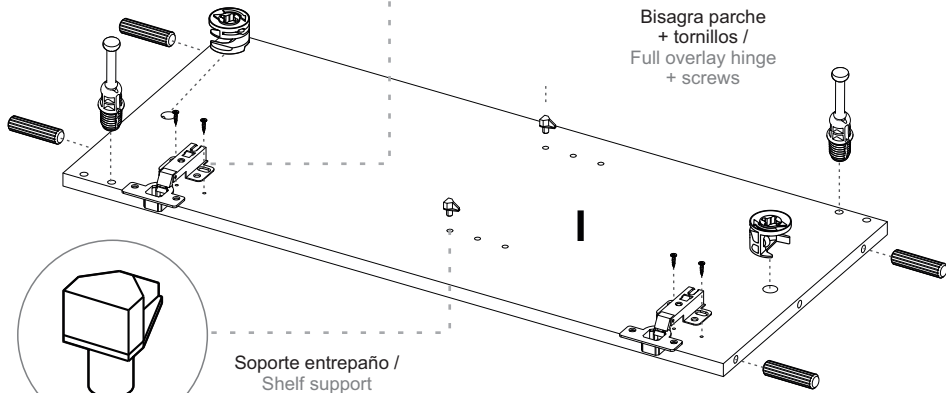

Soporte entrepaño /
Shelf support

6

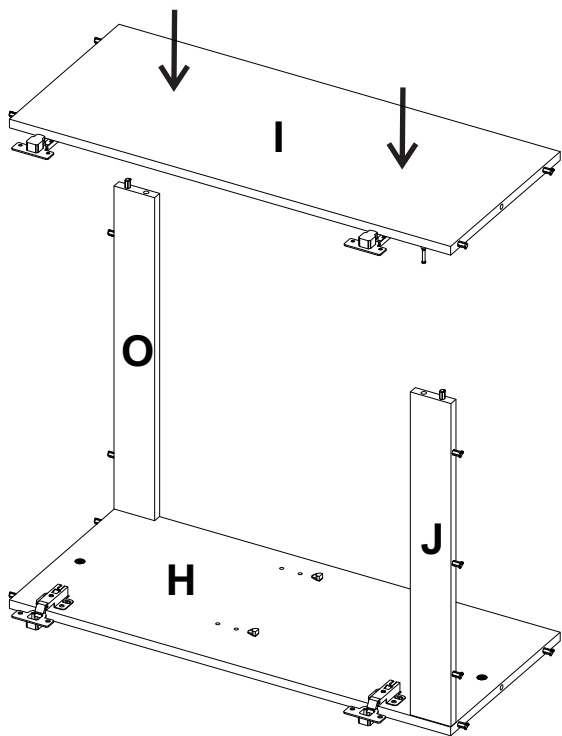

7

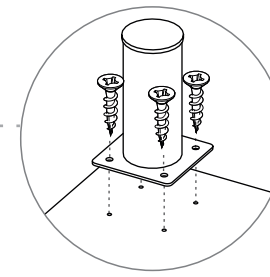

Pata de Acero /
Steel Leg



Tornillo
Lámina /
Flat Head
Screw

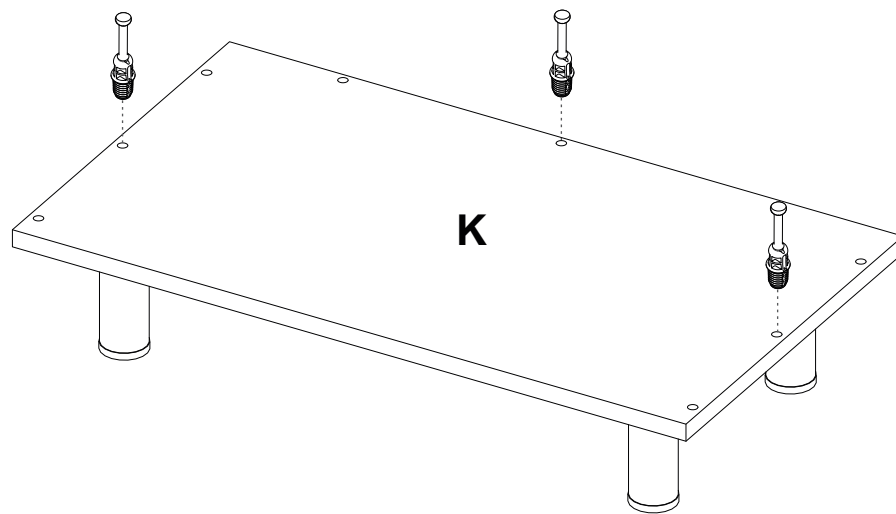
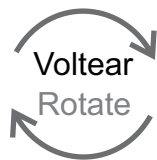
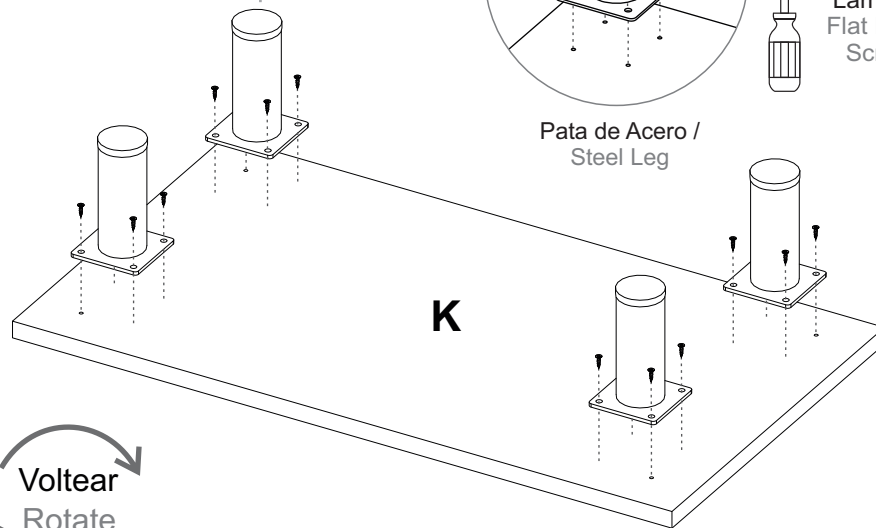

8

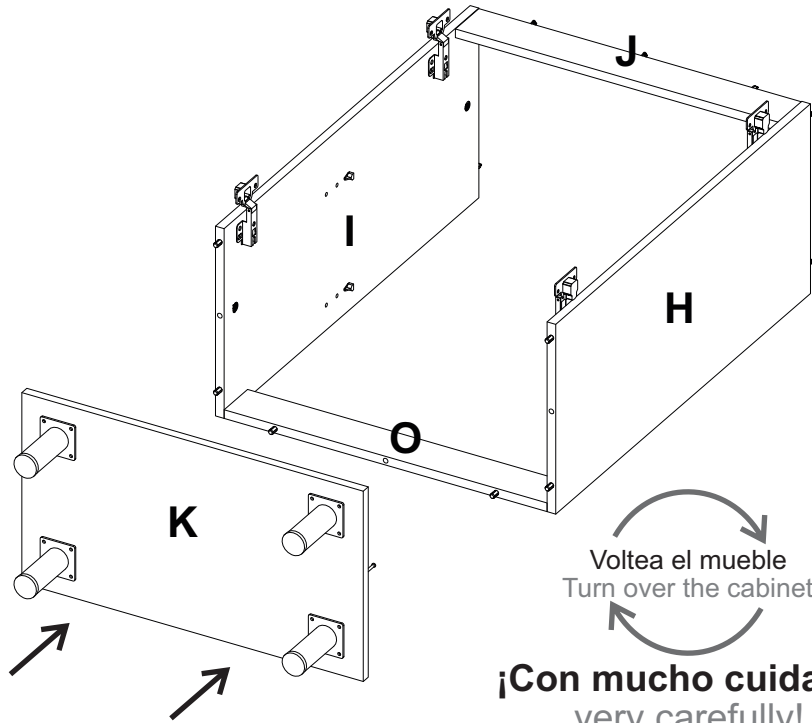

Voltea el mueble
Turn over the cabinet

¡Con mucho cuidado!
very carefully!

9

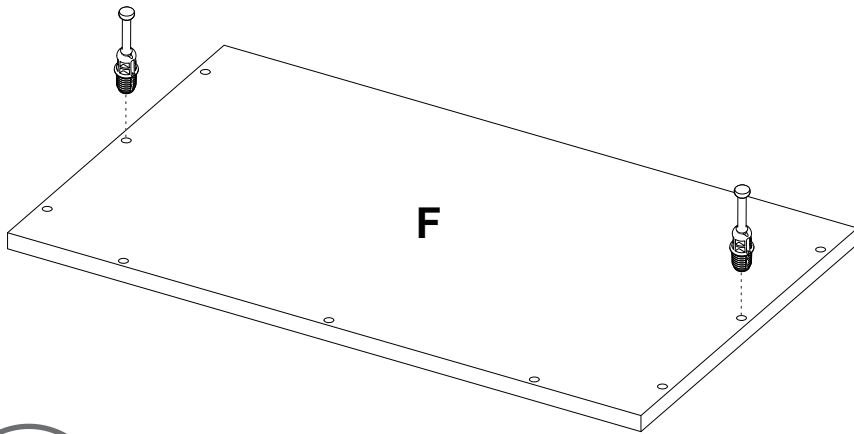

Voltear
Rotate

10

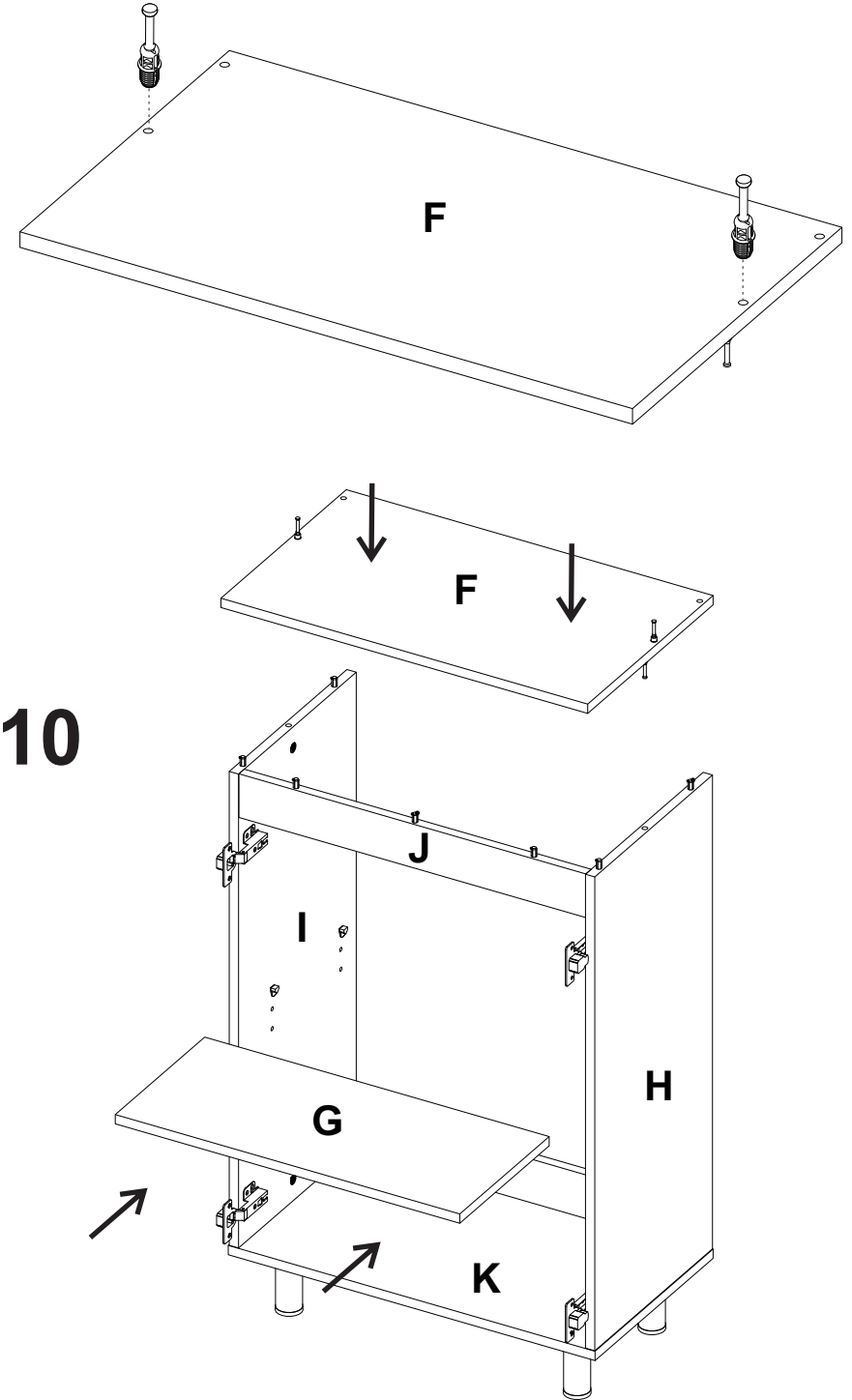

11

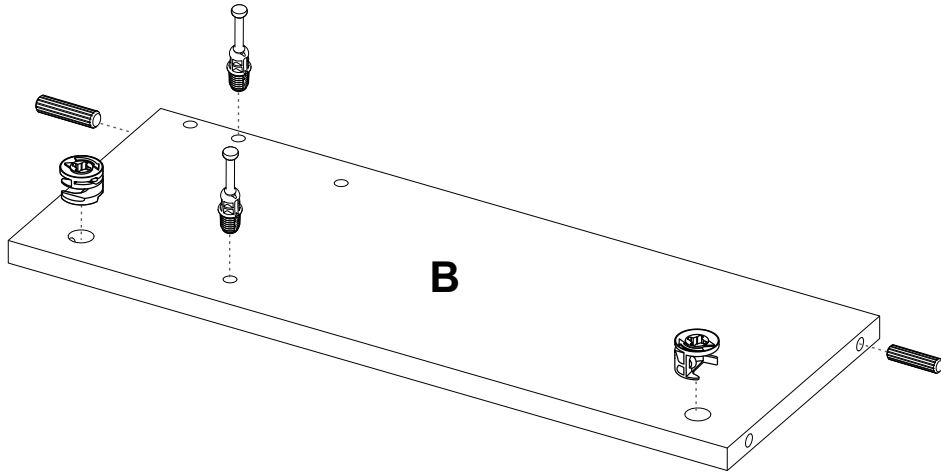

13

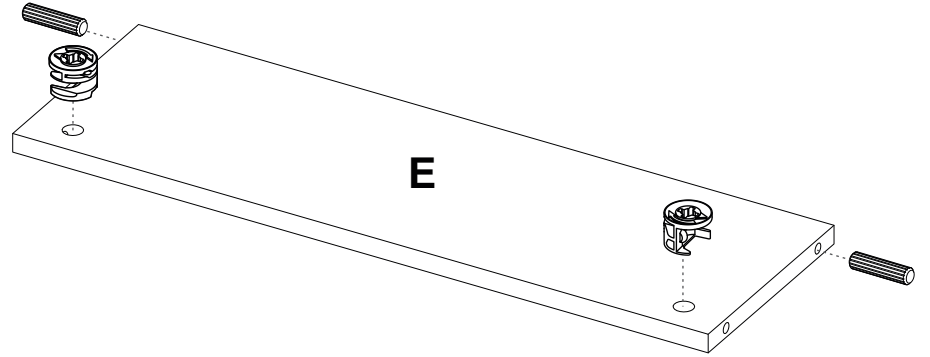

12

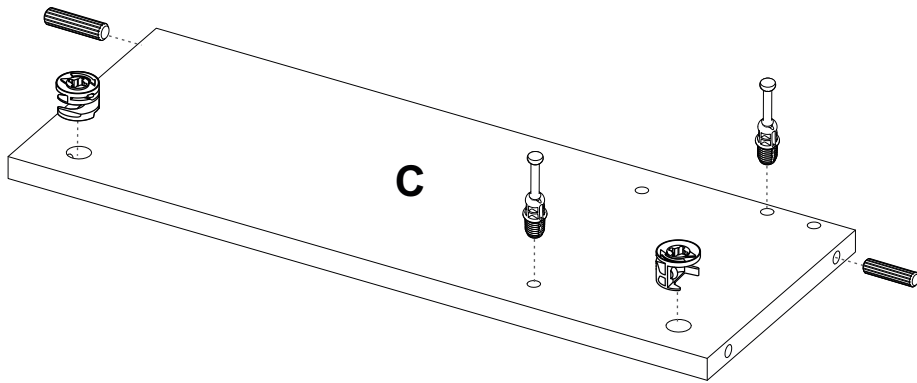

14

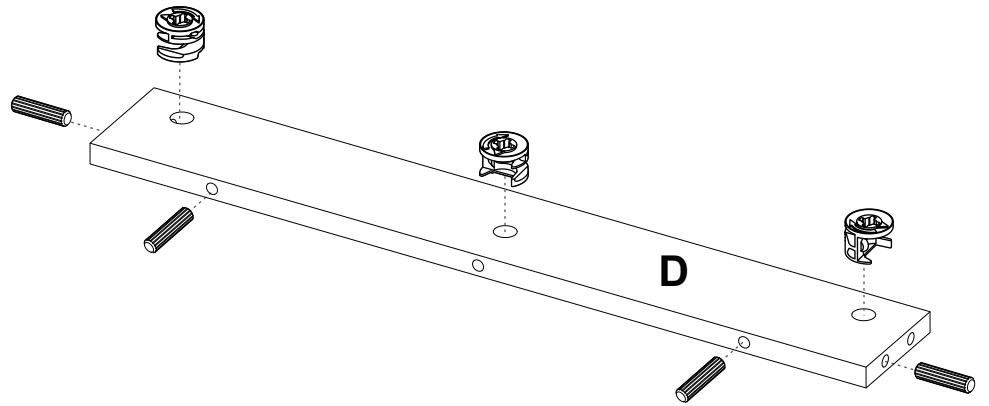

15

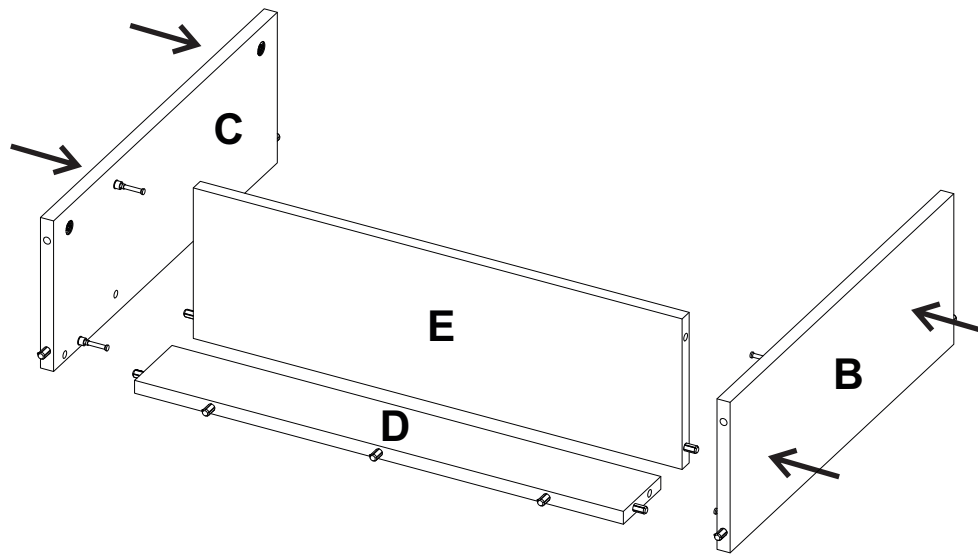

16

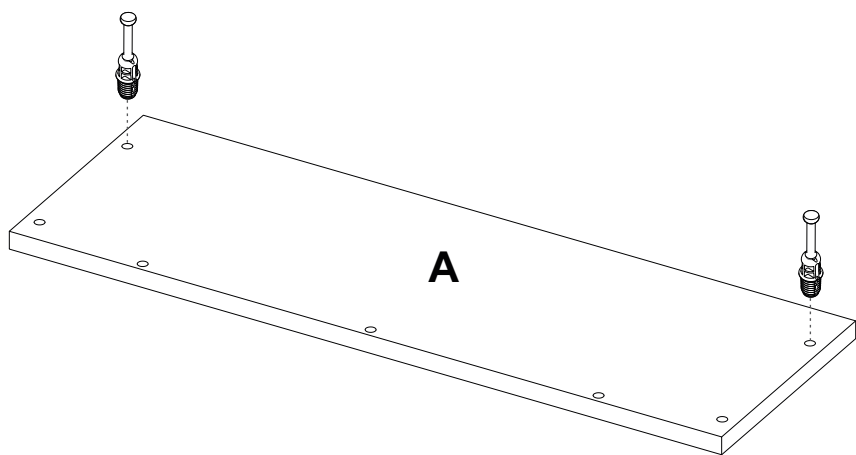

17

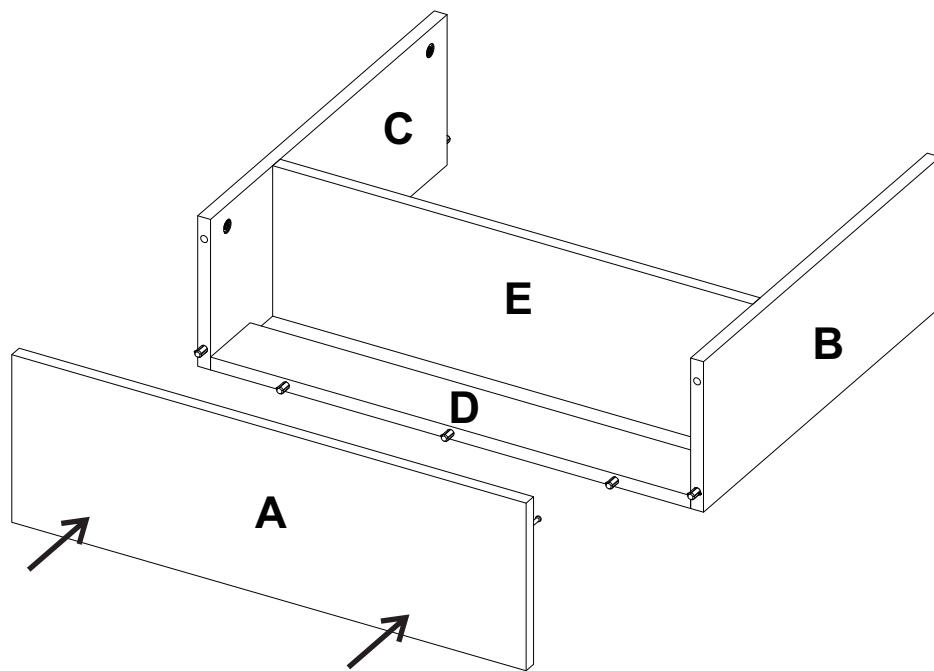

18

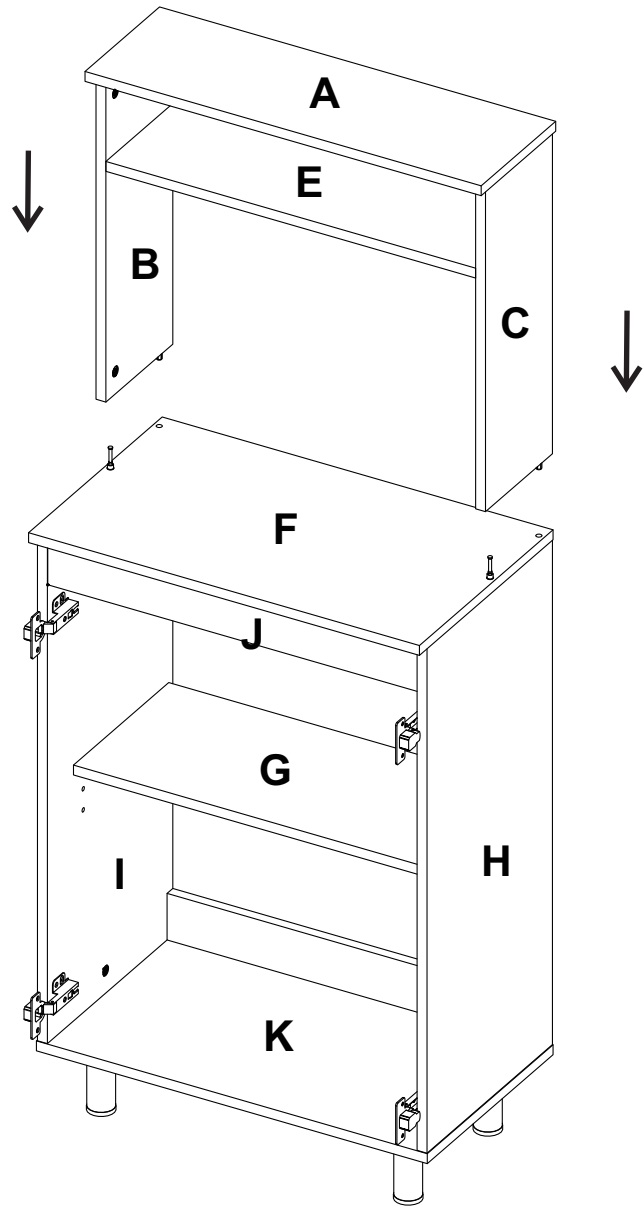

19

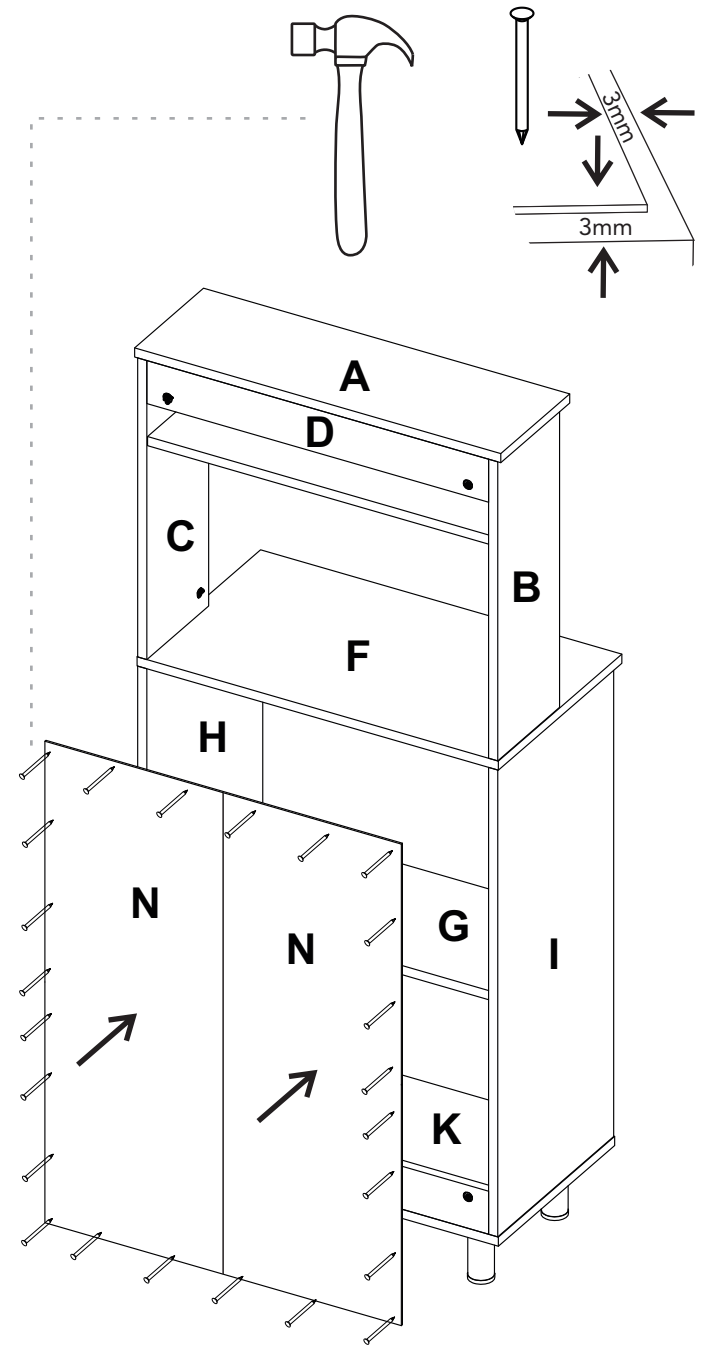

20

Instalación de la puerta Door Installation

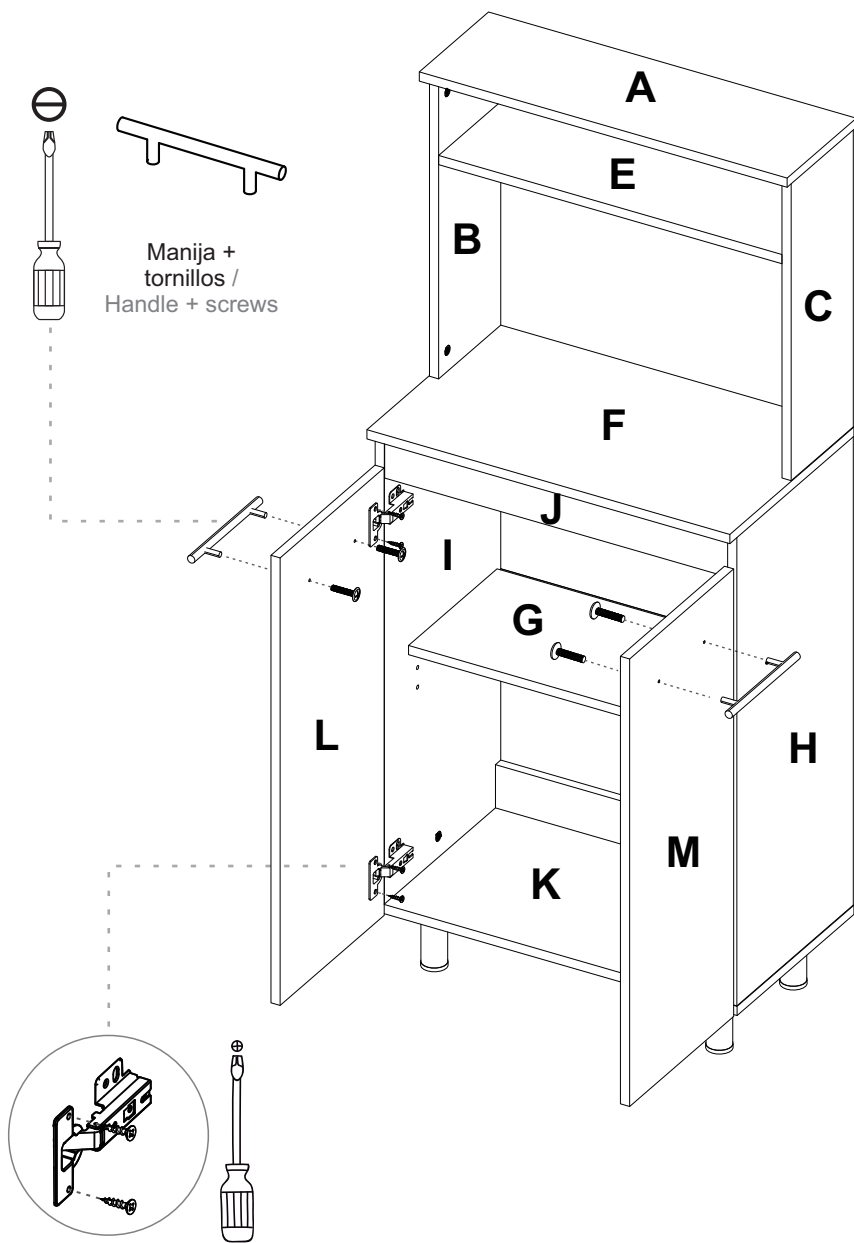

21

Ajuste de las bisagras Hinge adjustment

