

25

INSTALACIÓN DE LAS PUERTAS
DOOR INSTALLATION

Ubicar el entrepaño móvil /
Place the mobile shelf

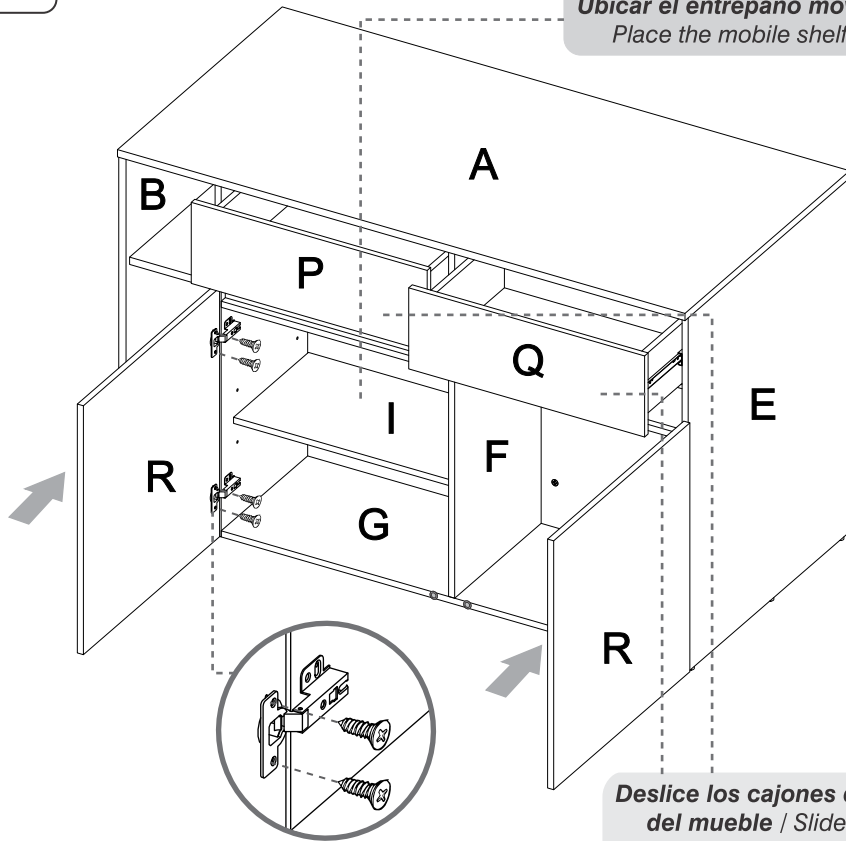

Deslice los cajones dentro
del mueble / Slide the
drawers inside the cabinet

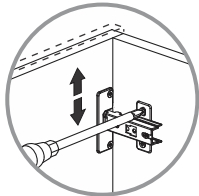

AJUSTE DE ALTURA
| HEIGHT
ADJUSTMENT

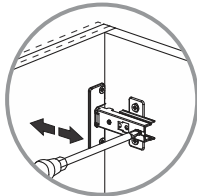

AJUSTE DE PROFUNDIDAD
| DEPTH
ADJUSTMENT

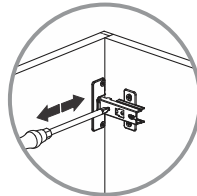

AJUSTE LATERAL
| LATERAL
ADJUSTMENT



Al finalizar el ajuste, cubra las cajas con las tapas adhesivas / After tightening all the panels, cover the minifix cams with the adhesive caps.



Al terminar de armar, despegue los adhesivos (en caso de que queden residuos de pegamento, limpie la superficie con alcohol) / After finishing the assembly, take off the adhesives. (In case of glue residues, wipe them with alcohol)

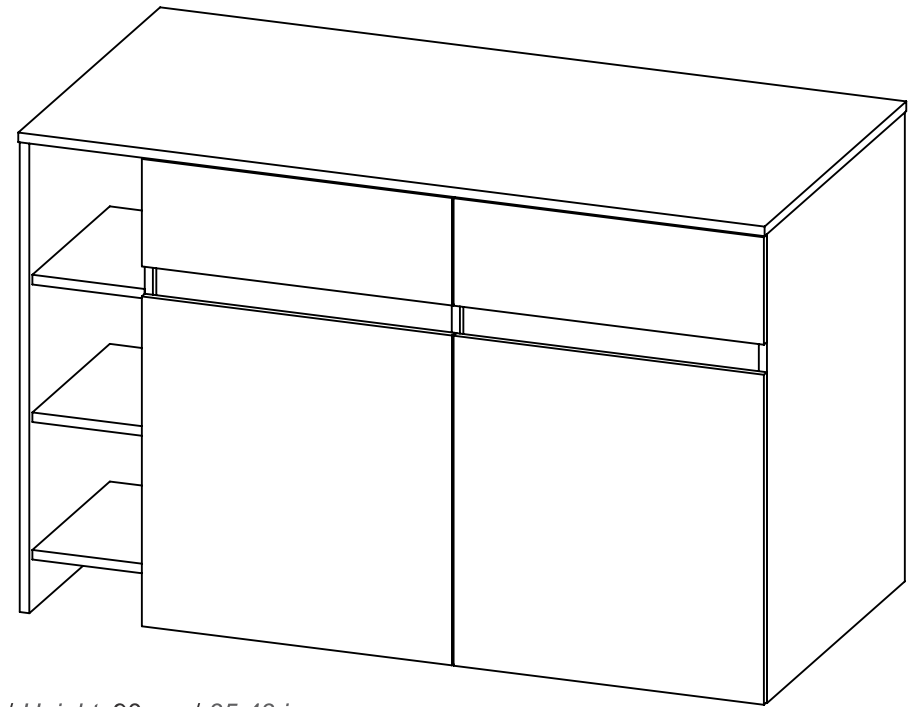

Alto/ Height: 90 cm / 35,43 in
Ancho/ Width: 140 cm / 55,12 in
Fondo/ Depth: 70,4 cm / 27,71 in

LOTE No: _____

By: RTA® TEL (572) 691 17 00
m u e b l e s PBX (572) 695 91 81
CALI - COLOMBIA
www.rta.com.co

BARRA BARI
/Bari Kitchen Bar Table

RECOMENDACIONES IMPORTANTES KEY RECOMMENDATIONS

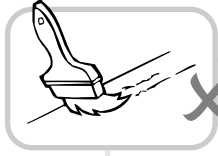

NO pinte el mueble /
Do not paint the
furniture.



NO mojar o ubicar
a la intemperie /
Do not expose to rain
or direct sun.

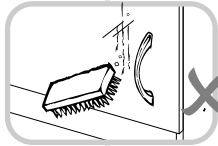
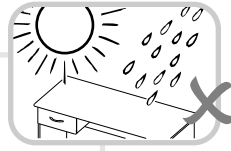

NO lavar las manijas o
tiraderas con jabones o
elementos abrasivos /
Do not wash handles
or knobs with soap or
abrasives.

NO sobrecargue el mueble.
no exceda el peso de 30 kilos
para gabinetes de cocina /
Do not overload the cabinet.
Weight max. 66lbs
for kitchen cabinets.

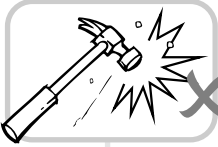

NO golpear ni martillar
el mueble (hágalo sólo
donde se indique) /
Do not hit or hammer
the furniture (just do it
where is indicated).

NO permita que los niños
manipulen el mueble, puede
voltearse y lastimarnos /
Do not allow children to
handle the cabinets or
drawers, they could get hurt.



SIEMPRE levante el
mueble entre dos
personas, NO lo arrastre /
Do not drag the furniture.
Lift it between two people.

Limpie con paño seco,
/ Clean with a dry cloth.



HERRAJES BÁSICOS PARA MUEBLES HC BASIC HARDWARE FOR HC FURNITURE

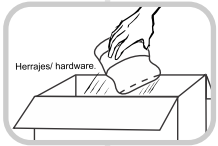

1. Abrir la caja del mueble
y buscar la bolsa con los
herrajes / Open the box
and look for the hardware
bag.

3. Separe los herrajes para
facilitar su identificación
durante el armado /
Separate hardware for easy
identification during
assembly.

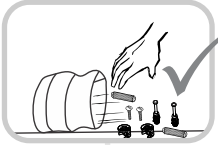
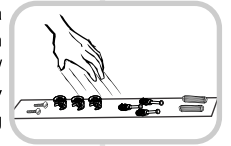

2. Abrir el paquete y
comprobar que el
contenido de las piezas es
correcto / Open the
package and verify that
the content of the pieces
is correct.

4. Arme el mueble en un lugar
limpio y en una superficie
plana / RTA furniture
must be assembled
in a clean place and on
a flat surface.

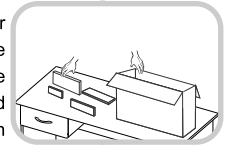

23

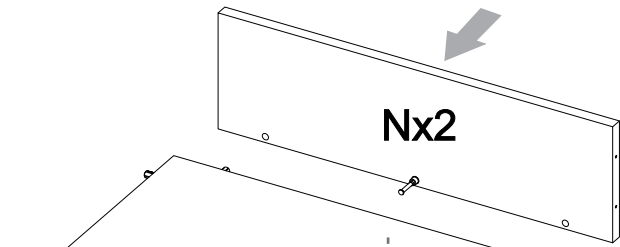

Nx2

Ox2

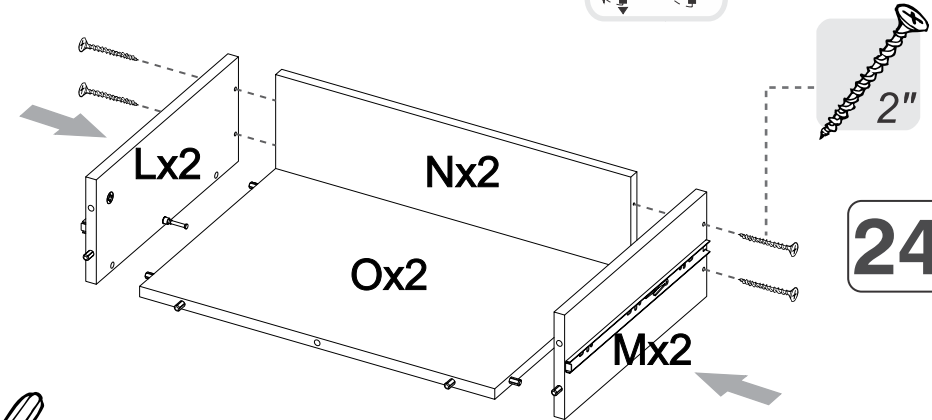
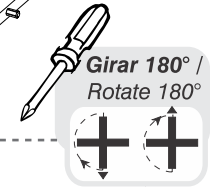

Lx2

Nx2

Ox2

Mx2

24

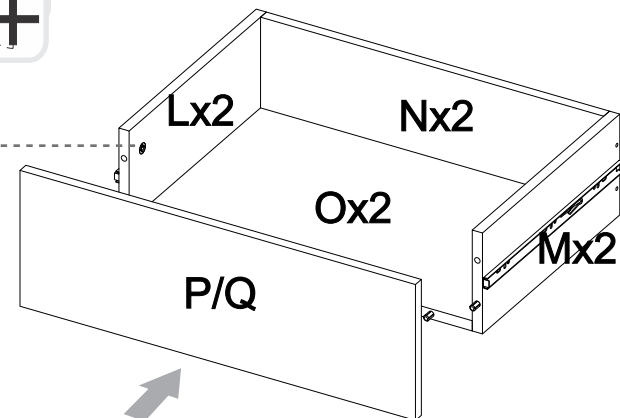
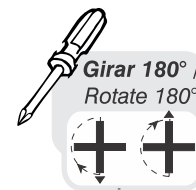

Lx2

Nx2

Ox2

Mx2

P/Q

21

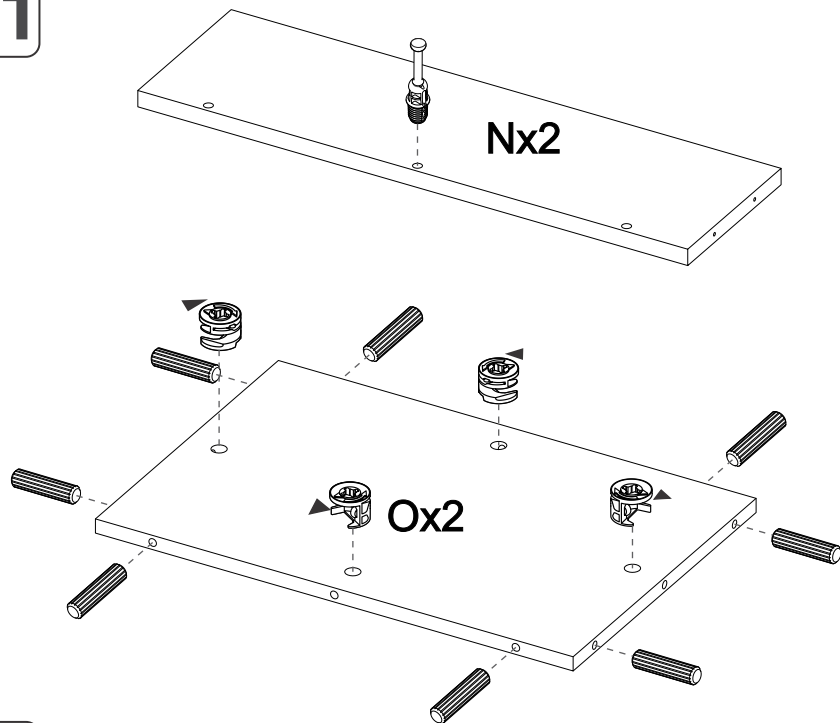

22

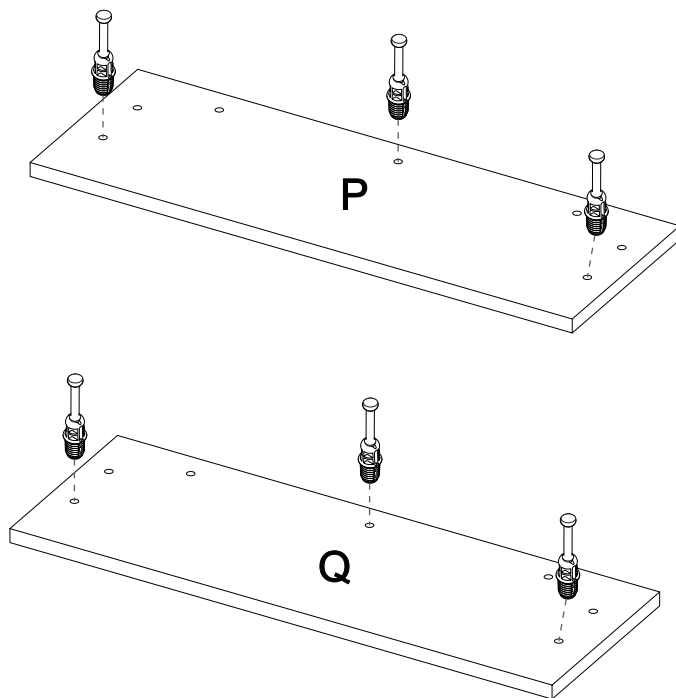

RECOMENDACIONES DE ENSAMBLE / ASSEMBLY RECOMMENDATIONS

El buen funcionamiento del mueble depende de un adecuado ensamblaje
An excellent furniture's performance relies on a solid and a suitable assembly.

MINIFIX / CONNECTOR - DOWELS

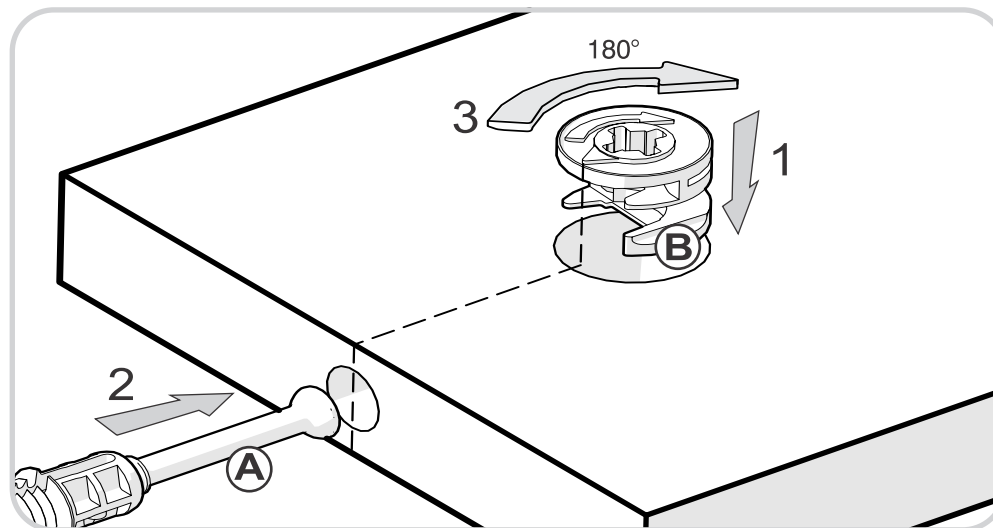

Sistema de unión compuesto por un perno (A) y una caja minifix (B).

(1) Se inserta la caja minifix dentro de la perforación ubicada en la cara de la pieza, la flecha debe apuntar siempre a la dirección de la perforación por donde entrará el perno.

(2) Se debe insertar el perno por su parte plástica en las perforaciones que se indiquen, luego se inserta la punta metálica en la perforación para que su cabeza quede al interior de la caja minifix.

(3) Girar la caja minifix 180° para apretar las dos piezas.

It's a fitting system made of a spreading bolt (A) and a minifix cam (B).

(1) Insert the minifix cam in the hole placed in the face of the panel with the arrow pointing towards the hole where the bolt will fit.

(2) Insert the bolt with its plastic base in the shown holes, then insert the metallic bolt head in the holes so it fits inside the minifix cam.

(3) Tight the panels by turning the minifix cam 180°.

TARUGOS O TAQUETES / FLUTED DOWEL PIN

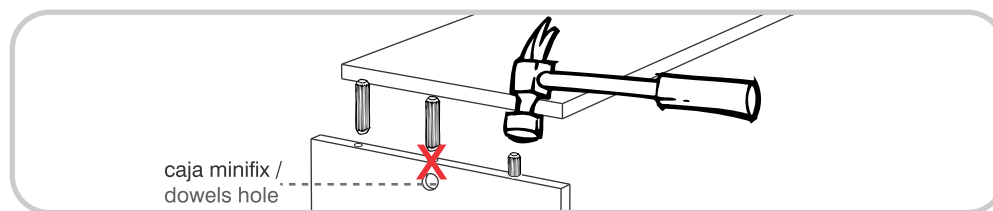

Es un pedazo de madera corto y grueso, de aproximadamente 3 a 10 cm de largo, que sirve para amarrar el mueble y darle resistencia.

It's a short and thick piece of wood, 1,18 to 3,9 inches approximately, which is used to tie the cabinet and give it resistance.

RECOMENDACIONES IMPORTANTES / KEY RECOMMENDATIONS

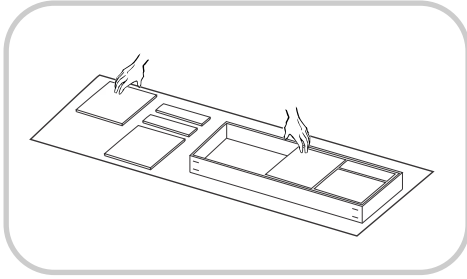

Se recomienda armar el mueble sobre la caja o una superficie lisa para no rayarlo. It is recommended to assemble the product on the box or on a flat surface to not scratch it.

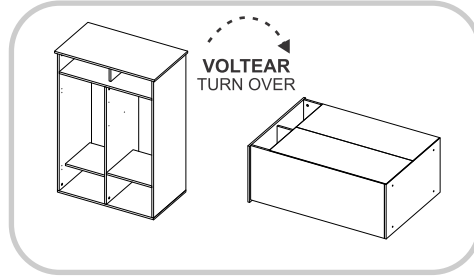

Voltear el mueble cuidadosamente para ensamblar los fondos. Carefully turn over the cabinet to assemble the back panels.

PESO MAX. SUGERIDO EN MUEBLE (Kg) / MAX SUGGESTED LOAD (Kg)

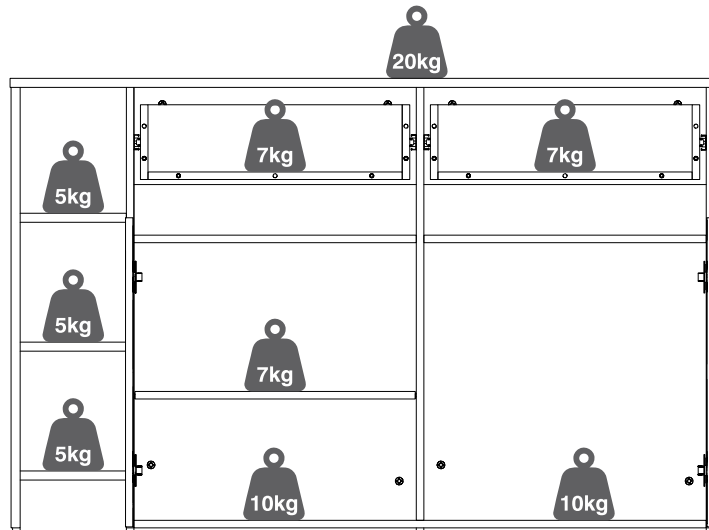

NOTA: La resistencia a las cargas puede variar dependiendo si es una carga distribuida o una carga puntual, las gráficas corresponden a cargas puntuales, NO exceder los pesos sugeridos / **NOTE:** The load capacity depends if it is a point load or if it is an uniform distributed load, do not exceed the suggested loads.

19

VOLTEAR
TURN OVER

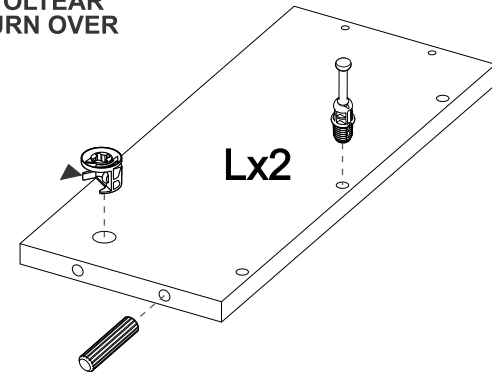

PARA PONER RIEL EN LATERAL DEL CAJÓN/
When placing the slide on the side of the drawer:

Revisar que el tope metálico del riel quede en la PARTE DELANTERA/
The metallic stop should be placed on the front.

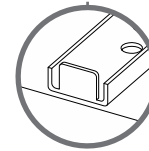

Mx2

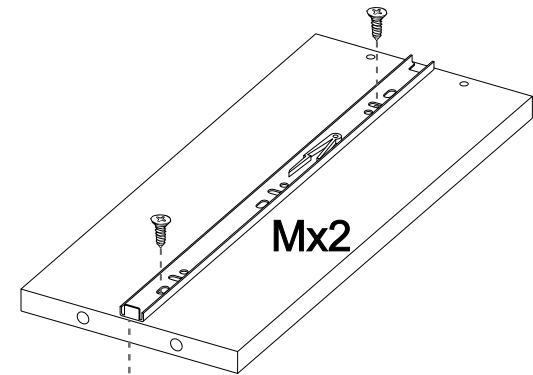

VOLTEAR
TURN OVER

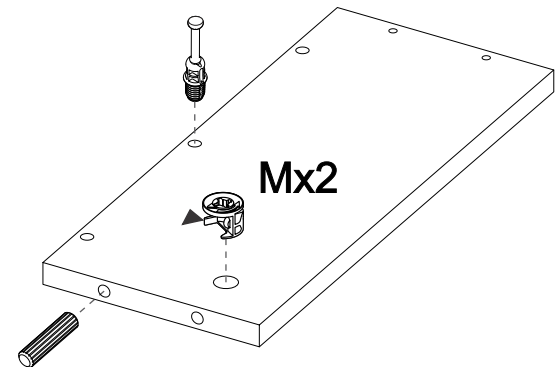

20

17

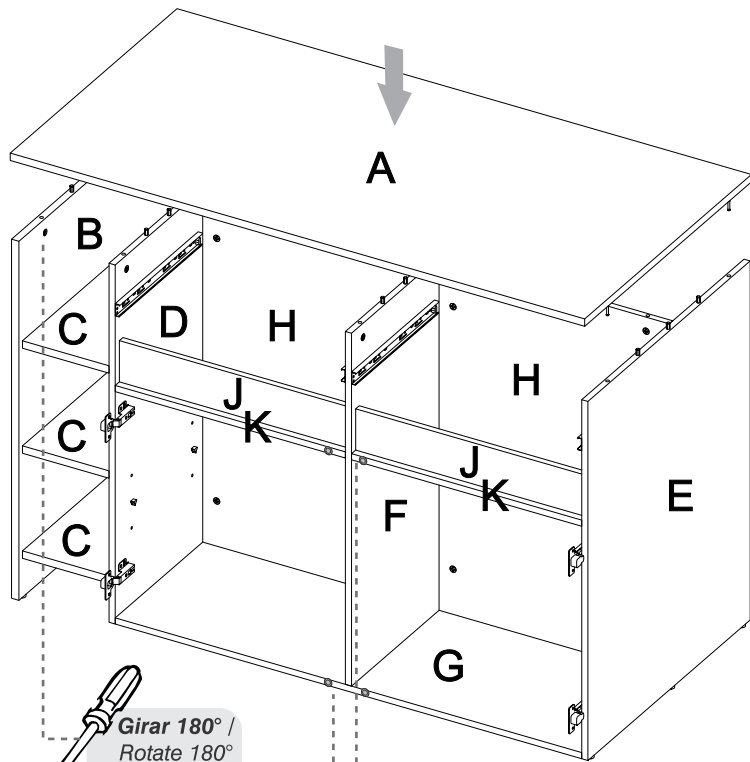

18

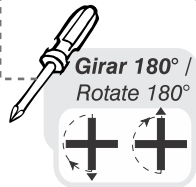

x4  **Topes Burbuja/**
Soft Close
Bumper Stops

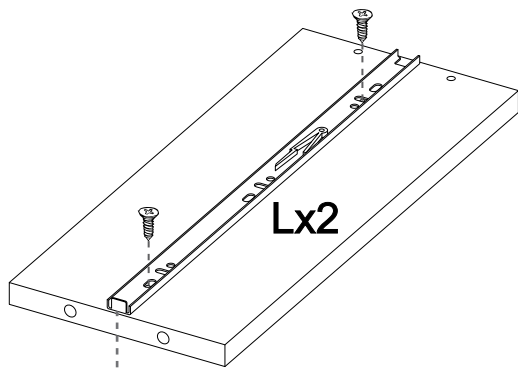

PARA PONER RIEL EN LATERAL DEL CAJÓN/
When placing the slide on the side of the drawer:

Revisar que el **tope metálico** del riel quede en la **PARTE DELANTERA**!
The metallic stop should be placed on the front.

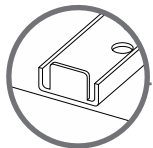

HERRAJES PARA ARMADO ASSEMBLY HARDWARE

x60

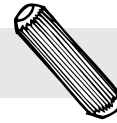

Tarugo/
Fluted Dowel Pin

x56

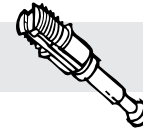

Perno minifix/
Spreading Bolt

x56



Minifix/
Minifix Cams

x48



Tapa Adhesiva
Minifix/
Cover Caps
COLOR 1

x14



Tapa Adhesiva
Minifix/
Cover Caps
COLOR 2

x10



Deslizador/
Nail-On Glide

x4

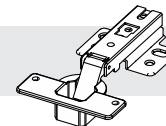

Bisagra Parche/
Full Overlay Hinge

x2

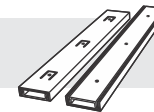

Riel Extension
Total/ Full Extension
Drawer Slides

x26



Tornillo de
Ensamble 2"/
2" Drywall Screw

x40



Tornillo Lámina/
Sheet Screw

x4



Soporte entrepaño
movil/ Mobile
shelf support

x4



Tope Burbuja/
Soft Close
Bumper Stops



TENER PRECAUCIÓN AL ABRIR LA BOLSA DE HERRAJES PARA NO EXTRAVIAR NINGUNO. COMPRUEBE QUE EL CONTENIDO DE LAS PIEZAS SEA EL CORRECTO. EN CASO QUE FALTE ALGUNA PIEZA O ESTE DEFECTUOSA DEVUELVA LAS PIEZAS AL ALMACÉN CON SU FACTURA PARA EFECTUAR EL CAMBIO DE LAS PIEZAS Y/O LOS HERRAJES LO MÁS PRONTO POSIBLE. / PLEASE BE CAUTIOUS WHEN OPENING THE HARDWARE BAG TO NOT LOSE ANY. CHECK THE CONTENTS OF THE PARTS ARE CORRECT. IF ANY PART IS MISSING OR IMPERFECT PLEASE RETURN THE PARTS TO THE STORE WITH THE PRODUCT INVOICE ATTACHED TO MAKE EFFECTIVE THE REPLACEMENT OF THE IMPERFECT PIECES OR HARDWARE AS SOON AS POSSIBLE.

PIEZAS DE ARMADO
ASSEMBLY PARTS

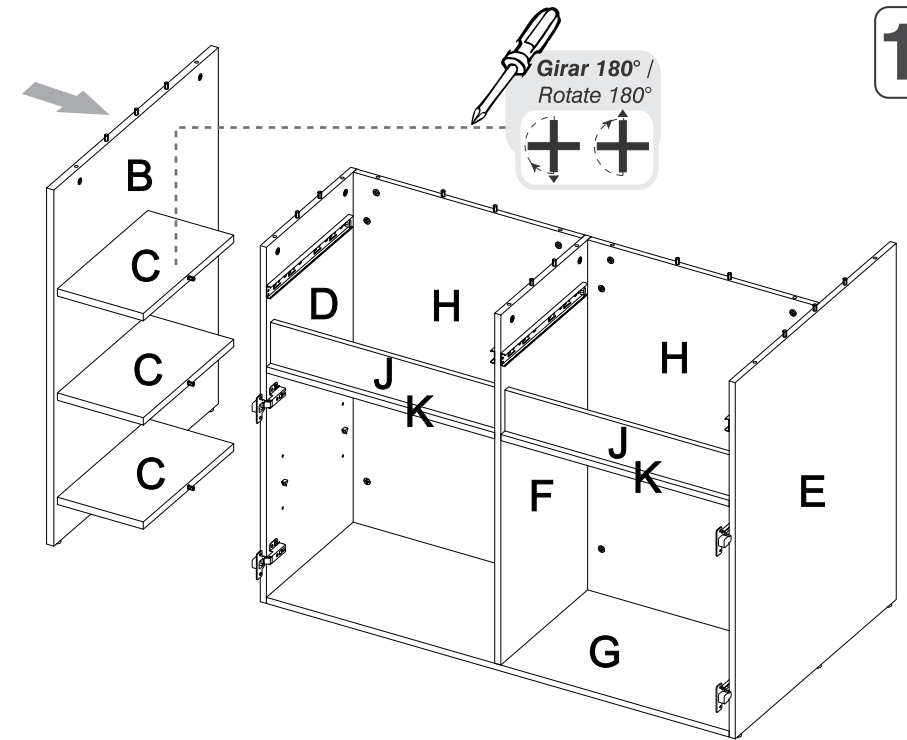
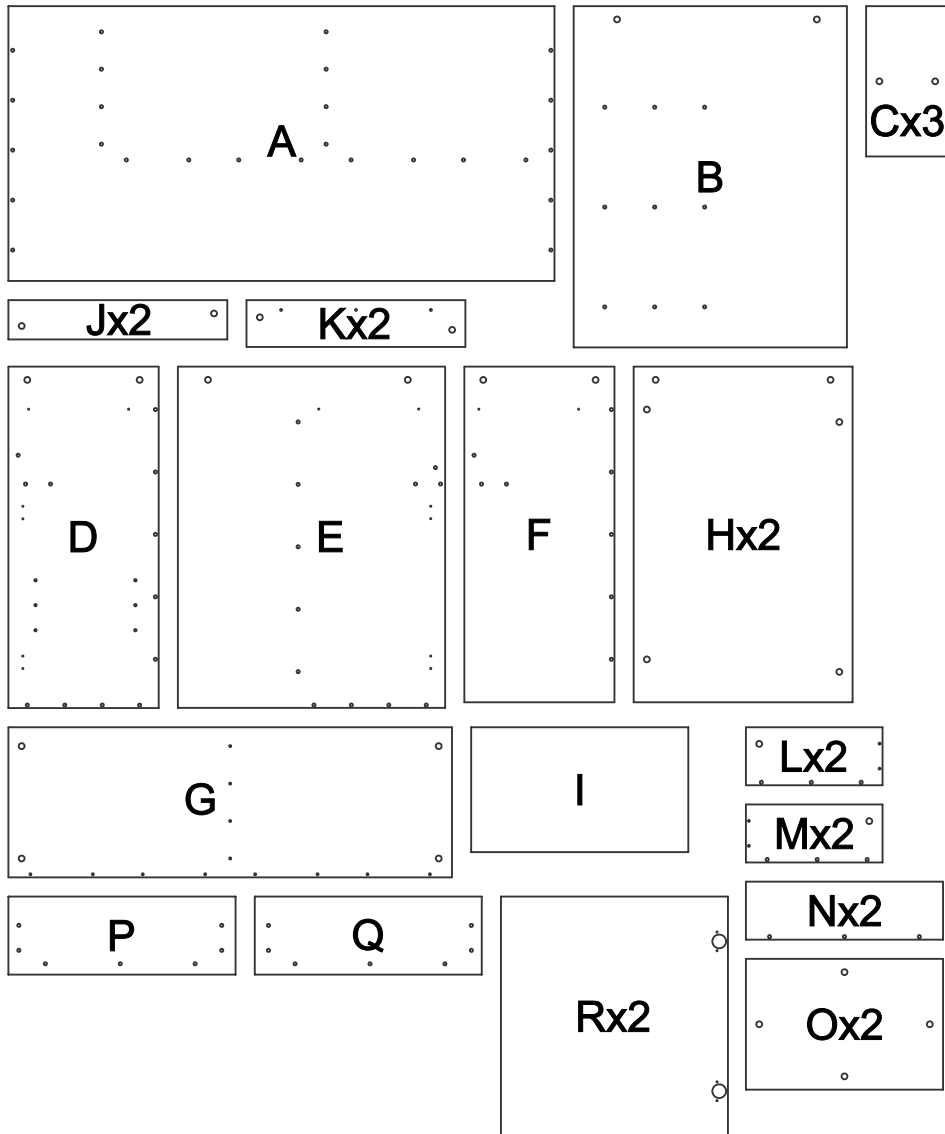

15

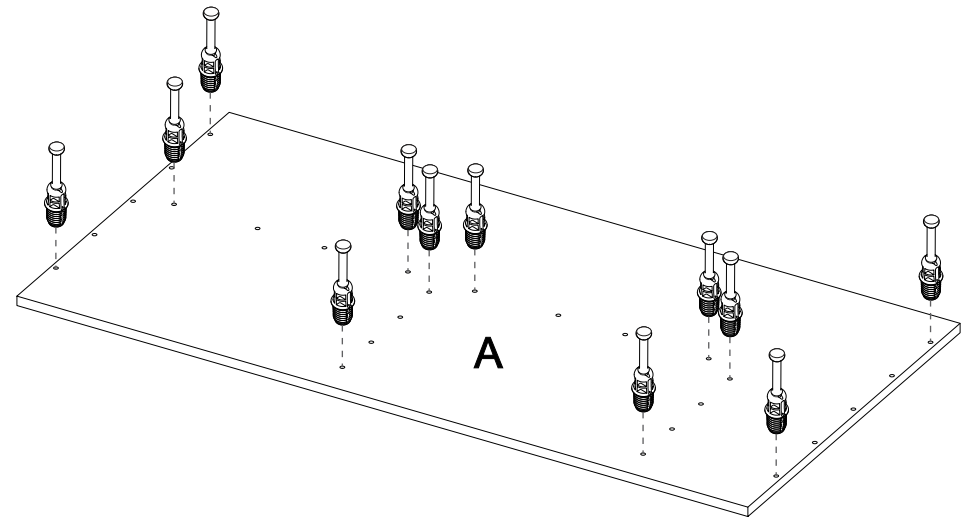

16



ANTES DE EMPEZAR A ARMAR EL MUEBLE LEA DETENIDAMENTE LAS INSTRUCCIONES. SE RECOMIENDA ARMAR EL MUEBLE SOBRE LA CAJA O SOBRE UNA SUPERFICIE LISA Y CUBIERTA, PARA NO RAYARLO / BEFORE STARTING TO ASSEMBLE THE CABINET, CAREFULLY READ THE INSTRUCTIONS. IT IS RECOMMENDED TO ASSEMBLE THE FURNITURE ON THE BOX OR ON A FLAT AND COVERED SURFACE IN ORDER TO NOT SCRATCH THE PRODUCT.

13

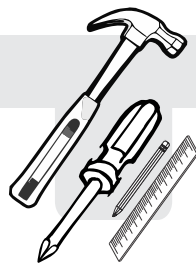
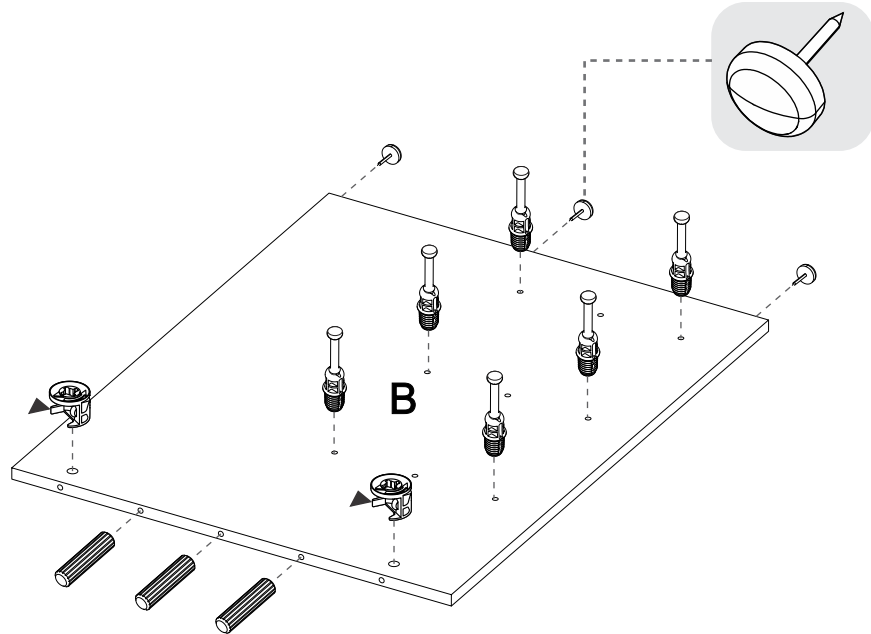

*(Herramientas NO incluidas) *Tools NOT Included

14

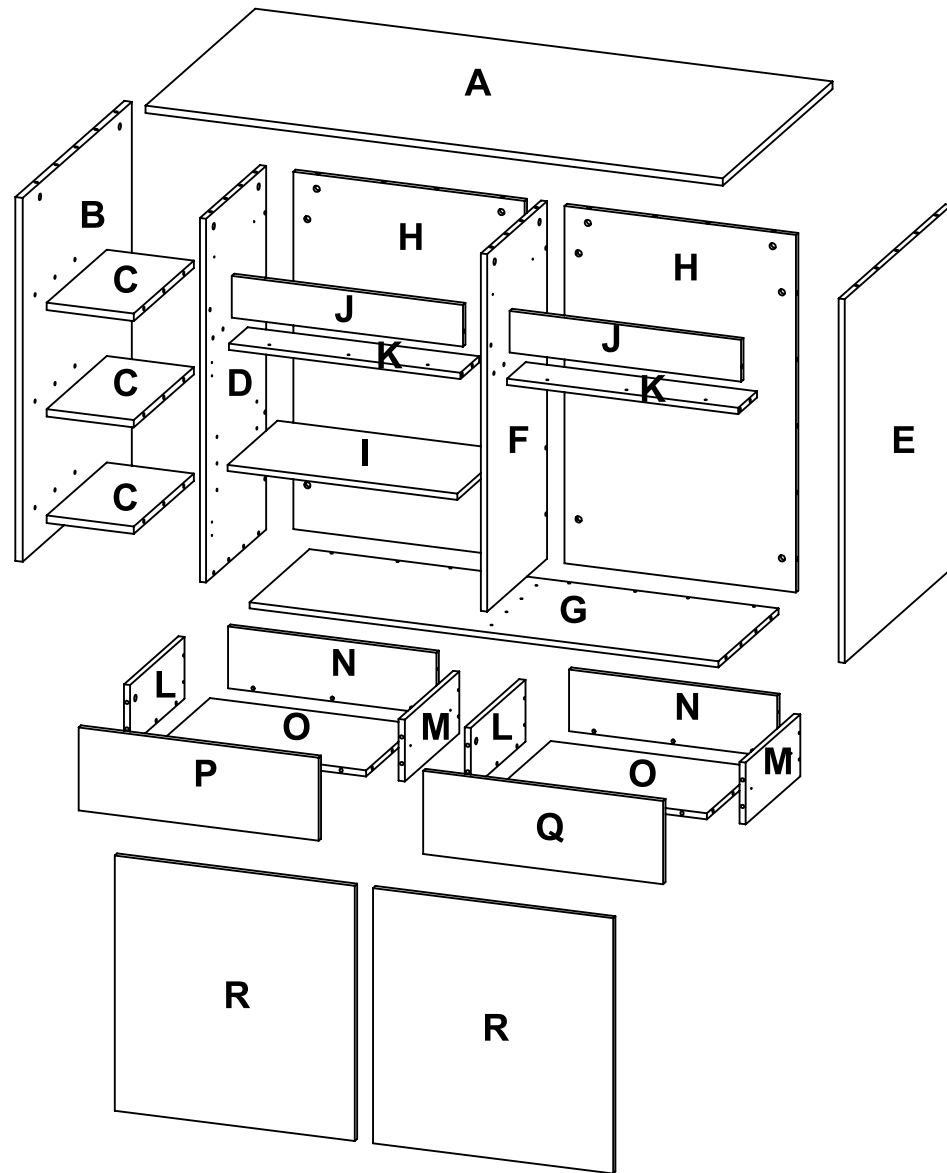
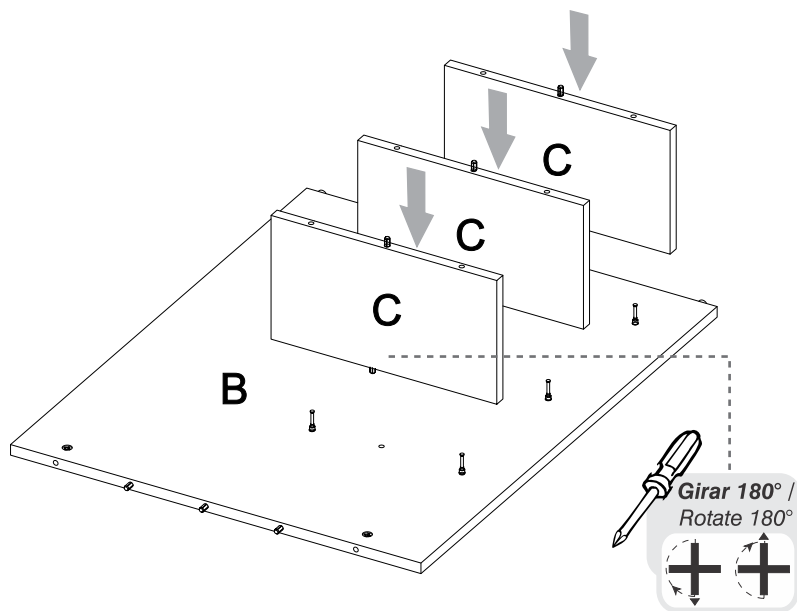

1

SE RECOMIENDA ARMAR EL MUEBLE ENTRE DOS PERSONAS / IT IS RECOMMENDED TO ASSEMBLE THE PRODUCT BETWEEN TWO PEOPLE

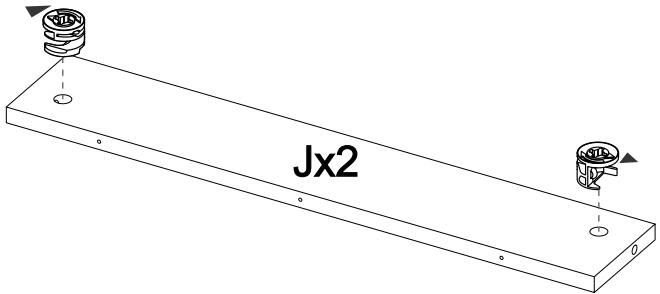

2

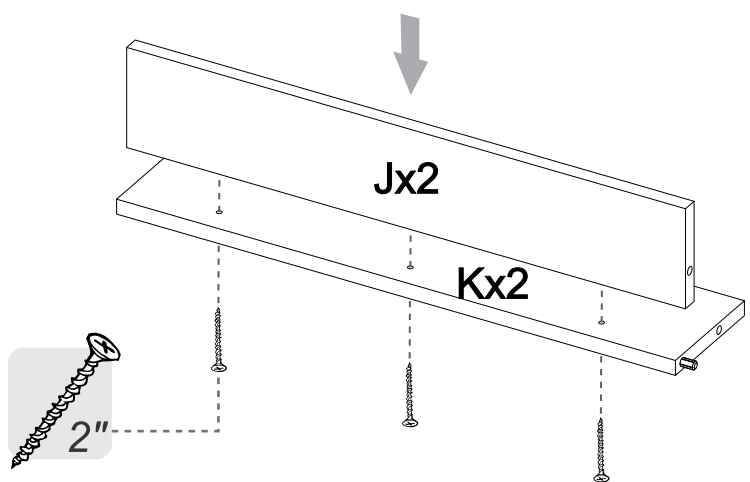
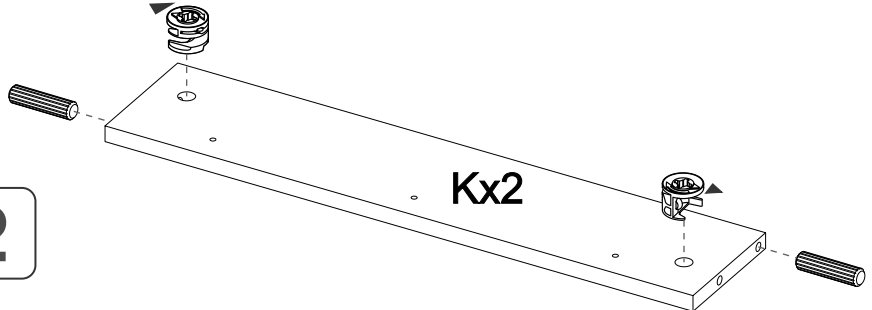

VOLTEAR EL MUEBLE CUIDADOSAMENTE / CAREFULLY FLIP THE CABINET

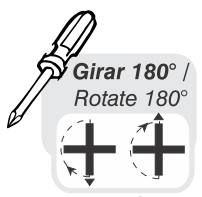

11

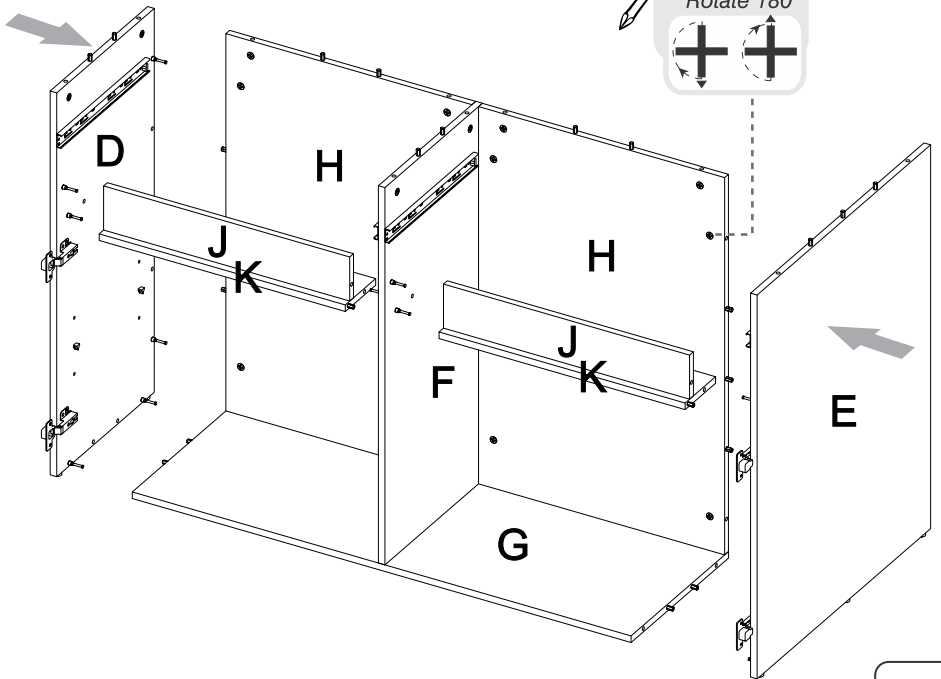

12

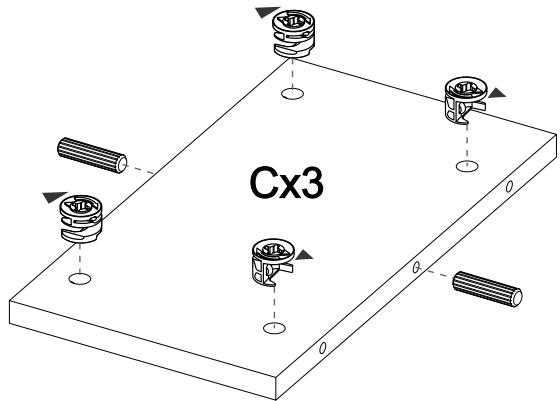

9

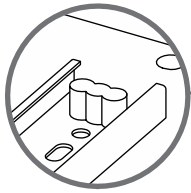

PARA PONER RIEL EN LATERAL DEL MUEBLE/ When placing the slide on the side of the Cabinet:

Revisar que el tope plástico del riel quede en la PARTE TRASERA/ The plastic stop should be placed on the rear.

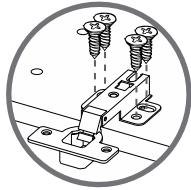

VOLTEAR TURN OVER



10

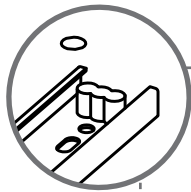

PARA PONER RIEL EN LATERAL DEL MUEBLE/ When placing the slide on the side of the Cabinet:

Revisar que el tope plástico del riel quede en la PARTE TRASERA/ The plastic stop should be placed on the rear.

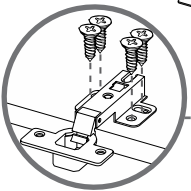

3

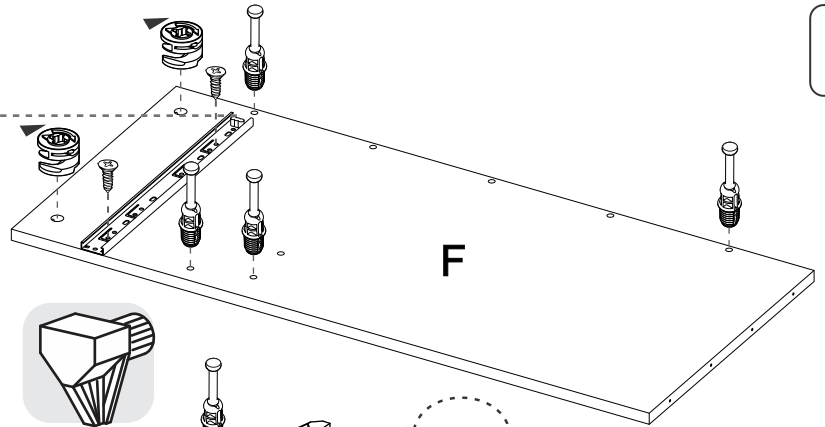

F



VOLTEAR TURN OVER

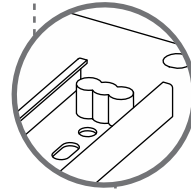

4



PARA PONER RIEL EN LATERAL DEL MUEBLE/ When placing the slide on the side of the Cabinet:

Revisar que el tope plástico del riel quede en la PARTE TRASERA/ The plastic stop should be placed on the rear.

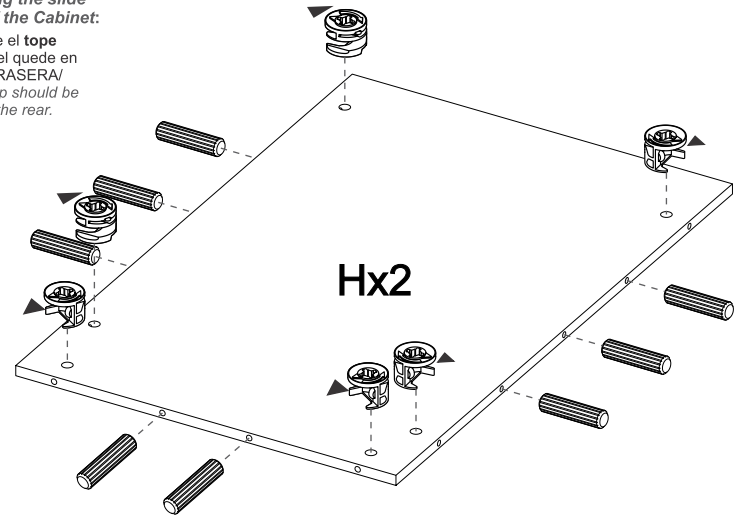

Hx2

5

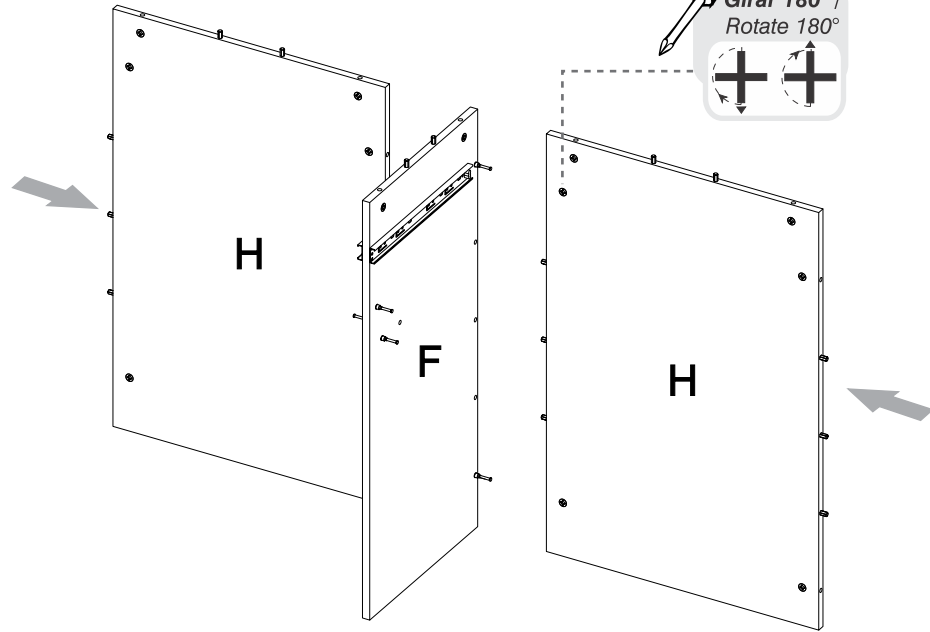

6

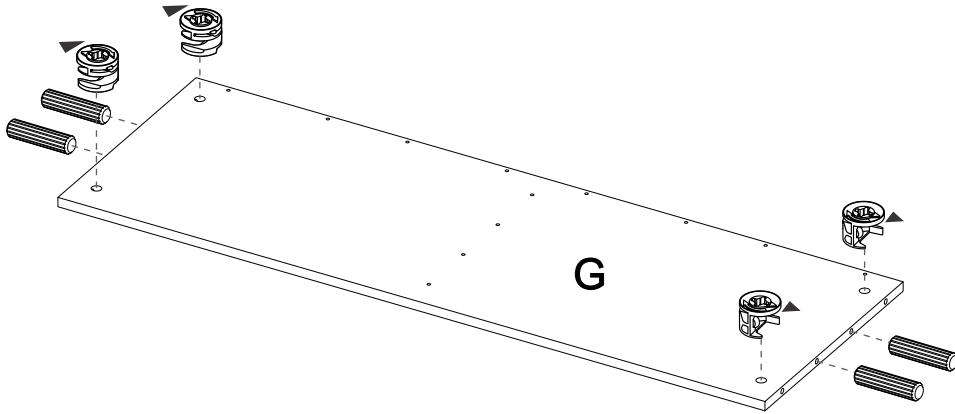

VOLTEAR EL MUEBLE CUIDADOSAMENTE / CAREFULLY FLIP THE CABINET



7

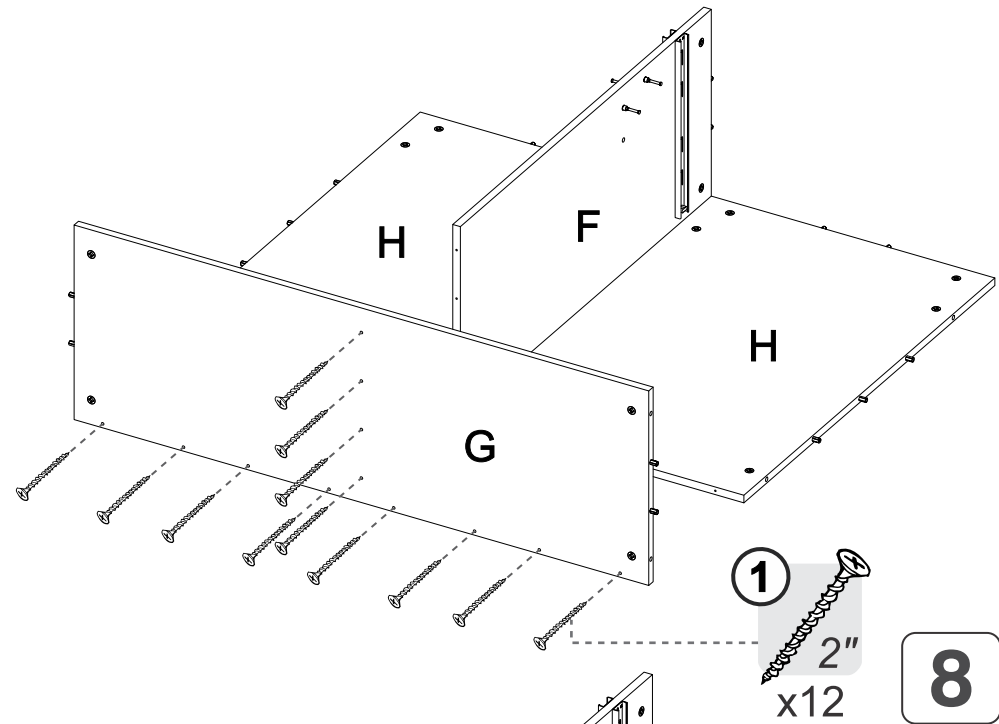

8

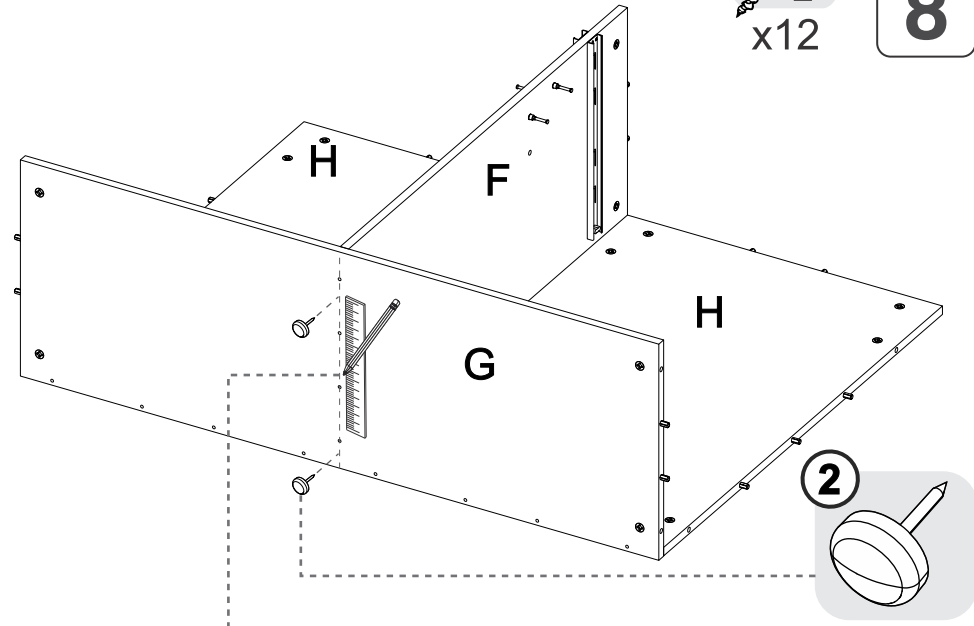

TRACE UNA LINEA ENTRE LAS PERFORACIONES CENTRALES PARA INSERTAR LOS DESLIZADORES / TRACE A LINE BETWEEN THE CENTRAL DRILLINGS TO INSTALL THE NAIL ON GLIDES

